



Llywodraeth Cymru  
Welsh Government

# Design Guidance

## Active Travel (Wales) Act 2013

December 2014





Llywodraeth Cymru  
Welsh Government

## Welsh Government Procedure & Advice Guidance (PAG) 102/14

Front cover photograph credit: Chandra Prasad / Sustrans



# Contents

Acknowledgements	4
Foreword	5
How to Use This Document	6
<b>Part A – General Principles</b>	<b>9</b>
<b>1</b> Introduction	10
<b>2</b> Legal and Policy Frameworks	15
<b>3</b> Involvement, Engagement and Consultation	23
<b>Part B – User Needs, Planning and Design</b>	<b>29</b>
<b>4</b> User Needs	30
Section 1 – Pedestrians’ Needs	32
Section 2 – Cyclists’ Needs	43
<b>5</b> Network Planning	62
Section 1 – Network Planning for Walking	69
Section 2 – Network Planning for Cycling	81
<b>6</b> Design for Walking and Cycling	103
<b>Part C – Related Matters</b>	<b>191</b>
<b>7</b> Integration with Other Modes	192
<b>8</b> Related Facilities	198
Section 1 – Related Facilities for Walking	198
Section 2 – Related Facilities for Cycling	208
<b>9</b> Creating, Improving and Managing Highways	227
<b>10</b> Construction, Maintenance and Management	241
<b>11</b> Monitoring and Evaluation	265
<b>Appendices</b>	
<b>A</b> Design Elements	273
<b>B</b> Walking Route Audit Tool	387
<b>C</b> Cycling Route Audit Tool	395
<b>D</b> Legal Procedures	407

# Acknowledgements

## Writing Team

The Wales Active Travel Design Guidance was produced by the following team on behalf of the Welsh Government:

- Roddy Beynon - Arup
- Kevin Golding-Williams – Living Streets
- Phil Jones (Editor) – Phil Jones Associates
- Andy Mayo – Local Transport Projects
- Tony Russell - Sustrans
- Chris Peck - CTC
- Carol Thomas – Access Design Solutions

Overseen by Jason Ingram (Welsh Government)

And with additional assistance from:

- Adrian Lord – Steer Davies Gleave
- John Parkin – University of the West of England
- Caroline Lewis – Access Design Solutions
- Jo Sachs-Eldridge – Local Transport Projects

Document design and layout by Phil Jones Associates  
(Annabel Keegan and Julie Price)

## Steering Group

In addition to the Writing Team, the Steering Group for the project comprised:

- Rhyan Berrigan – Disability Wales
- Simon Charles – Regional Transport Consortia
- Steve Davies – Newport City Council
- Robert Gravell – Cardiff Council
- Adrian Lord – Steer Davies Gleave
- Jane Lee – WLGA
- Andrea Gordon – Guide Dogs
- Jo Sachs-Eldridge – Local Transport Projects

## Support and Contributions

The Writing Team is grateful to the following people for their support and contributions to the project:

- Brian Deegan – Transport for London
- Wayne Duerden – Department for Transport
- Sally Gibbons – Department for Transport
- Ryland Jones – Sustrans
- Jane Lorimer – Sustrans
- Matthew Price – Cardiff Council
- Nick Vaughan – Transport for Greater Manchester
- Lee Waters – Institute of Welsh Affairs

And to Transport for London and Transport for Greater Manchester for the use of their design standard drawings.



# Foreword

Phil Jones, Phil Jones Associates

I was pleased to be asked in 2012 by Welsh Ministers to chair the steering group that oversaw the production of these guidelines; and subsequently to lead the expert writing team and act as the document's editor. I am now delighted to be asked to write this foreword on behalf of the Welsh Government.



In Wales, as in most developed countries, the increased use of the car for everyday journeys has brought substantial benefits to those people fortunate to have access to one. But it has also led to significant problems, including a growing level of obesity amongst children and adults; costly and distressing road accidents; increasing noise and emissions; and social exclusion for those who cannot afford to own a car.

We all know that change is needed, and we can see that it is beginning to happen across the UK and in many other places around the world. The Welsh Government is proud to be at the forefront of this new thinking through its ground-breaking Active Travel Act. For the first time, this legislation places a clear obligation on local authorities to provide transport systems that enable walking and cycling to be the first and natural choices when people need to make short everyday journeys.

This document sets out how local authorities should set about the task – sometimes for the first time – of planning and designing comprehensive networks of walking and cycling routes that connect places that people need to get to, whether for work, education, shopping or for other reasons.

It draws together best practice on infrastructure design, including innovative techniques, and gives guidance on how best to provide vital related facilities, such as cycle parking. It also explains how improving conditions for cycling and walking should be integrated into the general duties of authorities when planning, designing and maintaining highways. All of these elements will be essential if Wales is to achieve the First Minister's ambition of having the best cycling infrastructure in Europe.

The whole of my career has been spent working on planning and designing streets and roads and I know first-hand the challenges that have to be faced. But I also know the enthusiasm and passion of those who want to respond to and overcome them. I believe that this document provides practical guidance that will help bring about a substantial increase in active travel in Wales, and I wholeheartedly commend it to you.

Phil Jones

# How to Use This Document

This document is statutory guidance and is published by the Welsh Government under powers granted to Welsh Ministers under the Active Travel (Wales) Act 2013.

It is for everyone involved in the planning, design, approval, construction and maintenance of active travel routes in Wales. It will be of benefit to professional staff working for national government, local authorities and consultants as well as non-government organisations who help to create, modify and manage the built environment. These include private developers and other property owners, including health and education organisations.

It is also intended to be of use to the general public, who will need to be consulted on the maps and active travel schemes that result from the application of the Act. There is an important role for user groups in assessing whether the proposals made by local authorities meet the standards set out in this document.

The Guidance provides advice on the planning, design, construction and maintenance of active travel networks and infrastructure, and is to be used at all stages of the process. As noted in the Introduction, the Welsh Government intends to keep the document under review, so feedback on its application in all these stages, and how it can be improved, is welcomed.

This Design Guidance should be read in conjunction with the Delivery Guidance, also published by the Welsh Government, which sets out the processes relating to the preparation of the existing route maps and integrated network maps which are required by the Active Travel (Wales) Act.

There are three sections to this document, and a total of eleven Chapters and four Appendices.



## Part A – General Principles

This part gives general principles for the development of integrated networks and active travel routes.

- **Chapter 1** introduces the document
- **Chapter 2** provides a summary of the legal and policy frameworks in which it operates
- **Chapter 3** provides guidance on how to involve, engage and consult the public

## Part B – User Needs, Planning and Design

This part provides the main technical basis for the planning and design of active travel networks and schemes

- **Chapter 4** sets out the needs of people using the active travel network
- **Chapter 5** gives guidance on how active travel networks should be planned
- **Chapter 6** details the design of the elements making up the networks themselves

## Part C – Related Matters

This part provides technical guidance on other important issues

- **Chapter 7<sup>†</sup>** discusses how active travel networks should integrate with other modes of travel
- **Chapter 8** gives guidance on related facilities such as seating and cycle parking
- **Chapter 9<sup>†</sup>** explains how authorities should discharge their duties when creating and improving highways to benefit active travel
- **Chapter 10<sup>†</sup>** provides guidance on the construction, maintenance and management of active travel networks
- **Chapter 11<sup>†</sup>** advises how authorities should monitor and evaluate their networks

---

<sup>†</sup> Note – To the extent that Chapters 7, 9, 10 and 11 provide guidance falling outside the powers of the Welsh Ministers to issue guidance under the Active Travel (Wales) Act 2013, such guidance is non-statutory in nature. Nevertheless, such guidance is considered to represent good practice which will assist local authorities in their general duty to promote active travel under Section 10 of the Act.

## Appendices

There are four Appendices:

- **Appendix A, Design Elements (DEs)** – this provides a set of typical design details, with summary advice on their application. The DEs are given different status as explained in Chapter 1 and in the introduction to Appendix A.
- **Appendix B, Walking Route Audit Tool** – provides a useful tool for assessing the quality of walking routes
- **Appendix C, Cycling Route Audit Tool** – provides a useful numerical tool for assessing the quality of cycling routes
- **Appendix D Legal Procedures** – provides more detail on the common legal processes associated with the creation of active travel networks, including the carrying out of Equality Impact Assessments (EqIAs) under the Equality Act 2010.

It should be noted that although there is more technical content in this document relating to cycling than walking, this simply reflects the fact that there is less cycling infrastructure of a suitable quality already in existence, compared to walking. There is no implication that walking is to be given less priority than cycling – both are equally important active travel modes.

## Forthcoming Revision to Traffic Signs Regulations and General Directions (TSRGD)

Advice indicated with an asterisk (\*) anticipates the coming into force of the revised TSRGD, which is planned for March 2015. Until this document is published, special authorisation from Welsh Ministers will be required in order to comply with the guidance as written.



Llywodraeth Cymru  
Welsh Government

# Part A

## General Principles



# 1 Introduction

This Chapter explains:

- why the Welsh Government is promoting active travel
- how the Active Travel (Wales) Act 2013 will operate
- the purpose of this document in relation to the Act,
- its status and application; and
- how it will be kept up to date.

## 1.1. Active Travel in Wales

1.1.1 The Welsh Government seeks to enable more people to walk, cycle and generally travel by more active methods, so that:

- more people can experience the health benefits of active travel;
- we reduce our greenhouse gas emissions;
- we help address poverty and disadvantage, and;
- we help our economy to grow by unlocking sustainable economic growth.

1.1.2 One of the major steps in achieving these goals was the Active Travel (Wales) Act 2013 (hereafter referred to as the Active Travel Act) which gained Royal Assent on 4th November 2013. This created new duties for local authorities in Wales and the Welsh Ministers. It also gave the Welsh Ministers the power to issue guidance on the location, nature and condition of active travel routes and facilities to ensure they are suitable for use.

1.1.3 Research indicates that for many people, the biggest barrier to walking and cycling is concern for their safety. These concerns relate mainly to the existing infrastructure, such as difficult road junctions. The design of active travel infrastructure is critical in addressing safety concerns, both real and perceived, and is therefore key to achieving the aim of increasing active travel.

- 1.1.4 Where infrastructure already exists, breaks in the network and varying standards can affect people's ability to make use of it. The purpose of this document is to provide a consistent standard to work to when planning, designing, constructing and maintaining networks and routes for walking and cycling, and therefore achieve the step change that is needed.

## 1.2. Status of the Design Guidance

- 1.2.1 The Guidance is issued using the powers of the Welsh Ministers to give guidance under Sections 2(6), 2(9), 3(4), 4(5) and 7(2) of the Active Travel Act.
- 1.2.2 The document is published by the Welsh Government for use throughout Wales and the contents must be considered when designing and maintaining active travel routes and related facilities.

### Trunk Roads

- 1.2.3 The Welsh Government requires that the advice in this guidance **must be considered** when designing active travel routes on the trunk road. Currently all highway design on the trunk road network is undertaken in accordance with the Design Manual for Roads and Bridges (DMRB). The intention of this document is not to supersede any mandatory clauses within the DMRB, which remains as the prime guidance document for trunk road design. Manual for Streets (MfS) and Manual for Streets 2 (MfS2) (see below) are not appropriate for trunk roads.
- 1.2.4 Where designers consider that compliance with the advice contained within this design guidance will conflict with a mandatory clause in the DMRB, then this should be addressed through the Welsh Government's departures from standards process.
- 1.2.5 If, after consideration of the advice within this guidance, the trunk road designer elects to follow alternative guidance then they should retain documentation for this design decision.

### Non-Trunk Roads

- 1.2.6 For all non-trunk road networks this guidance **must be considered** by local authorities when designing active travel routes, even where the advice in this document conflicts with current local authority design standards. Local authorities may also consider guidance contained in MfS and MfS2, but advice contained in this document will take precedence if there is any conflict. If, after consideration of the advice within this guidance, the local authority elects to follow alternative guidance, then the local authority should retain documentation for this design decision.



1.2.7 This documentation will form the basis of the “explanation” required by section 3(6) of the Active Travel Act, which states:

When submitting an existing routes map to the Welsh Ministers under this section a local authority must also submit to them –

- a) a statement of the extent (if any) to which any of the active travel routes shown on it do not conform to standards specified in guidance given under section 2(6), and
- b) an explanation of why the local authority has nevertheless decided that it is appropriate for them to be regarded as active travel routes.

### 1.3. Innovation and Experimentation

1.3.1 The Active Travel Act opens up opportunities for the development and trial of more innovative infrastructure for walking and cycling, which will be essential if Wales is to achieve a step change in the amount of active travel. This guidance aims to support and encourage this by bringing together examples of well-established techniques, as well as more innovative designs being trialled in the UK, through the use of Design Elements with different statuses, as described below.

1.3.2 Moving forward, a number of ongoing developments will continue to drive new techniques, notably:

- Implementation of the Mayor’s Vision for London and investment in the English cities and towns receiving Cycle City Ambition Grant and other funding, which will involve rolling out a range of innovative measures to encourage cycling. These have been the subject of recent off-highway trials at the Transport Research Laboratory, including small and low level signals for cyclists, options for light segregation, bus stop bypasses and alternative roundabout designs, as well as signal junctions with two-stage right turns.
- The forthcoming major revision to the Traffic Sign Regulations and General Directions, due out in March 2015, that is expected to include a range of new design options for walking and cycling signs, road markings and associated infrastructure.

1.3.3 The Welsh Government will endeavour to update these guidelines in the light of these and other ongoing developments.

## 1.4. Design Elements

1.4.1 Appendix A to this Document consists of a set of ‘Design Elements’, which provide concise guidance, including dimensioned drawings where appropriate, on the layout and use of particular types of design solution.

1.4.2 In order to enable authorities to gain experience in the use of more innovative techniques, as well as being able to apply more well-established solutions with confidence, each Design Element has been given one of three statuses, defined as:



### Standard Details

Details that are well understood and should generally be applied as shown unless there are particular reasons for local variation.



### Suggested Details

Details that have not been widely applied in Wales but may be considered appropriate for use in the circumstances as advised.



### Possible Details

Details that are largely untested in Wales but have been used successfully in other places and may be considered for use in pilot schemes to gain further experience.

1.4.3 Within this document those elements denoted as Standard Details will be regarded as “standards” for the purposes of section 3(6)(a) of the Active Travel Act.

1.4.4 The use of advice categorised as Suggested Details or Possible Details will require careful monitoring by the highway authorities who implement them. More details of monitoring processes can be found in Chapter 11.

## 1.5. Other applications for the Design Guidance

1.5.1 The Active Travel Act requires the creation of an integrated network map, which will set out the local authority’s plans for active travel infrastructure for the next 15 years. Local authorities will have to have regard to the plans set out in the maps when developing their local transport plans. Chapter 5 will be of great use to local authorities in adequately planning their networks, in conjunction with Chapter 6 on the design of the routes themselves.



A

1.5.2 Local authorities are required to have regard to this guidance when creating or improving active travel routes. However this guidance will also be useful for planning active travel more widely. We encourage local authorities to use it for all their active travel and highway needs. Using the principles of the guidance will help provide safe and suitable infrastructure that is appropriate, thus avoiding over-engineering or wasting resources on facilities of little value.

## 1.6. Keeping Standards Up to Date

1.6.1 As noted above, the field of walking and cycling design guidance is evolving quickly. The intention is that this design guidance will be updated to take account of changes to design standards, new legislation or experience learnt from those implementing the design solutions contained within this document. This is expected to result in changes to the main guidance document and the status of some design elements, as experience is gained, together with the addition and/or deletion of others.

1.6.2 User views are essential for the successful evolution of this document and so all who use this guidance are encouraged to submit comments. These comments should be sent to the following address: [activetravel@wales.gsi.gov.uk](mailto:activetravel@wales.gsi.gov.uk)

## 2 Legal and Policy Frameworks

This chapter summarises the principal legislation and Welsh Government policy relating to the planning, design and implementation of active travel networks and routes.

Appendix D provides more detail on the common legal processes associated with the creation of walking and cycling measures, while Chapter 9 explains how authorities should discharge their duties under the Active Travel Act when creating, improving and managing highways.

### 2.1. Principal Legislation

#### **Active Travel (Wales) Act 2013**

2.1.1 The Active Travel Act makes provision -

- a) for approved maps of existing active travel routes and related facilities in a local authority's area,
- b) for approved integrated network maps of the new and improved active travel routes and related facilities needed to create integrated networks of active travel routes and related facilities in a local authority's area,
- c) requiring local authorities to have regard to integrated network maps in preparing transport policies and to ensure that there are new and improved active travel routes and related facilities,
- d) requiring the Welsh Ministers to report on active travel in Wales,
- e) requiring the Welsh Ministers and local authorities, in the performance of certain functions under the Highways Act 1980, to take reasonable steps to enhance the provision made for walkers and cyclists and to have regard to the needs of walkers and cyclists in the exercise of certain other functions, and
- f) requiring the Welsh Ministers and local authorities to exercise their functions under the Act so as to promote active travel journeys and secure new and improved active travel routes and related facilities.

2.1.2 For the purposes of this Act, a route in a local authority's area is an active travel route if it is situated in a designated locality, and the local authority considers that it is appropriate for it to be regarded as an active travel route.



- A
- 2.1.3 The designated localities within which active travel routes are to be planned and implemented are set out in the Designated Localities Direction of the Welsh Ministers.
  - 2.1.4 A “route” means a highway, or any other route to which the public has access (including a crossing), which may lawfully be used by walkers and/or cyclists without restriction. This can include permissive routes where the landowner’s consent has been given.
  - 2.1.5 Under the Active Travel Act “walkers and cyclists” means people who walk; people who use pedal cycles, other than pedal cycles which are motor vehicles for the purposes of the Road Traffic Act 1988; and disabled people not within the last two groups who use motorised wheelchairs, mobility scooters or other aids to mobility.
  - 2.1.6 When this document refers to routes for walkers and cyclists, or for active travel, this refers to routes that can be used by people who fit one or more of the descriptions above.
  - 2.1.7 In considering whether it is appropriate for a route to be regarded as an active travel route, a local authority must take into account whether the route facilitates the making by walkers and cyclists of active travel journeys, and whether the location, nature and condition of the route make it suitable for reasonably safe use by walkers and cyclists for the making of such journeys.
  - 2.1.8 In this Act “active travel journey” means a journey made to or from a workplace or educational establishment or in order to access health, leisure or other services or facilities.
  - 2.1.9 Local authorities must have regard to this guidance, which has been given by the Welsh Ministers under sections 2(6), 2(9), 3(4), 4(5) and 7(2) of the Active Travel Act, as to whether the location, nature and condition of the route make it suitable to be an active travel route.
  - 2.1.10 Under the Active Travel Act, the Welsh Ministers and each local authority must take reasonable steps to enhance the provision made for walkers and cyclists when they are exercising their functions under Parts III, IV, V, 1X and X11 of the **Highways Act 1980** (creation, maintenance and improvement of highways, interference with highways and acquisition etc. of land), as far as it is practicable to do so.
  - 2.1.11 The Highways Act 1980 includes provisions on the creation, maintenance and improvement of highways. Active travel routes will mostly be highways in law (a highway being essentially a route over which the



public has the right to pass and re-pass). This definition does exclude permissive routes, where the landowner’s consent to the use of the route would be required, but as noted above these may also be active travel routes.

2.1.12 Table 2.1 summarises the provisions of the Highways Act 1980 that are affected by the Active Travel Act.

**Table 2.1 - Powers and duties under the Highways Act 1980, as affected by the Active Travel Act**

Act	Part	Sections	Key powers and duties
Highways Act 1980	III – Creation of Highways	24 to 35	Power to create new highways, footpaths and bridleways
	IV – Power to adopt new public highways Maintenance of Highways	36 to 61	Duty to maintain highways  Power to adopt new public highways
	V – Improvement of Highways	62 to 105	Powers to generally improve highways, including constructing cycle tracks, traffic calming, refuges, bridges, subways etc.; duty to construct footways where necessary or desirable.  Power to prescribe improvement line for widening
	IX – Interference with Highways	130 to 185	Duty to protect the public’s right to use a highway, removal of obstructions, prevention of damage etc.  Duty to remove snow and soil etc.  Construction of vehicle crossovers



A

Act	Part	Sections	Key powers and duties
	XII – Land Acquisition	238 to 271	Powers to acquire land to construct public highways

2.1.13 Under the Active Travel Act, the Welsh Ministers and each local authority must also have regard to the needs of walkers and cyclists when they are exercising their functions under:

- a) Parts 1, II, IV and VII of the **Road Traffic Regulation Act 1984** (general and special traffic regulation, parking places and obstructions),
- b) Part 3 of the **New Roads and Street Works Act 1991** (street works), and
- c) Part 2 of the **Traffic Management Act 2004** (network management by local traffic authorities).

**Table 2.2 Powers and Duties under the: Road Traffic Regulation Act 1984, New Roads and Street Works Act 1991 and Traffic Management 2004, as affected by the Active Travel Act**

Act	Part	Sections	Key powers and duties
Road Traffic Regulation Act 1984	I – General Provisions for Traffic Regulation	1 to 5 and 9 to 11	<p>Powers to make orders to regulate traffic – prohibition, restriction or regulation use by any type of traffic.</p> <p>Powers to make experimental traffic orders</p>
	II – Traffic Regulation in Special Cases	14 to 22D	<p>Powers to make traffic regulation orders during construction works or for other special reasons.</p> <p>Powers to regulate traffic on byways in National Parks</p>



Act	Part	Sections	Key powers and duties
	IV – Parking Places	32 to 41, 45 to 49, 51 to 53 and 55 to 63A	Power to provide parking places for vehicles (of any class), both on and off street.  Power to acquire land to create parking places
New Roads and Street Works Act 1991	VII – Bollards and other Obstructions	92 to 93	Power to erect bollards etc. to prevent unlawful vehicular access
	3 – Street Works	48 to 106	Powers to control the placing and subsequent works to statutory undertakers' equipment, and the reinstatement of the highway.
Traffic Management Act 2004	2 – Network Management by Local Authorities	16 to 31	Duties in relation to network management by local authorities (which includes the road network used by pedestrians and cyclists).

- 2.1.14 Chapter 9 provides further guidance to local authorities on the discharge of the duties set out in Tables 2.1 and 2.2 when creating, improving and managing highways, whether or not they are active travel routes.
- 2.1.15 Under the Active Travel Act, local authorities are required to have regard to their integrated network map when forming local transport policies under section 108(1)(a) or (2A) of the **Transport Act 2000**, which requires local authorities to have local transport plans.
- 2.1.16 This duty was also modified by the **Transport Act 2006**, which requires local authorities to have regard to the Wales Transport Strategy when preparing their local transport plans. These plans must be approved by the Welsh Ministers, as do the Integrated Network Maps.

## **Equality Act 2010**

2.1.17 Section 149 of the **Equality Act 2010** introduced a general equality duty on the public sector. This is a duty to have due regard to three specified matters when exercising their functions. The three matters are:

- eliminating conduct that is prohibited by the Act
- advancing equality of opportunity between people who share a protected characteristic and people who do not share it; and
- fostering good relations between people who share a protected characteristic and people who do not share it.

2.1.18 In developing this guidance every effort has been made to consider the needs of people with protected characteristics throughout (see below for definition).

2.1.19 In applying this guidance, local authorities need to be satisfied that their activities comply with Equalities legislation. Equality Impact Assessments are valuable tools for demonstrating and monitoring the impact on those with protected characteristics.

## **Equality Impact Assessment (EqIA) Process**

2.1.20 The purpose of an EqIA is to identify any potential risks of unlawful discrimination and opportunities to promote equality and removing barriers to inclusion. They also support the outcome of delivering excellent customer service that meet the needs of, and are able to be accessed by all.

2.1.21 An EqIA is essentially a way of assessing outcomes to ensure that Initiatives do not discriminate against people on the basis of what are known as a protected characteristic:

- Age
- Disability
- Gender Re-assignment
- Marriage & Civil Partnership
- Pregnancy & Maternity
- Race
- Religion, Belief or Non-Belief
- Sex
- Sexual Orientation
- Welsh Language

2.1.22 Further guidance on the carrying out of EqIAs is given in Appendix D.

## 2.2. Principal National Policies

### Sustainable Development

2.2.1 Under the **Government of Wales Act 2006** the Welsh Ministers must make a sustainable development scheme setting out how they propose, in the exercise of their functions, to promote sustainable development. This scheme is set out in **One Wales: One Planet**. The Welsh Government's approach to tackling climate change is set out in the **Climate Change Strategy for Wales**, which includes a target to reduce greenhouse gas emissions by 3% a year. A greater use of active travel infrastructure can assist in meeting these objectives.

### Transport

2.2.2 The Welsh Government's transport policies are set out in **The Wales Transport Strategy**. This strategy document, required under the Transport Act 2006, sets out the full range of transport policies, including walking and cycling. It is supported by the National Transport Plan. Each Local Authority is required to have a Local Transport Plan under the Transport Act 2000, though there is provision to make these on a regional basis.

2.2.3 A more detailed summary of the Welsh Government's policies on active travel can be found within the **Active Travel White Paper**, published as part of the development of the Active Travel Bill.

2.2.4 The White Paper contains detailed information about the benefits of active travel. The **Active Travel Action Plan** sets out a range of activities that are being carried out to implement the Welsh Government's active travel policies. This is not just in the field of transport, but also health, leisure and education.

### Planning

2.2.5 **Planning Policy Wales** provides the policy framework for the effective preparation of local planning authorities' development plans. Chapter 8 relates to transport.

2.2.6 This is supplemented by topic based Technical Advice Notes (TANs). TAN 18 relates to transport and TAN 12 to design, including adopting inclusive design principles that deliver adequate provision for all people.

2.2.7 Procedural guidance is given in Welsh Office / National Assembly for Wales / Welsh Government circulars. Planning Policy Wales, the TANs

and the circulars may be material to decisions on individual planning applications. They will be considered by the Welsh Ministers and Planning Inspectors in the determination of called-in planning applications and appeals.

### Equalities

- 2.2.8 The **Strategic Equality Plan** is based on eight key Equality Objectives. This document sets out the Welsh Government's strategy for addressing inequalities in Wales, and draws on other areas such as the **Tackling Poverty Action Plan**, the **Framework for Independent Living** and the implementation of the **Rights of Children and Young Persons (Wales) Measure 2011**. Well designed active travel infrastructure can support these aims, by enabling better access for those with protected characteristics. The Disability Wales Guidance Toolkit **Planning for Inclusive Access** provides a practical resource to aid planning.

### Health

- 2.2.9 Physical inactivity is a recognised public health problem. Promoting active travel and providing suitable infrastructure can help meet local and national policies on promoting public health and reduce inequalities of health outcomes. The national strategy is set out in **Our Healthy Future**, supported by the Reducing Inequities in Health Strategic Action Plan, **Fairer Health Outcomes for All**.

### Education

- 2.2.10 Local Authorities have statutory duties relating to school transport. The **Learner Travel Measure (Wales) 2008** sets out that local authorities have a duty to risk assess routes to school, including walked routes.
- 2.2.11 In relation to carrying out risk assessments, local authorities in Wales were issued guidance to assess walked routes to school as part of the Learner Travel Statutory Provision and Operational Guidance published in 2014.
- 2.2.12 The guidance covers such issues as the need to consider the age and specific needs of learners; route conditions; traffic; footpaths; crossing points; canals; rivers; ditches; embankments; lighting; bridges and any other dangers, including social dangers. It also requires local authorities to take into consideration the views of children. The guidance has been drafted in line with the Rights of the Child Measure 2011.

# 3 Involvement, Engagement and Consultation

This Chapter provides general advice to local authorities on the principles of involving, engaging and consulting with the public and external organisations on the development of active travel networks and individual schemes.

## 3.1. Introduction

- 3.1.1 The Active Travel Act requires local authorities to consult on their existing route maps and integrated network maps, and makes the consultation one of the factors that the Welsh Ministers consider in deciding whether to approve the maps. Further guidance on the processes for consultation on the maps themselves can be found in the Delivery Guidance.
- 3.1.2 Consultation on the maps, however thorough, does not mean that the schemes or networks shown can be delivered without any further engagement with those affected. Particularly, it does not negate any statutory requirements for consultation and engagement that may be required as part of an individual scheme (for example, as part of a Compulsory Purchase Order or Traffic Regulation Order).
- 3.1.3 Consultation should result in better design and better schemes. As such, it is best carried out at several stages: from the development of the network to individual schemes. Good consultation at early stages can help to avoid poor decisions based on inaccurate or outdated information and gain greater community support for any new scheme. The more opportunity people have to influence and shape walking and cycling schemes for their local area, the more likely they will be to use them.
- 3.1.4 Broad consultation is also an opportunity to demonstrate more widely the local authority's investment in active travel provision and thereby their commitment to making active travel an attractive choice, which in itself can help increase the uptake.

## 3.2. Principles of Good Practice

3.2.1 The key to ensuring successful engagement on network planning and scheme design is that it meets the ABC requirements:

- Accessible – with regard to location, format, style, language, timing
- Broad – opportunity to get involved for everybody who is directly or indirectly affected, including potential users
- Clear parameters – clarity of scope and limitations of what is being discussed
- Suitable Tools – use of consultation and engagement tools

3.2.2 There are numerous resources available which provide more detailed advice on successful strategies and techniques for involving, engaging, and consulting with the public, in particular:

<http://www.goodpracticewales.com/Resources/Citizen-Engagement>

<http://www.involve.org.uk/>

3.2.3 The following guidance focuses on aspects of particular relevance to consulting on active travel networks and schemes.

### **Accessible**

3.2.4 Consultations on active travel networks and schemes must be accessible to all people regardless of their abilities and the extent of their knowledge or expertise. Officers undertaking consultation on behalf of local authorities need to be experienced in engaging diverse communities.

3.2.5 This will often require a range of media to be used - printed notices and online activity are not accessible for all groups and targeted engagement may well be necessary – for example using local radio, sessions with community groups such as access and disability groups, and culture groups where the main language is not English or Welsh. When engaging with children and young people their perspective and needs must be considered (see box out).

## Rights of Children and Young Persons

In exercising their functions under the Active Travel (Wales) Act 2013, local authorities are required to undertake all reasonable measures to ensure that children and young people are involved in the planning, implementation and review of decision-making processes. In doing so, local authorities can make use of existing mechanisms including local schools councils, youth councils and advocacy services.

All engagement with children and young people should be informed by the Children and Young People's National Participation Standards for Wales, published by Welsh Government.<sup>1</sup> This document stresses that children and young people's participation is an ongoing process rather than simply a series of one-off engagement events.

- 3.2.6 Authorities should avoid using unnecessary technical details and jargon when presenting information. Engineering-style drawings and scheme illustrations should be prepared in a way that does not assume any kind of engineering knowledge on behalf of those being consulted.
- 3.2.7 This can be achieved through the inclusion of maps which put the scheme into context, the avoidance of unnecessary technical information, the use of photos, sketches, and examples of similar schemes wherever possible. Where technical terms are necessary, an explanation must be included to ensure it is understood. Acronyms and abbreviations should be avoided if possible, or explained.

### **Broad**

- 3.2.8 Effective consultation at network and scheme level needs to target both current and potential users of walking and cycling infrastructure. This may include people using existing routes for leisure and sports purposes, including equestrians in rural areas.
- 3.2.9 Possible ways of reaching large numbers of people may be through major trip generators such as employers, schools, higher and further education institutions, hospitals, and also include local businesses, community and special interest groups.

<sup>1</sup> Available at: <http://wales.gov.uk/topics/educationandskills/publications/guidance/nat-standards-young-people-par?lang=en#>





3.2.10 Early engagement within the local authority itself, in particular those authorities where network planning and scheme delivery are separated, is also essential, as is engagement with elected members. Further guidance on the range of local authority departments and individual officers who can contribute to the successful development of active travel strategies, networks and routes is given in Chapter 5.

### **Clear Parameters**

3.2.11 It is important to set clear parameters for any contact with the public and other stakeholders, so that they understand clearly what can and cannot be changed as a result of their involvement, so that expectations are managed.

3.2.12 The nature and scope of the process should be clearly defined and this should include both its mechanisms, including time scale, and the expected output of the activity, including any decision processes that follow.

### **Suitable Tools**

3.2.13 There is a vast and constantly evolving range of consultation and engagement tools and methods, many of which would be suitable for consulting on active travel networks and schemes. These include:

- Community Street Audits
- Cycle Route Inspections
- Posters and site notices along routes
- Social media led events and online fora discussions, targeted at current or potential active travellers
- Events on radio and other local media

### Case Study – Cardiff Council’s consultation on the Enfys Network

As a sustainable travel city Cardiff is developing a number of schemes to bring sustainable transport options to Cardiff over the next decade or so. Local Transport Projects Limited (LTP) and Cardiff Council worked with ArkLab to consult with the public on the development of a draft strategy plan for cycling in Cardiff. They approached the project with two core goals

- Get as wide a response as possible to the plan that LTP would produce, and
- Raise general awareness of cycling within Cardiff.

ArkLab took over an empty shop on one of Cardiff’s busiest streets. They opened for two weekends with a late night Thursday, asking people what they thought of the plan and taking them through an interactive survey which allowed the public to engage with the strategy and give key insights on the plans.

As well as the shop the team designed an online survey which was a recreation of the interactive elements in the city centre consultation. They ran a mini marketing campaign both on and offline, involving local cyclist groups and offering free cycle maintenance workshops for the public.

The consultation achieved:

- Local media coverage
- Over 1,000 people visiting the online survey
- 50 vox-pop interviews
- Thousands of flyers handed out
- Theatre performance piece

<http://www.ark-lab.co.uk/project/cardiffcycling-cardiff-council-cycle-network-consultation>





Llywodraeth Cymru  
Welsh Government

## Part B

User Needs, Planning and Design



## 4 User Needs

This chapter sets out the basic needs of people when they make journeys on foot and by cycle.

### 4.1. Introduction

- B**
- 4.1.1 Walking and cycling as modes of transport have many similarities. They deliver significant physical and mental health benefits, reduce congestion, create no air pollution or noise, and are low cost forms of travel. The barriers to people taking up both modes share similarities such as fast traffic speeds and poor or lack of infrastructure. Reducing speeds, through measures such as the wider adoption of 20mph limits and other techniques (see Chapter 6) benefit both Active Travel Modes.
- 4.1.2 The needs of people walking and cycling can be summarised under the following headings, which are also reflected throughout the guidance. People wish to use routes that are:
- Coherent
  - Direct
  - Safe
  - Attractive
  - Comfortable
- 4.1.3 However, it is also important to note that they are distinct modes of transport with important differences. People on cycles and people on foot travel at different speeds and have different needs, which require different approaches to planning networks and designing infrastructure. In some circumstances pedestrians and cyclists can share the same space safely and effectively, and the design of such areas is discussed further in Chapter 6. However, most pedestrians and cyclists would prefer to have their own spaces so that both groups can travel at their own speed and without concerns over conflict.
- 4.1.4 Walking as a mode of travel predominates for journeys of less than two miles whilst cycling is more convenient for longer journeys, typically of up to five miles for regular journeys. Furthermore the current levels of utilisation of each mode are significantly different. Walking rates are relatively high, particularly for journeys of less than two miles, although there has been a long term decline in walking rates across most of Wales. Cycle use is coming from a very low base but take up is growing,

and the challenge is to increase and extend that rate of growth.

- 4.1.5 A key principle to be followed at all times is that improving conditions for cycling should not be bought at the expense of creating unacceptable conditions for pedestrians. Both active travel modes are important and local authorities should always aim to improve each of them.

## 4.2. Inclusive Design

- 4.2.1 With around 18% of the population of Wales aged over 65, and around 23% of the working-age population considered as disabled people, and with both figures increasing, it makes strategic long term sense to ensure our environments are accessible to the full range of types of people. Furthermore, a route that is accessible for disabled people will be more comfortable and convenient for all, such as older people and those accompanied by young children.
- 4.2.2 In the past the requirement for inclusive design has most commonly been applied to pedestrians, but similar considerations should also be applied to people using cycles, many of whom will have some form of disability. Disabled people may need to use inclusive cycles, such as tricycles, quadricycles or hand cycles, which require the careful design of facilities to make sure that their greater width and turning space requirements can be accommodated.

### Photo 4.1 – All-Ability Cycling



- B**
- 4.2.3 All public authorities have a duty under the Equality Act 2010 to ensure they meet the needs of disabled people, and actively involve disabled people in the design and delivery of their services such as the provision or improvement of pedestrian routes and cycle routes. An effective and timely Equality Impact Assessment can help ensure this, (see Chapter 2 for the legal framework for EqlAs). The requirement is to promote improvements rather than just guard against problems so as to enable inclusion and independence.
  - 4.2.4 It is important to recognise that disabled people are not a homogenous group and will have a range of requirements, and it is important that the full range of diversity is considered and accounted for when considering user needs - even two wheelchair users or two blind people may have different requirements.
  - 4.2.5 However, facilities which benefit one group of disabled people can also benefit another. For instance, logical and clearly defined pedestrian routes which follow accepted guidance for signing and wayfinding benefit a range of groups: Blind and partially sighted people will use recognised cues in the environment, such as tactile paving, buildings, kerb edges and controlled crossings for orientation and navigation; people with learning difficulties and autism benefit if routes are clear and not confusing, as would people who have mental health issues; deaf people and those with hearing impairments benefit through improved independence if they can follow a clear logical route without needing to ask for directions. It should also be noted that one of the causes of vision impairment, diabetes, also causes reduced sensitivity in people's feet so that they may have difficulty feeling the surfaces they are walking on.
  - 4.2.6 Environments which accommodate the needs of disabled people will also be helpful to able-bodied people who are temporarily encumbered in some way – for example by carrying heavy shopping or by looking after a young child in a pushchair – or people who have particular concerns over personal safety.

## Pedestrians' Needs

- 4.2.7 The principal needs of pedestrians have been summarised under the 5 key principles for active travel routes, as introduced in Section 4.1.
- 4.2.8 Research carried out by Living Streets (Table 4.1, p. 34) also reveals pedestrians' day to day concerns.



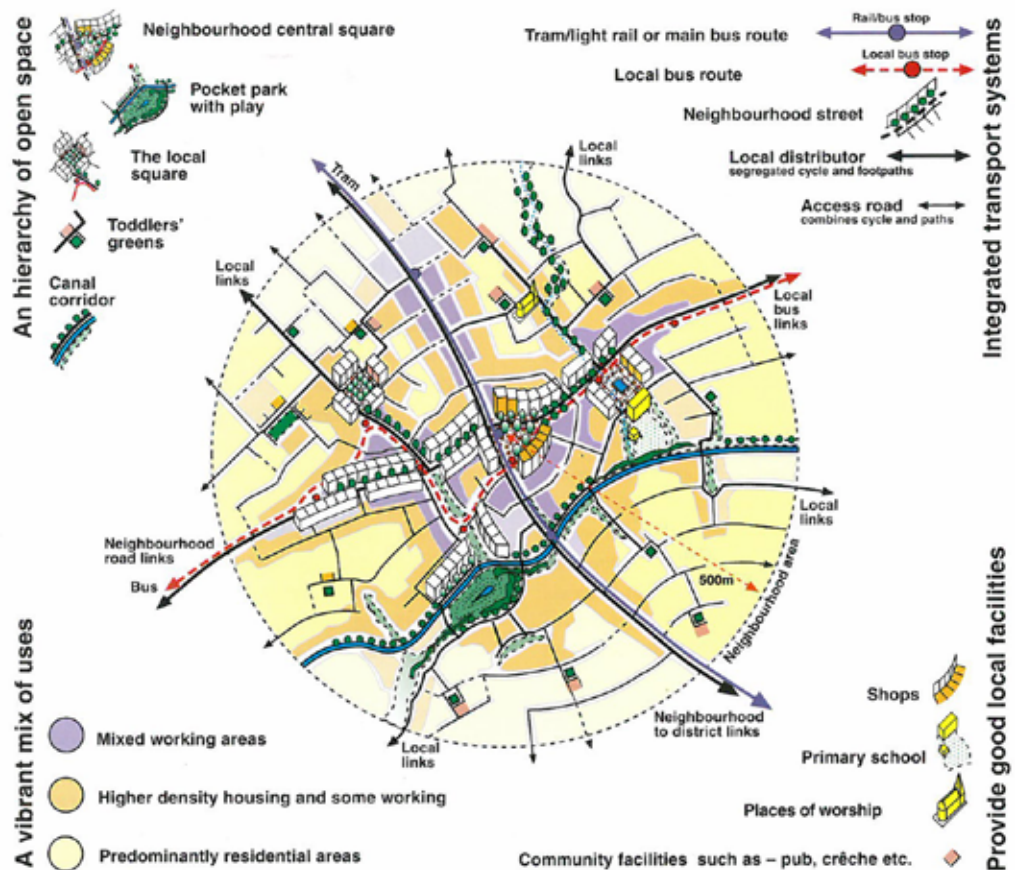


### 4.3. Coherent

- 4.3.1 Pedestrian routes must allow people to reach their day to day destinations easily and logically. Important places to be served by walking networks include homes, shops, schools, transport interchanges and bus stops and other community facilities. Better accessibility to public transport is likely to encourage its use and decrease reliance on the private car for longer journeys.
- 4.3.2 Manual for Streets advises that walkable neighbourhoods, as illustrated in Figure 4.1 below, are characterised by having a range of facilities within 10 minutes' walking distance (about 800m) which people may access comfortably on foot, although it is important to note that this depends on walking speed and will be less for older and disabled people. Therefore, the creation of mixed-use neighbourhoods with interconnected street patterns, where daily needs are within walking distance of most residents will tend to lead to more walking.



**Figure 4.1 – Walkable neighbourhoods, Report of the Urban Task Force, 1999**



### Challenges Facing Pedestrians

Pedestrians' common concerns can be judged from research, undertaken for Living Streets in 2012, which asked Welsh adults which, if any, of the following problems they had encountered on their local streets.

**Table 4.1 – Challenges facing pedestrians – YouGov poll for Living Streets**

Problem	Percentage (%)
Litter or dog fouling	76
Broken or cracked pavements	66
People parking on the pavement	62
Potholes in pavements	58
Pavements which have been badly patched up after street works	54
People cycling on the pavement	53
Fly tipping, graffiti or abandoned cars	41
Street clutter and obstructions on the pavement	39
Badly managed street works	32
Street lighting not working/not enough street lighting or street lighting being turned off or removed	23

- 4.3.3 Pedestrian routes should connect with one another seamlessly to form a comprehensive, permeable and logical network. Routes must be legible i.e. clearly defined and identifiable by all. High quality, well placed and, where appropriate, tactile embossed/Braille signs are vital to ensure pedestrians are sufficiently aware of the most direct route to local facilities (See Chapter 10). Layouts of walking routes should be simple, logical and consistent. This will enable people to memorise environments that they use regularly and predict and interpret environments that they are encountering for the first time.

4.3.4 Any severance of key pedestrian routes by busy roads or other obstacles such as railways, waterways and sharp changes in level must be reduced or overcome through appropriate and sympathetic schemes. Surface level crossings of roads coupled with other design measures such as reducing traffic speeds can help. Diverting pedestrians through subways and across footbridges should be minimised due to the potential accessibility problems for older people and people with disabilities. Subways can also deter walking through perceptions (real or perceived) of crime and personal safety and add to the time and distance of a journey.

#### 4.4. Direct

4.4.1 Pedestrians are moving under their own efforts and therefore require routes and networks which are direct and follow natural desire lines.

4.4.2 Many new housing developments have convoluted and impermeable layouts, often driven by a desire to control motor traffic speeds. That is understandable, but a balance needs to be struck between calming traffic and creating a layout that gives direct routes to people on foot. Pedestrian-only routes between culs-de-sac are essential to provide permeability but careful design is needed to ensure that these do not become places where anti-social behaviour and crime can flourish.

4.4.3 At a detailed level, as noted in Manual for Streets, pedestrian routes should be as straight as possible through road junctions. Tight corner radii are preferred which minimise the need for pedestrians to deviate from their desire lines when crossing minor roads. Crossing on a radius is hazardous for blind and partially sighted pedestrians as it is very difficult to orientate in a straight line from a radius and the person can inadvertently wander into the open road.

#### 4.5. Safe

4.5.1 Safety (both actual and perceived) is an essential user need for pedestrians, both in the form of preventing physical harm through collisions with vehicles and minimising threats to personal safety.

4.5.2 Good road safety is achieved by separating pedestrian routes from fast vehicle routes in space and/or time; and/or by reducing vehicle speeds and flows to a level such that risks are brought to an acceptable level.

4.5.3 Fears over personal safety can be a major barrier to walking. Street lighting is an important influence on the public's perception of what constitutes a safe street and local authorities should ensure streets and

paths are well lit at times they are likely to be well-used, with an even and continuous distribution of lighting, avoiding glare and pools of light and shadows. Street lighting should provide an attractive street environment which provides reassurance for pedestrians and any faults should be repaired quickly.

- 4.5.4 Pedestrian routes should be overlooked by buildings which are inhabited and well used by pedestrians and environmental anti-social activity such as graffiti, litter or vandalism should be reduced to a minimum or removed or repaired quickly. Pedestrian routes should have clear exit and entrance points where people cannot be trapped, such as subway networks and blind corners. Overhanging shrubbery should be reduced to improve sight lines and to prevent it becoming an obstruction for blind and partially sighted people. It is also important that Highway Authorities work with other partners such as the Police to ensure pedestrians feel safe using walking routes through initiatives such as regular community policing.

## 4.6. Attractive

- 4.6.1 Attractive pedestrian routes not only encourage more people to walk but also contribute to the overall quality of an area and can help to create a sense of place through the creation of more accessible public spaces.
- 4.6.2 As Manual for Streets usefully remarks 'The propensity to walk is influenced not only by distance, but also by the quality of the walking experience. A 20-minute walk alongside a busy highway can seem endless, yet in a rich and stimulating street, such as in a town centre, it can pass without noticing. Residential areas can offer a pleasant walking experience if good quality landscaping, gardens or interesting architecture are present' (MfS, Para 6.3.1).
- 4.6.3 Pedestrian routes can deliver both a place and movement function although the balance between such functions may depend on external influences such as the time of day or day of the week. A pedestrian route may deliver a movement function during the working week and revert to more of a place function during the weekend, for example by being used for a street market.
- 4.6.4 Manual for Streets considers the role of place in detail but in essence place function is about how people gain from an area, even when they are not moving. The availability of spaces to rest and reflect, and paths for relaxing walks, are important for mental health and wellbeing. Some quiet spaces and walks, such as areas of local parks, should therefore be included within the network of pedestrian routes where they form part of active travel routes.



4.6.5 As well as encouraging active travel, attractive streets and public realm deliver increased economic activity through increases in footfall and rateable values of high streets (Living Streets, 2013). Creating attractive pedestrian routes requires targeted reduction of street clutter, use of community led design techniques, regular street cleansing and the regular maintenance of street furniture and footway surfaces.

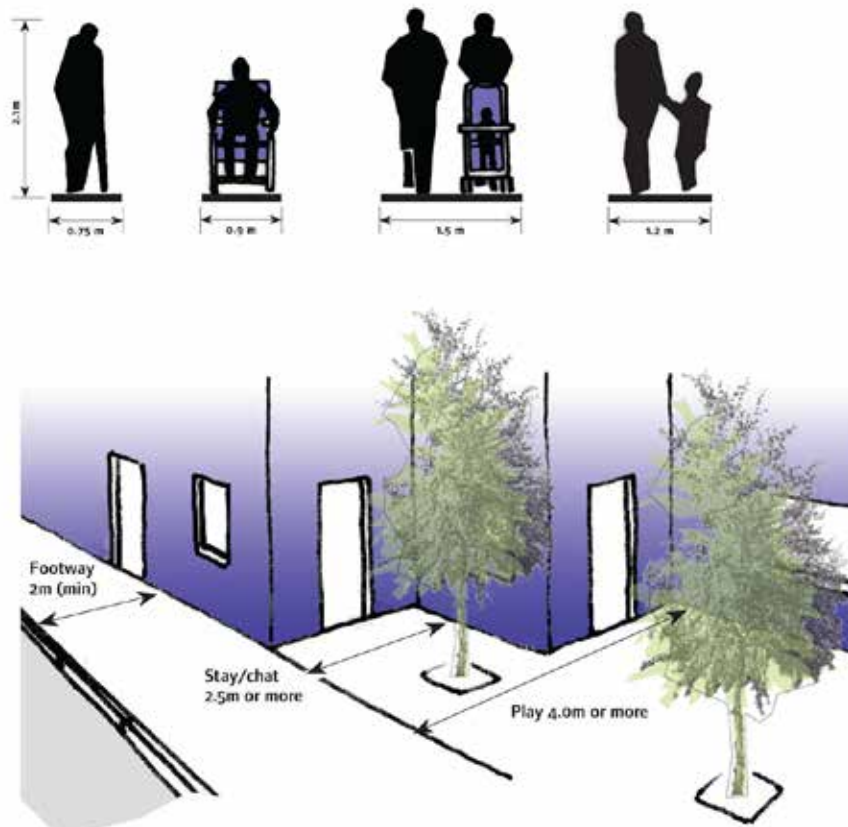
## 4.7. Comfortable

4.7.1 Pedestrian comfort is influenced by a range of factors including the basic design of the route – its width as related to the number of users and the gradient and quality of the surface – as well as other elements such as tactile paving, street furniture, drainage, cleanliness and lighting.

### Widths

4.7.2 Basic width requirements for different types of people walking or using mobility aids are given in Inclusive Mobility and Manual for Streets which is the source for Figure 4.2 below.

**Figure 4.2 – Width requirements of different types of user and recommended footway widths from Manual for Streets**



- B**
- 4.7.3 Where possible, pedestrian routes should have a clear unobstructed width of 2m, which allows two wheelchair users to pass one other. Where physical constraints make this impossible a clear width of 1.5m should be maintained as this allows a wheelchair user and walking companion to travel side by side. If there is an obstacle that cannot be moved a restricted width around this of 1.2m provides space for a blind or partially sighted person to walk using a long cane, or with a guide dog, or alongside a person providing guidance.
- 4.7.4 Some routes will require greater width than the minimum given above due to the number of pedestrians that habitually use the route and/or the main category of user. A suitable footway width is important to allow pedestrians to travel comfortably at their chosen speed and in groups, such as when walking with younger children. For example, the areas around schools will be used by large numbers of children and young people at the start and end of the school day. Hospitals will generate large numbers of movements of people with a range of physical, sensory or cognitive impairments and a range of mobility needs.
- 4.7.5 Further detail on the assessment of pedestrian capacity is given in Transport for London's Pedestrian Comfort Guidance for London (2010) see Figure 4.3. It defines Levels of Service for pedestrian capacity in terms of pedestrians per minute per metre width (ppmm) and defines area types with peak pedestrian times including high street, office and retail, residential, tourist attractions and transport interchanges. **Generally a minimum Level of Service B (no more than 11 pedestrians per minute per metre width at peak times) should be achieved on all active travel routes.**
- 4.7.6 Unnecessary and badly placed street furniture, which can include pole-mounted signs, utility boxes, phone boxes, litter bins, A-boards, bollards and guard railing, reduces the available width of footways and is a particular hazard for visually impaired people. While some items of street furniture are important, unnecessary and badly-placed items will have a detrimental effect on pedestrians. Low obstacles of less than 60cm in height can be a trip hazard and are particularly difficult for visually impaired people to detect. The amount of street furniture should be minimised with remaining items located in a street furniture zone out of the pedestrian flow.



Figure 4.3 - Extract from Pedestrian Comfort Guidance for London



- B**
- 4.7.7 Highway Authorities should take action to prevent the obstruction of pedestrian routes by thoughtless behaviour. In particular, the use by retailers of advertising A-boards should be prevented or at least controlled. These unregulated advertisements can add significantly to street clutter and pose a risk to older people and those with visual impairments who may use the building line to navigate their walking journey.
- 4.7.8 Footway parking causes hazards and inconvenience to pedestrians. It can block routes for wheelchair users, older people and parents with children and can be particularly hazardous for blind and partially sighted people who risk bumping into wing mirrors or even open car boots. It can also pose a road safety risk to all road users, especially blind and partially sighted people, by blocking the view of the road and forcing pedestrians into the path of traffic in order to continue their journey.

### **Gradient**

- 4.7.9 Steep gradients can have particular impact on older people, those with physical disabilities and parents with pushchairs.
- 1% (1 in 100) - is never an obstacle.
  - 2% (1 in 50) - can be managed by most people (and also provides good drainage).
  - 2.5% (1 in 40) - can be managed by many people.
  - Steeper than 2.5% - impossible for many manual wheelchair users.
- 4.7.10 Steeper gradients than these can be managed by some wheelchair users, but only over very short distances (1m or less), for example on a ramp between a bus entrance and the pavement. Even over these short distances the maximum gradient used should be no more than 10% (1 in 10).
- 4.7.11 As a general rule, a gradient of 5% (1 in 20) should be regarded as a desirable maximum in most situations and 8% (1 in 12) should be used as the absolute maximum. However, it is recognised that there will be locations where steeper gradients cannot reasonably be avoided. In these situations local authorities will need to explain the justification for proposing steeper gradients, as per the requirements of Section 3(6) of the Active Travel Act.



- 4.7.12 Steep cambers and crossfalls are a problem for many people, including wheelchair users. Crossfalls should preferably be 2.5% (1 in 40) with a desirable maximum value of 3.3% (1 in 30) and an absolute maximum of 10% at crossings.
- 4.7.13 The choice of surface materials on walking routes is important to pedestrian comfort, and can also contribute to the character of a street environment. In general, surfaces should be even, firm and slip resistant in wet and dry conditions. The maximum deviation under a 1m straight edge should not exceed 6mm.
- 4.7.14 Contrast is important to many visually impaired people, many of whom are able to distinguish changes in colour and tone. Footway materials should therefore be consistent, avoiding the use of random patterns which have no meaning. Good contrast between pedestrian routes, cycle tracks and carriageways will help visually impaired people to make sense of their environment.
- 4.7.15 When paving flags or block paving are used, care should be taken to ensure that they are evenly laid; any unevenness can cause problems for some wheelchair users and some visually impaired cane users. Cobblestones should not be used unless they are flat, smooth and constructed within level tolerance.
- 4.7.16 The provision of areas and benches for pedestrians to rest and sit is a particularly important user need for older pedestrians and those with physical disabilities (see Chapter 8). The provision of clean and accessible public toilets is also an important user need particularly for older people or those with children.



## Key References

Department for Transport (2013) Code of Practice - street works and road works, London

Department for Transport (2007) Manual for Streets, London

Department for Transport (2007) Guidance on the use of Tactile Paving Surfaces

Department for Transport (2005) Inclusive Mobility: London

British Standards Institution (2009/2010) - BS 8300:2009+A1:2010 Design of buildings and their approaches to meet the needs of disabled people. Code of practice.

Chartered Institution of Highways and Transportation (2000) Guidelines for providing for journeys on foot, London

Living Streets (2013) The pedestrian pound - the business case for better streets and places, London

National Federation of the Blind of the UK (2013) Access For Blind People In Towns. SS1401

Transport for London (2010) Pedestrian Comfort Guidance for London

## Cyclists' Needs

### 4.8. Introduction

- 4.8.1 In the Active Travel Act, a cyclist is simply defined as someone who uses a cycle, and so in this document, 'cyclist' is used a shorthand for anyone who happens to use a cycle, whatever the distance, speed or purpose of the journey, or the characteristics of the person.
- 4.8.2 Designs should therefore meet the needs of everyone who cycles for any reason and at any age or physical condition; as well as those who are considering taking up cycling for the first time particularly children and young people. Cycle routes should cater for a wide spectrum of people with different levels of confidence and experience; including people riding cycles adapted to meet particular physical needs (see Section 4.2 above).

### 4.9. Why do people cycle?

- 4.9.1 The principal reasons given for cycling are that it is convenient and fast. In addition, many users are motivated by the health benefits they get from cycling (Cycling Embassy of Denmark, 2012). However, reasons can differ depending on age of user or trip types, or even time of day.
- 4.9.2 The most significant barrier to achieving more cycling is the perceived lack of safety, particularly for women and older people, who are under-represented amongst regular cyclists in the UK<sup>2</sup>.
- 4.9.3 While main roads are often the most direct, coherent network available to cyclists, they are the places where fear of and intimidation by motor vehicles is at its greatest. Consequently, in many areas the provision of adequately safe, attractive and comfortable facilities along these roads is crucial to encouraging active travel. These routes can be supplemented by more indirect routes along minor roads or paths.

<sup>2</sup> Understanding Walking and Cycling – Lancaster University, 2011; Attitudes towards cycling, Annual Report 2012 – Transport for London

## Cycling Safety

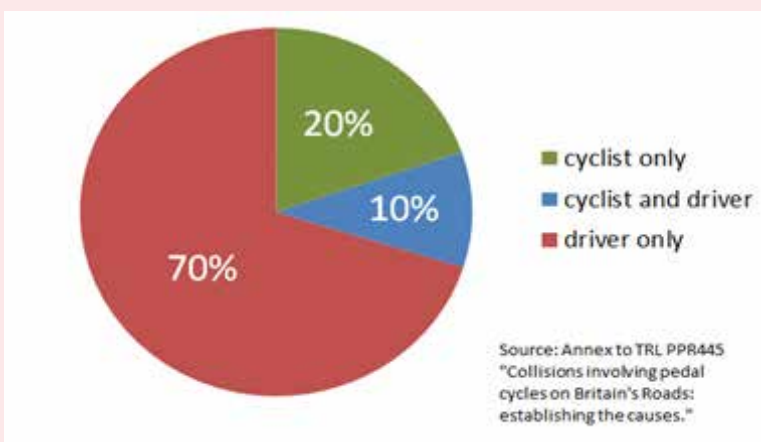
The health benefits of cycling greatly outweigh the risks of injury encountered while cycling, however, the risks of injury while cycling are typically higher than when travelling by car. Per mile travelled, the fatality risk of cycling is comparable to walking, with around 31 pedestrians killed per billion kms walked and 27 cyclists killed per billion kms cycled (DfT, 2013d).

There are approximately 80,000 cycle casualties per year in Great Britain of which proportionately around 1,250 occur in Wales (DfT, 2013c). Of these casualties just over a third are reported to the Police, nearly all of which involved another vehicle or pedestrian.

Most of the large number of non-reported collisions are cycle-only incidents, many of which involve ice, wet or oily surfaces, gravel, debris or mud. This shows that attention must be paid to maintaining smooth, textured surfaces that are swept and receive good winter maintenance.

Collisions involving motor vehicles tend to be serious, representing over 90% of fatalities. Most of these collisions are considered by Police to be the fault of the driver, (see graphic below).

### Collisions involving cyclists aged >25 and drivers - contributory factors attributed by police (2005-07)





Over two thirds of collisions with vehicles occur at junctions (DfT 2013b). A quarter of all serious injuries or deaths to cyclists involve motor vehicles turning either left or right, with the remainder either involving overtaking, or where the vehicle is moving ahead (TRL, 2009). Heavy goods vehicles are disproportionately involved in cycle fatalities: 18% of deaths involve these vehicles, despite them making up just 5% of road traffic.

It is therefore vital to provide safe, coherent, direct and comfortable routes for cyclists through major junctions - otherwise even high quality links will be underused by cyclists who are unable to interact with fast moving traffic; particularly people who are nervous, inexperienced, elderly or who have disabilities.



#### 4.10. The Effort Required to Cycle

- 4.10.1 The amount of effort required to cycle depends on physical conditions and the local environment: on surface quality, surface material, ability to maintain constant speed, gradients, deflections and undulations and prevailing winds.
- 4.10.2 The conservation of cyclist effort should be a key consideration in the design of any cycling facility. Designers can take positive steps to enable people to cycle with the minimum of effort:

**Table 4.2 – Factors Affecting Cycling Effort**

Factors affecting cycling effort required		Meaning	Design implications
The Cycle and Rider	Speed travelled	A cyclist’s ability to maintain their own speed matters a great deal.	Routes that are direct and allow cyclists to maintain their speed are the most appealing to users – designers should avoid making cyclists stop, slow down, or deviate unnecessarily from their route.
	Efficiency of cycle	All these factors, taken together, means that stopping and starting require a lot of effort; much more than maintaining a constant speed.	
	Mass of rider and cycle		

**Table 4.2 – Factors Affecting Cycling Effort**

Factors affecting cycling effort required		Meaning	Design implications
		It also means that lighter cycles require less effort to ride and that it is a good idea to maintain a cycle in optimum working order.	The effective width available for cycling and the choice of junction type are important factors in allowing for maintenance of speed.
Surface quality	Resistance of the road surface	The greater the surface resistance, the harder it is to cycle. This is particularly true for small-wheeled cycles.	The quality and smoothness of the riding surface, and its continued maintenance, are essential for comfort and efficiency.
Gradient	Gradient	The steeper the gradient, the more energy is required to overcome it.	Directness of route may need to be balanced with avoiding steep gradients.
Air Resistance	Headwind Frontal area and drag coefficient	The frontal area of the cyclist matters: upright cyclists using 'city bikes' have to generate more power.  Importantly, environmental conditions also matter. Cycling into a prevailing headwind, requires much more effort. Local conditions, such as microclimate around tall buildings, can exacerbate this.	Designing to reduce headwind effects has not been commonplace in Wales but can make a big difference. Windbreaks using planting, trees or fences, can help mitigate the effects of strong winds

B



### Electrically Assisted Pedal Cycles

- 4.10.3 Electrically-assisted pedal cycles are in widespread use in continental Europe and are becoming increasingly popular in the UK. They provide power to drive the wheels in addition to the effort of the cyclist, up to a speed of 15mph, and make it much easier to tackle hills. They therefore have great potential for use in Wales. In design terms, they are little different to conventional cycles, and can use cycle lanes, tracks and parking spaces in the same way.

## 4.11. The Dimensions of Cycles and Cyclists

- 4.11.1 Typical conventional cycles for adults are around 1.8m in length and 0.65m in width. For an adult cyclist, 0.8m is the typical static width but extra width is needed for moving cyclists (see below). A reasonable assumption is that this amounts to a total width of 1m (as stated in LTN 2/08) – this is referred to as the ‘dynamic envelope’
- 4.11.2 People using non-standard types of cycles should not be excluded from using cycle infrastructure through lack of consideration for their needs at the design stage. There are many types of non-standard cycles, including:
- Cycles with trailers for children or deliveries
  - Tricycles
  - Tandems with two or more seats
  - Inclusive cycles designed for disabled people e.g. quadricycles and hand cycles
  - Recumbent cycles
  - Cargo bikes (for carrying goods or children)
  - Small-wheeled foldable cycles
- 4.11.3 Inclusive cycles are those that are suitable for people with disabilities to use, and can be tricycles (both upright and recumbent), handcycles, tandems or solo bikes adapted to suit the rider’s disability. Although the dimensions of these cycles varies, a ‘Standard Inclusive Cycle’ has been defined which is an abstract composite of all the cycles that might reasonably use the cycle network. It includes the solo cycle, tandem, cycle + trailer, cycle + trailer bike, tricycle (upright and recumbent), hand-cycle, cargo-bike, cargo-trike, wheelchair and the mobility scooter. Designing the cycle network around this design model ensures that it is accessible to all.

**Table 4.3 – Cycle Dimensions and Turning Circles**

Type of cycle	Typical length (mm)	Typical width (mm)	Minimum turning circle (mm)	
			Outer radius	Inner radius
Conventional cycle	1,800	650	1,650	850
Cycle with 850 wide trailer	2,700	850	2,650	1,500
Tandem	2,400	650	3,150	2,250
Standard Inclusive Cycle	2700 (max)	1200 (max)	3,400 (max)	100 (min)

Note – based partly on LTN 2/08

- 4.11.4 It is unusual for the dynamic envelope of any cycle to be any greater than 1.4m, and consequently, any one-way cycle lane or track should be at least 1.5m wide, or it will risk excluding some types of user. The use of chicanes or gates aimed at restricting unauthorised access to paths (e.g. by motorcycles) may also obstruct these users, and therefore must not be used unless in exceptional circumstances. Further advice on access controls is given in Chapter 6.
- 4.11.5 Turning circles are an important consideration, both in terms of the space required to execute a full turn, which LTN2/08 calls the ‘outer radius’, and the space required to turn around a fixed object, or ‘inner radius’. For conventional cycles, the inner radius should be at least 0.85m and outer radius 1.65m, although these will require the cyclist to be travelling very slowly, and larger radii are appropriate at higher design speeds. The turning radii of non-standard cycles may be considerably larger than that of standard ones.
- 4.11.6 Table 4.3 above (adapted from LTN 2/08) summarises the key dimensions and minimum turning circles of different types of cycle.



- 4.11.7 Minimum corner radii for cycles travelling at various speeds exceed the minimum values in Table 4.3 and are given in Table 4.5.

## 4.12. Headroom

- 4.12.1 Cyclists require a minimum of 2.7m of headroom. This may be reduced to 2.4m where the obstruction is for less than 23m (such as where a traffic sign spans the carriageway) (Highways Agency, 2005b) or 2.3m at instantaneous obstructions such as signs.
- 4.12.2 Every effort should be made to provide this headroom; where this cannot be achieved (i.e. at a low railway bridge), 'limited headroom' signing should be provided in a similar fashion as for a low bridge over a carriageway (see Traffic Signs Manual, Chapter 4, Section 7 (TSO 2013), in preference to 'Cyclists Dismount' signs, the use of which should be avoided on active travel routes.

## 4.13. Cycling Speeds

- 4.13.1 The speed of different people on cycles can vary widely – ranging from walking pace (for children or people using cycles adapted for users with disabilities), up to 25mph or more on steep, downhill gradients. This presents a challenge for those trying to plan to accommodate the variety of cyclists' needs.

**Table 4.4 – Typical desired speeds and proportion of trips, by cycle user type**

User type	Typical desired speeds	Current approximate share of cycling trips
School travel	5-15mph	10%
Leisure	5-15mph	36%
Adult shopping or other	10-15mph	15%
Adult commuting	10-20mph	39%

Note: Based on "Design speeds and acceleration characteristics of cycle traffic for use in planning, design and appraisal", by Prof John Parkin and Jonathon Rotheram, and the National Travel Survey.

- 4.13.2 Although speeds do vary, the aim should always be to create facilities that suit as wide a range of people as possible, rather than setting out to provide 'dual networks' for novice and experienced cyclists. This can be done by creating facilities that enable people to travel at the speed they wish to, with sufficient space to overtake.
- 4.13.3 Most cyclists will wish to travel between around 12mph (20km/h) and 18mph (30km/h). Based on these speeds, plus a lower design speed of 6mph (10km/h), the key geometric criteria shown in Table 4.4 are recommended.

**Table 4.5 – Minimum Forward Visibility, Horizontal and Vertical Curvature**

Parameter		Design Speed		
		18 mph/ 30km/h	12 mph/ 20km/h	6 mph/ 10km/h
Minimum Forward visibility	Desirable	80m	50m	30m
	Preferred	30m	30m	30m
	Absolute	25m	15m	10m
Minimum Horizontal Curvature, Inner Radius	Absolute	25m	15m	4m
Vertical Curvature, Crest K Value	Desirable		5.0	
	Preferred		1.6	

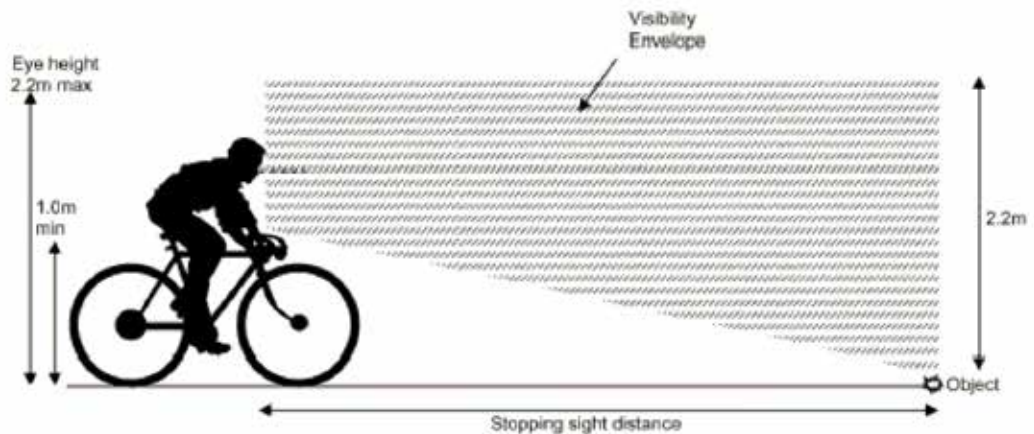
**Note:** Based on Cardiff Cycle Design Guide



4.13.4 Visibility should be available over the following envelope, as shown on Figure 4.4 below:

- Eye height in the range of 1.0m to 2.2m to accommodate the wide variety in cyclists' riding positions
- Ground level, so as to observe any surface defects in good time
- Objects at a height of 2.2m, so any low obstacles can be seen in good time

**Figure 4.4 – Cyclists' visibility envelope – reproduced from DMRB TA90/05**

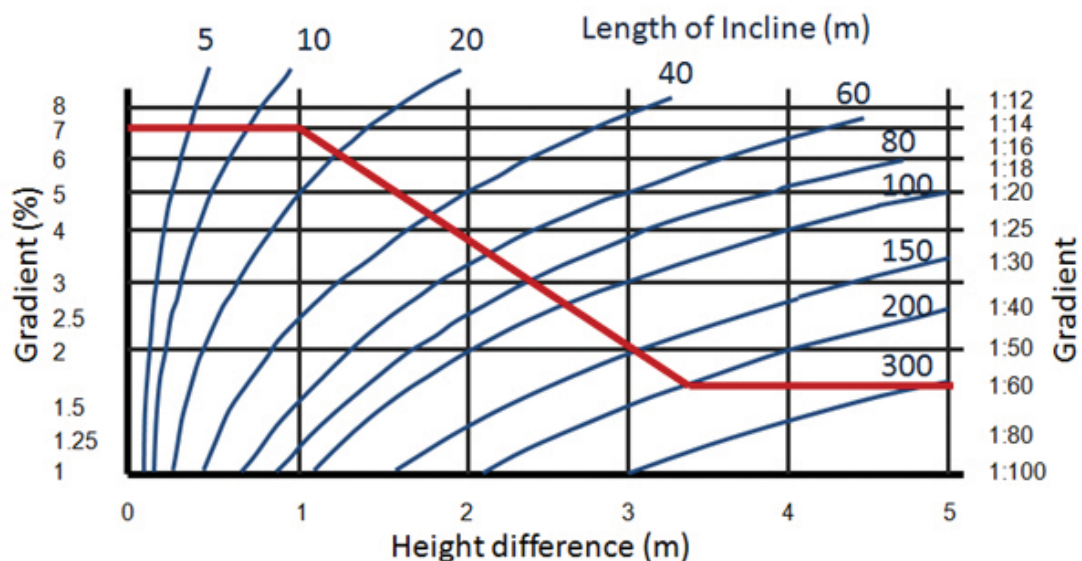


#### 4.14. Gradients

- 4.14.1 Sections of rising or falling route create specific challenges for cyclists. Ascending even short uphill gradients considerably increases the discomfort for cyclists. It is particularly difficult for less able cyclists, such as older people, those with impairments or people using adapted cycles, which tend to be heavier and offer limited ability for short-term increases in power. Downhill gradients can lead to rapid increase in speed, which increases the risk of loss of control.
- 4.14.2 Where possible, routes should avoid the steepest gradients. The priority for improvement to routes should be focused on routes with least ascent or descent.
- 4.14.3 The maximum desirable gradient depends on length. People are better able to tackle short steep gradients, but even relatively gentle gradients can become difficult if they are sustained.

- 4.14.4 Figure 4.5, adapted from the Design Manual for Bicycle Traffic (CROW, Netherlands), shows the relationship between desirable maximum gradient and the length of the incline, with the red line on the chart showing the desirable maximum values.
- 4.14.5 For example, with a length of incline of 10m, a maximum gradient of 7% is acceptable, but with an incline 150m long, the gradient should be no more than 2%. Hills over 200m long should be no more than around 1 in 60 (1.7%).
- 4.14.6 The graph can also be used to look at options when the height difference is known. For example, when the height difference is 2m, either a 100m incline at 2% or a 60m incline at 3.3% is acceptable.

**Figure 4.5 – Relationship between height difference and desirable gradient**



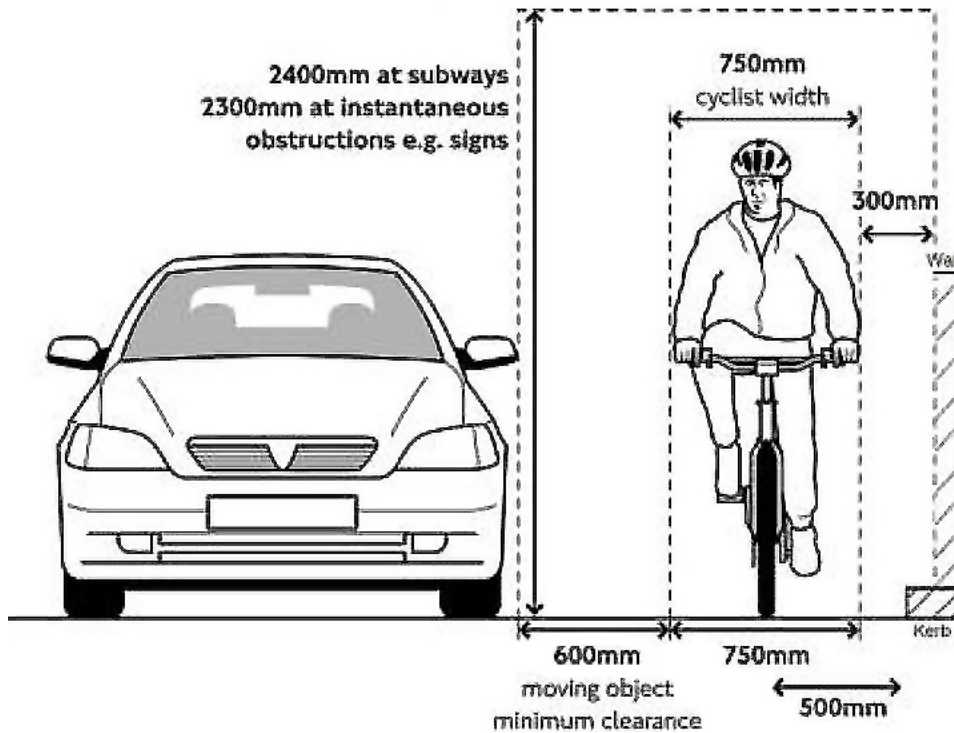
- 4.14.7 On uphill gradients cyclists' speeds will decline significantly below the 10-15 mph that could be expected from most cyclists on a level gradient. At even relatively modest uphill gradients of 3% or so, the speed achieved by a cyclist could fall to the level - typically around 7mph - at which the stability of the cycle is reduced. The additional space needed by slow moving cyclists should be considered.

- 4.14.8 On downhill gradients cyclists' speeds will rapidly increase, with a speed of 20-25mph easily achieved. Care should be taken to allow cyclists to maintain this momentum as much as possible, by increasing design speeds at the foot of inclines. Where space is limited it may be preferable to provide wide lanes or tracks for uphill cyclists. Downhill cyclists are more likely to be able to maintain a speed similar to general traffic and therefore may have less of a need for provision of cycle tracks or lanes.

## 4.15. Space for Cycling

- 4.15.1 Movements from side to side are necessary to stabilise a cycle when in motion: these lateral movements increase as speeds diminish. At a reasonable speed (7mph or above) the dynamic envelope required by a cyclist is approximately 1m in width, i.e. around 200 mm more than the width of the cyclist when stationary, thus making the typical dynamic envelope of 1m. At slower speeds, for example when cyclists are travelling up a steep gradient, it is greater.
- 4.15.2 The space required to cycle is normally more than this. It also needs to take into account:
- wobble room, so that cyclists of all abilities feel they have the space to move comfortably.
  - the position, height, width and profile of any continuous or intermittent physical barriers around pedal height, such as full-height kerb segregation or light segregation. Objects with a vertical profile need a wider clearance than rounded or sloping objects, and the risk of clipping a pedal is greater for higher kerbs
  - any physical barriers at handle-bar height or above, typically walls, guardrail, sign or signal poles and lamp-posts
  - the width of adjacent traffic lane(s) or, how close vehicles will come to encroaching on the cycling facility
  - the speed and width/type of vehicles moving alongside the cyclists
  - volume of pedestrians on adjacent footways
  - bus infrastructure
  - the geometry of the lane or track – cyclists require greater widths on curves, such as where the lane or track deviates around parked cars, loading bays, bus stops, etc.

**Figure 4.6 – Basic Space Requirements for Cycling**



**Note:** people using non-standard cycles may occupy more space – see Table 4.3

4.15.3 Based on guidance contained in LTN2/08, the recommended additional space (measured from the wheel) required to accommodate the fear of encountering any upstand or vertical structure parallel to the route is:

- 250mm for kerbs under 50mm high
- 500mm for kerbs over 50mm high
- 750mm to sign posts and lamp columns
- 1000mm to continuous features such as walls, railings or bridge parapets

4.15.4 In addition, cyclists may need to deviate from their path by around 500mm to avoid gullies or potholes.

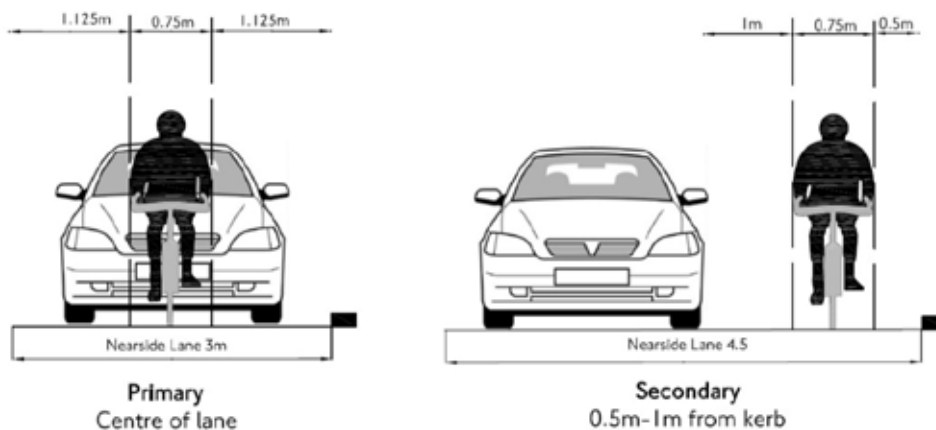
- 4.15.5 As with any form of transport, people cycling may be travelling with someone else. Cycling is a social activity and many people will wish to be able to cycle in comfort side by side, particularly in the case of parents accompanying children, or when they wish to safely overtake another cyclist. It is important that cyclists are able to choose their own speed so that they can make progress commensurate with the amount of effort they wish or can put in.
- 4.15.6 A clearance of 0.5m between dynamic envelopes is required for cyclists to pass or ride abreast comfortably and safely. Based on the typical dynamic envelope of 1.0m, this would mean that an effective width of 2.5m is required to permit safe overtaking or social cycling. A width of 2m allows these activities to take place with care, and should therefore be regarded as a desirable minimum on routes designed for one-way cycling. It should be noted that, with a lane or track width of 2.5m, many non-standard cycles cannot overtake or cannot be overtaken without difficulty.
- 4.15.7 Narrow (below 1.5m) cycle lanes should not be used on roads as they can place cyclists in greater danger, as there is evidence that the presence of the cycle lanes leads to closer overtaking by drivers (Parkin J & Meyers C, 2009).
- 4.15.8 When moving in opposing directions, there is a risk of head-on collisions, which can be severe if cyclists are moving at high speeds. At least 1.0m clearance between cyclists is therefore recommended. This gives rise to a desirable minimum width requirement of 3.0m for two-way tracks. This minimum width would allow overtaking or social cycling where there is a light flow in the opposing direction.

## 4.16. Cyclists and Motor Vehicles

- 4.16.1 The minimum clearance between a moving motor vehicle and the outside of the dynamic envelope of a cyclist should be 1.0m where the motor vehicle is travelling at 20mph or less, and 1.4m at 30mph or more. Where motor vehicles are more likely to include buses and other large vehicles, more clearance may be needed, and any measurement should be taken to the furthest side extremity of the vehicle. This has implications for the design of pinch points and for the width of general traffic lanes when cyclists are sharing carriageways, which are discussed below.

## Road positioning of cyclists

**Figure 4.7 - Primary and Secondary Road Positioning**



- 4.16.2 National Standards Cycle Training is taught in schools in Wales. It teaches pupils three levels of skills, from basic bike handling to riding on busy roads and junctions.
- 4.16.3 The training teaches cyclists to adopt two main riding positions when riding on carriageways – the primary and secondary positions. Designers need to be aware of these riding positions and design on-carriageway cycle routes with them in mind.
- 4.16.4 Cyclists are taught to ride in the secondary position, between 0.5-1m from the kerb or other fixed object, whenever it is safe and reasonable for them to do so, and it is safe for motor vehicles to pass them. This position ensures that they are far enough out to be able to avoid drains or debris near the gutter, but can also move in either direction to avoid potholes or utility access covers.
- 4.16.5 When the available width means that it is not safe for the cyclist to be passed, for example when approaching hazards such as side-roads, pinch points or junctions, the advice to cyclists is to take the primary position in the centre of the traffic lane. Using the centre of the lane increases the cyclists' visibility to other road users and reduces the risk of inappropriate or risky overtaking manoeuvres.



- 4.16.6 While this style of riding can be safe, it is unlikely to be attractive to more nervous, less experienced cyclists or those considering taking up cycling. It is therefore not appropriate to design active travel routes that depend on cyclists taking the primary position except in situations when motor traffic volumes and speeds are low.

## 4.17. Pinch Points

- 4.17.1 It is important to ensure that chicanes and pinch-points are designed in such a way that cyclists are neither squeezed nor intimidated by motor vehicles. The preferred option is to provide sufficient width so that the cyclist can remain in the secondary position and be passed safely. Alternatively, when speeds are low, the alternative is for cyclists to be placed in the primary position by keeping the space tight. This will not be desirable over long lengths, as cyclists will feel intimidated, unless motor traffic volumes are low. The appropriate widths are given in Table 4.6 below.

**Table 4.6 Lane widths at pinch points where no cycle track or bypass is provided**

Speed Limit	Lane width (m)	
	<5% HGVs	>5% HGVs
20 mph	2.5 maximum	3.0 maximum
30mph or above	4.0 <sup>†</sup> minimum	4.0 <sup>§</sup> minimum

<sup>†</sup> 3.0m may be used if frequent traffic calming measures are present along the length of road  
<sup>§</sup> Where 85th percentile speeds exceed 30mph, this should be increased to 4.5m

- 4.17.2 Table 4.6 shows that pinch points in the critical width range of between 3.1m and 3.9m should not be used. At this width drivers will be tempted to pass cyclists with insufficient clearance.

## 4.18. Road profiles and their effect on cyclists

- 4.18.1 In places where cyclists can be expected to share the road with other users, the width of the road profile has a profound effect on cyclists' comfort. Cyclists will feel uncomfortable if they sense that they are impeding motor traffic, while drivers may become impatient if they cannot easily overtake. This may in turn lead to closer overtaking manoeuvres, which are uncomfortable and potentially dangerous.

- 4.18.2 Designers should always be aware of the effect of their lane and carriageway width choices on cyclists, even if they are designing a route that has not been identified as an active travel route. The obligation for highway authorities to consider cyclists when discharging their general functions is discussed further in Chapter 9.

### **Critical Lane Widths**

- 4.18.3 Unless motor traffic flows are light, and drivers can cross easily into the opposing carriageway to pass cyclists, traffic lane widths of less than 3m or more than 4m should be used. Lane widths in the critical range of 3.2m to 3.9m should be avoided.
- 4.18.4 The effect on typical carriageway profiles is as follows (in streets with car parking the dimensions given below are based on the dimensions between parking bays).

### **Wide streets – 9m minimum two-way carriageway**

- 4.18.5 These widths give adequate space for drivers to overtake cyclists comfortably, however, speeds can be high. Within the overall carriageway width available consideration should be given to provision of cycle lanes or tracks, which should be wider where speed limits are higher.

### **Critical width streets – 7.3m two-way carriageway**

- 4.18.6 The 7.3m carriageway has been the default standard in the UK for many years, but it is important that designers recognise that this width often creates unsuitable conditions for cycling, and not of a standard that is now recommended under the Active Travel Act for active travel routes.
- 4.18.7 Where traffic volumes are low and sightlines are good, such roads can provide reasonable space for drivers to overtake safely by crossing into the other carriageway. Where volumes are higher, and drivers have to wait for gaps in oncoming traffic to pass cyclists, such roads create very uncomfortable conditions for cyclists, with drivers tempted into close overtaking.
- 4.18.8 Designers should therefore not use 7.3m wide carriageways unless cyclists are accommodated outside the carriageway, or traffic volumes are low, for active travel routes.

- 4.18.9 Where an existing 7.3m carriageway is being considered as an active travel route, it may be possible to make conditions suitable for cycling by reducing the speed and volume of motor traffic to recommended levels. Another alternative would be to make the route one way for motor vehicles, which would allow (for example) two 2m cycle lanes or tracks and a single 3.3m general traffic lane.
- 4.18.10 Simply providing narrow (<1.5m) advisory cycle lanes within a 7.3m carriageway is not a recommended approach.

#### Narrow width streets – 6m maximum two-way carriageway

- 4.18.11 Narrow roads are objectively safer for cyclists as drivers are less likely to be able to overtake, and cyclists are able to be more assertive in their use of the space. However, such streets should be short, traffic calmed, and designed to make it clear that cyclists have priority.

### 4.19. Road and path surfaces

- 4.19.1 Cyclists are particularly susceptible to uneven or hazardous road surfaces, such as potholes, ruts, poorly maintained ironwork or slippery surfaces. Most cycle crashes involve no other vehicle and many are due to poor surface conditions.
- 4.19.2 Rough surfaces also greatly increase the resistance and energy required to cycle the route, reducing comfort. Routes for cyclists must be constructed to be smooth, with bituminous surfaces laid by machine, rather than by hand. Care must be taken to ensure that routes near vegetation are constructed with a properly drained base course and designed to prevent root damage. As with any infrastructure, routine maintenance such as path sweeping, vegetation clearance and winter maintenance must also be provided on active travel routes, whether on or off-carriageway (see Chapter 10).

### 4.20. Summary of Cyclists' Needs

- 4.20.1 As with pedestrians, the design of the active travel network should ensure that cyclists are able to reach their destinations on routes that are coherent, direct, safe, comfortable and attractive. These needs are expressed in more detail as network requirements in Chapter 5.

### **Coherent**

- 4.20.2 The network must be coherent; it must link all the places cyclists want to start and finish their journeys with a route quality that is consistent and easy to navigate. Abrupt changes in the level of provision for cyclists – such a busy high speed roundabout - will mean that an otherwise serviceable route becomes disjointed and unusable by the majority of potential users.

### **Direct**

- 4.20.3 Routes for cyclists must provide the most direct and fastest route from origin to destination. In order to make cycling preferable to driving, routes for cyclists must be at least as direct – and preferably more direct - than that available for private motor vehicles. An indirect designated route for cyclists may result in some of them choosing the more direct, faster route, even if it is unsuitable for cycling

### **Safe**

- 4.20.4 Cycle networks must not only improve cyclists' – and other road users' – safety, but also their feeling of how safe the environment is. Consideration must be given to reducing the speeds of motor vehicles to acceptable levels, particularly when cyclists are expected to share the carriageway. The need for cyclists to come into close proximity and conflict with motor traffic must be removed, particularly at junctions, where the majority of crashes occur. Good quality surfaces are needed, not least to prevent cycle-only casualties.

### **Comfortable**

- 4.20.5 Smooth surfaces, with minimal stopping and starting, without the need to ascend or descend steep gradients and which present few conflicts with other users create comfortable conditions that are more conducive to cycling. The presence of high speed, high volume traffic affects both safety (as above) but also the comfort to the user.

### **Attractive**

- 4.20.6 People cycling are more aware of the environment they are moving through than those in cars or other motor vehicles. Cycling is a pleasurable activity, in part because it involves such close contact with the surroundings. The attractiveness of the route itself will therefore affect whether users choose cycling.
- 4.20.7 How these principles are applied in planning networks and routes is covered in Chapters 5 and 6.



## Key References

CROW (2006) Design Manual for Bicycle Traffic

Cycling Embassy of Denmark (2012) Collection of Cycle Concepts

Davies DG et al. (2003) Cycling in Vehicle Restricted Areas: TRL583

Department for Transport. (2013a) ATT0321: Confidence cycling on the roads

Department for Transport (2013b) RAS20006: Vehicles involved in reported accidents by junction type, vehicle type, built-up and non built-up roads, Great Britain 2012

Department for Transport (2013c) RAS54004: Estimates of the annual non-fatal road casualties in Great Britain using National Travel Survey data compared with casualties recorded in STATS19 (2008/12)

Department for Transport (2013d) Transport Statistics Great Britain 2013

Knowles J et al (2009) Collisions involving pedal cyclists on Britain's roads: establishing the causes, TRL PPR445

Parkin J & Meyers C (2010) 'The effect of cycle lanes on the proximity between motor traffic and cycle traffic.' Accident Analysis and Prevention. 2010 Jan;42(1):159-65.

Sustrans (2012) A Guide to Controlling Access on Paths

Transport for London (2011) Attitudes to Cycling

B

## 5 Network Planning

This chapter sets out the value of producing the integrated network map as required by the Active Travel Act. It focuses on the identification of improved active travel routes and facilities, of relevance to Section 1(b) of the Active Travel Act:

- b) for approved integrated network maps of the new and improved active travel routes and related facilities needed to create integrated networks of active travel routes and related facilities in a local authority's area.

### 5.1. Introduction

- 5.1.1 This guidance is to support local authorities in delivering their new duties, including audit tools that will help local authorities to decide whether a route is appropriate for active travel, and what steps should be taken to deliver improvements.
- 5.1.2 This chapter also advises on the range of evidence that should be used in developing such networks. As noted in Chapter 4, there are substantial differences between walking and cycling, and so there are key differences in the approaches to the planning of pedestrian and cycle networks.
- 5.1.3 It should be noted that although separate methodologies are given below for planning walking and cycling networks, there are some overlaps, particularly around data gathering and public consultation. Authorities should therefore consider whether it is appropriate to carry out these steps separately for walking and cycling; or whether it is better and more cost effective to deal with both active travel modes together.
- 5.1.4 The strategic planning of cycling infrastructure is typically based around the development of suitable routes and integrated networks, with existing provision being poor in many places. Walking routes within Welsh settlements have developed over a long period of time, with pedestrian facilities provided adjacent to almost all roads, ensuring that there is already a comprehensive network in most places to accommodate the vast majority of pedestrian trips. However, the walking network will often need to be improved to properly accommodate the needs of most pedestrians.

- 5.1.5 Network planning therefore needs to be specific to the mode of active travel for which the network should cater. The network planning process also needs to be adaptable to settlements of different sizes and demographics, which will in turn impact on the breadth of data required. Local user knowledge is a key source of information and views from relevant stakeholders should be sought at all stages of the process.

## 5.2. Existing Routes Map

- 5.2.1 The initial map to be produced will show the existing routes within the designated areas that are suitable and appropriate for making active travel journeys. Its purpose is to communicate to the public where routes are already suitable for active travel and to give them the information that they require in order to make decisions about how to travel.
- 5.2.2 In terms of network planning, the existing routes maps also provide a basis for establishing a clear understanding of the existing infrastructure, the gaps in existing provision and those routes or sections of route which do not currently conform to minimum standards of provision.
- 5.2.3 The process for producing these maps is set out in detail in Chapter 3.4 of the Delivery Guidance. It is an iterative process involving auditing, assessment, consultation and approval.
- 5.2.4 The first step will be to undertake an audit of existing routes. This should cover the conditions of the route, the levels of usage, its availability to different types of users and the nature and scale of any problems and potential improvements (Delivery Guidance 3.4.2).
- 5.2.5 These routes will generally be different for pedestrians and cyclists but some may be suitable for both – e.g. off-road, shared, and segregated or traffic free routes. The existing routes maps should also show crossing points and any facilities that exist to support active travel, including cycle shelters/parking/storage and public toilets.
- 5.2.6 Paragraphs 3.2.4, 3.2.6 and 3.2.8 of the Delivery Guidance show the types of facility and key features of a settlement that should be shown on the existing routes map, and also on the integrated network map.

### 5.3. Integrated Network Map

5.3.1 The second stage of the Act requires local authorities to develop integrated network maps which identify the proposed new and improved routes and the works required to create networks of the required standard. The steps involved in these processes are set out in the following chapters.

5.3.2 These integrated network maps must be prepared and submitted to the Welsh Ministers within three years of the commencement of Section 3 of the Active Travel Act, which took place on the 25 September 2014. The maps should set out the proposed route developments for each local authority over a 15 year period (Delivery Guidance 3.5.1 and 3.5.2). The integrated network maps will serve a number of roles - forming part of strategic plans, providing evidence for bidding documents for resources and for developing work programmes (Delivery Guidance 4.3.1).

#### **Integration**

5.3.3 Integration is key to the successful development and delivery of active travel networks. The networks need to be integrated with existing functions of the urban network, with other strategic plans and with a wider programme of measures to improve facilities for pedestrians and cyclists.

#### **Integration with other strategic plans and programmes**

5.3.4 Experience from the Netherlands, Germany and Denmark shows that the key to achieving high levels of cycling is the provision of good quality infrastructure “complemented by other measures such as ample bike parking, integration with public transport, the education and training of cyclists and motorists, and a wide range of promotional events intended to generate enthusiasm and wide public support for cycling” (Pucher & Buehler, 2008, pp 495).

5.3.5 The Cycling Demonstration towns in England have shown that for improvements to infrastructure to be successful they should be delivered within a wider programme which includes political commitment, skilled delivery teams, engagement, encouragement and promotion (Cycling England, 2010).

5.3.6 A similar integrated approach needs to be taken for promoting walking as a valid mode of travel for shorter everyday trips.

5.3.7 The network plans and their associated programmes of works therefore need to be integrated with wider strategic plans of the authority and external organisations. These plans might include:

B



### 5.3.8 Transport and Land Use Plans:

- existing walking, cycling or active travel plans
- plans or proposals for the development of non-vehicular routes, quiet lanes, home zones or traffic calming
- strategic bus plans or schemes
- rights of way improvement plans
- traffic management plans
- city centre management plans
- any Network Rail plans such as new stations, station improvements or changes to bridges or level crossings as part of the proposed electrification of the lines
- road safety strategies and schemes
- safe routes in communities schemes
- plans and strategies by third parties that include infrastructure provision for active travel
- Local Development Plans (including Supplementary Planning Guidance and Masterplans)
- Local transport plans
- Wales Transport Strategy
- National transport plans
- Highway maintenance plans
- Any plans for new highways (e.g. linking to new development sites)

### 5.3.9 Other Plans:

- community strategies
- crime reduction strategies
- children and young people's plans
- tourism, economic regeneration and community development proposals
- workplace strategies, including healthy living initiatives
- public health and physical activity plans and strategies
- social care and well-being strategies
- proposals for land use, including housing, commercial and industrial developments



- play sufficiency assessments
- plans for public spaces such as parks
- public realm improvement plans
- retail strategies
- alley gating plans

5.3.10 Direct contact with other local authority officers maybe the best way of identifying synergies with these other plans - not all information is necessarily available in a report or other data source. Workshops may be useful which would allow for discussions on the constraints and opportunities resulting from overlaps with other policies and implementation plans. Through discussions about the traffic and transport 'system' as a whole, such workshops also have the potential to help build lasting, perhaps even binding, agreements among the involved parties.

5.3.11 Key local authority officers include members from the following teams (this list is not exhaustive):

- transport policy
- public transport
- strategic planning
- development control
- urban design
- city centre management
- housing
- schools
- tourism
- countryside
- public rights of way
- highway maintenance
- access officers
- rehabilitation officers

- 5.3.12 When measures have been discussed for one transport mode, the consequences for other transport modes then become clearer. This integration will be of particular relevance at points within the networks where the different transport modes interact with one another such as junctions and interchanges (Dutch Ministry of Water, Energy and Transport, 2009).

### Non-Infrastructure Measures

- 5.3.13 The plans also need to be integrated within a wider programme of measures to improve facilities for active travel. The following non-infrastructure measures should be considered in conjunction with any walking and cycling improvement schemes:
- ensure that planning policy guides new development towards sustainable locations that maximise the potential for walking and cycling trips.
  - ensure that transport policy and highway development control processes result in new development site layouts that are designed to maximise access on foot and cycle.
  - ensure that the needs of pedestrians and cyclists are considered when implementing any changes to highway infrastructure.
  - encourage travel plans, which provide a strategy and action plan for facilitating and encouraging travel by sustainable modes, from all significant developments through the planning process.
  - explore the potential for new larger-scale developments to fund walking and cycling audits within adjacent neighbourhoods, potentially secured through section 106 agreements.
  - promotion of active travel through measures such as:
    - » production and dissemination of public walking and cycling maps, which should also provide information on public transport;
    - » organised activities for specific user groups, such as ‘walk/bike to school month’; and;
    - » dissemination of publicity regarding the potential health and financial benefits of regular active travel.
  - work with partners in the health sector to develop walking and cycling-based initiatives to help meet shared objectives for active travel.



### Integrated Network Maps

- 5.3.14 Integrated network maps are vital tools for developing and delivering the best possible active travel networks.
- 5.3.15 The existence of a map enables engagement with all of those people needed to make the networks a reality - politicians, engineers, funding bodies and the public, as well as the development of partnerships with health, education, commercial and voluntary bodies. Such engagement allows for the development of a sense of ownership of the planned networks both within the local authority and with the wider public.
- the maps are critical to designing each section of route within the networks. An effective design for any individual section is only possible if the designer understands its function with respect to adjacent links and within the overall network.
  - integrated network maps are invaluable tools to enable future improvement programmes to be developed, prioritised and managed. This represents a shift from the ad hoc provision for cycling and walking, that has so often happened in the UK helping to ensure that all infrastructure will contribute to the development of a comprehensive network for active travel.
  - the integrated network map enables authorities to gain access to a broader use of funds to develop networks, allowing other departments within the local authority, and outside organisations, to identify overlaps with their programmes. As discussed further in chapter 9, the highway maintenance department's resurfacing programme could be used to alter road markings to create cycle infrastructure, zebra crossings could be installed as part of a road safety junction improvement scheme or new footways could be included from the outset as part of a new development.
  - the delivery of active travel schemes could also be achieved through non-highway functions and organisations, such as public realm and environmental management projects and new developments, including developer contributions (s106 agreements and community infrastructure levy funding).
- 5.3.16 The evidence based, strategic nature of the network plan allows for the preparation of stronger funding bids (Delivery Guidance 4.3.1).
- 5.3.17 Authorities should look for opportunities for providing active travel routes through new developments when preparing the integrated network maps, since these can often be achieved without significant additional cost to the scheme as long as they are considered from the outset. Further guidance on new development is given in Chapter 9.

- 5.3.18 Similarly, development control officers should take the integrated network map into account when considering planning applications which affect it, whether because existing or proposed routes pass through the site or are close to it so that trips from the development could make use of them.

## Network Planning For Walking

### 5.4. Introduction

- 5.4.1 The Act covers a wide range of settlement types and pedestrian environments, with different datasets and resources available to each local authority.
- 5.4.2 This section of the guidance provides a number of suggested approaches to producing the walking element of the integrated network maps, with the flexibility for local authorities to adapt the approach to their situation.

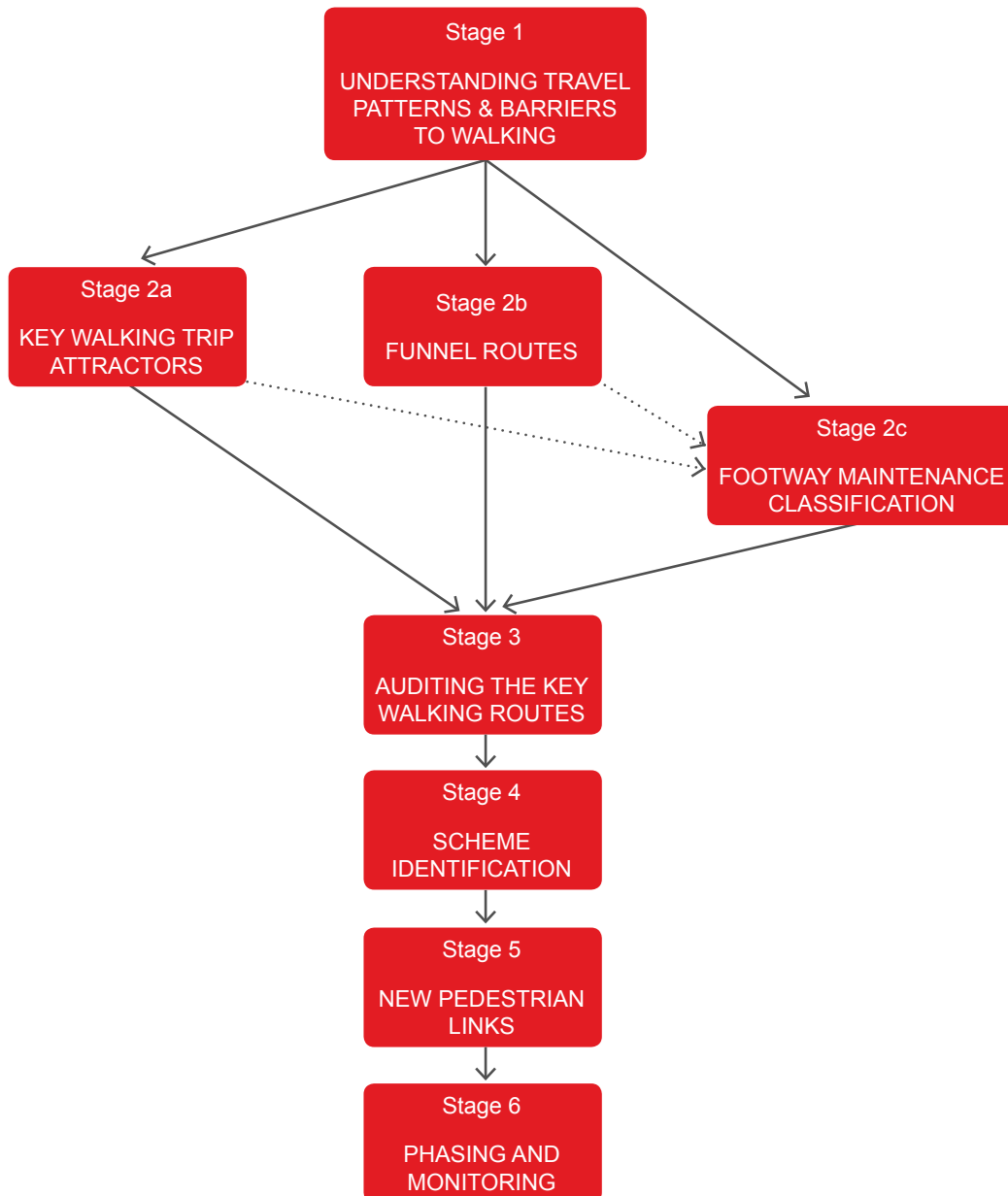
### 5.5. Methodology and Principles

- 5.5.1 As noted in the introduction to this chapter there is generally already a comprehensive network in place to accommodate most of pedestrian trips. The role of pedestrian network planning for utility trips in built-up areas is generally not to provide new walking routes per se, but to improve the existing network in order to encourage people to make more short trips on foot.
- 5.5.2 The question of where to focus investment is critical, and so this guidance outlines processes for identifying which parts of the pedestrian network should be prioritised for improvement and included on the integrated network map, based around three possible approaches to the critical Stage 2 of the process.
- a) walking trip attractors;
  - b) funnel routes associated with land-form barriers; and
  - c) footway maintenance classification.
- 5.5.3 These processes can be utilised in isolation to determine where to focus pedestrian infrastructure improvements. It is recommended, however, that authorities utilise a combination of the three approaches, tailored to local circumstances.

## 5.6. Process Stages

5.6.1 A process map for the recommended methodology, including the three approaches, is shown in Figure 5.1 below:

**Figure 5.1: Recommended Process for Network Planning for Walking**





### Stage 1: Understanding Walking Patterns & Barriers to Walking

- 5.6.2 The first stage is to assess barriers to walking and existing walking patterns using available local travel survey information. As noted above, there are overlaps with the information gathering stage of the cycle network planning process, and authorities may wish to combine these steps.

#### Existing Walking Patterns

- 5.6.3 Key walking journeys for analysis include commuting trips and the journey to school. The 2011 National Census provides publicly-available information on the 'Method of Travel to Work', which includes local authority, ward and detailed local (Output Area) data, and this can be used to assess existing walking patterns by geographical area.
- 5.6.4 The resources required to undertake pedestrian flow surveys over a wide area, to establish where the levels of pedestrian movements are highest, can be prohibitive.
- 5.6.5 However, it would be beneficial to utilise data on pedestrian movements from existing data sources, and to undertake a limited number of pedestrian flow surveys on specific routes, to confirm whether the level of pedestrian movements is as high as expected (applicable to Stages 2A and 2B), and also to help understand the relative level of pedestrian movements associated with the different footway maintenance categories (applicable to Stage 2C).

#### Barriers

- 5.6.6 Consultation with the public and stakeholders should be used to identify barriers to walking, preferably through a range of methods, to supplement the local knowledge of authority officers. Examples of barriers are discussed further in Stage 2B below.
- 5.6.7 Consultation with different user groups can also help ensure that local authorities exercise their duties under the Equalities Act 2010, (see Chapter 3). It is particularly beneficial to engage with children and young people, given the importance of walking as a mode of travel for the journey to school, and the potential for walking to have lasting positive impacts on the lifestyles of young people.

5.6.8 Possible forms of consultation include:

- workshops with representatives from relevant groups/organisations, such as disability wales, living streets and sustrans cymru, as well as local access focus groups and disabled people's organisations;
- online surveying of all residents in the settlement;
- public engagement events;
- community street audit; and
- discussions with local elected members.

5.6.9 Public consultations should ensure that residents' views on specific pedestrian issues are established. Feedback from local residents on specific walking issues forms a key part of the scheme identification outlined as part of Stage 4.

5.6.10 To help prioritise pedestrian infrastructure improvements, the consultation responses should be used to identify the local perceptions of the main barriers to walking, and to assess the relative influence of each barrier on overall walking levels. For consistency, the barriers should be categorised based on the criteria utilised for on-site auditing (see Stage 3).

**Stage 2A: Key Walking Trip Attractors**

5.6.11 Utility walking trips within a settlement do not generally have the same journey origin, as most walking trips start at homes spread across a settlement. However, utility trips typically have common journey destinations such as educational establishments, workplaces, health, leisure and other facilities. This guidance therefore outlines a methodology that focuses pedestrian network planning and improvements around these key walking trip attractors.

5.6.12 The Delivery Guidance provides examples of destination points that may be considered key walking trip attractors. These have been included in the list below to provide a guide to the types of local amenities that could be expected to attract a significant number of pedestrian trips:

- employment areas or large individual employers
- educational establishments (primary schools, secondary schools, colleges, university campuses);
- healthcare establishments (hospitals, health centres, doctors' surgeries);



- retail facilities (local retail centres, district retail centres, shopping parades/malls, supermarkets, retail parks);
  - community facilities (libraries, leisure centres, play areas & parks, religious buildings, cultural institutions);
  - venues (sports stadia, performance arenas, visitor attractions); and
  - transport interchange facilities (bus stops on core routes, rail stations).
- 5.6.13 The key walking trip attractors in each settlement should be located and mapped, including any proposed new facilities, initially in the process of producing the existing routes map, as required by the Act.
- 5.6.14 The relative size and likely level of pedestrian activity associated with each facility should be considered when deciding whether to classify it as a key walking trip attractor. For example, a large employment site may only attract a small number of pedestrian trips due to its location distant from the nearest residential areas, but a small employment site may attract a large number of pedestrian trips due to its central location within a settlement. Future changes, such as the planned opening or closure of facilities, should be considered. Latent demand for walking should also be considered, if improved pedestrian infrastructure has the potential to increase walking levels sufficiently to justify classifying a facility as a key walking trip attractor.
- 5.6.15 Research shows that preferred walking distances are short relative to cycling and travel by other modes. It is therefore recommended that the focus of pedestrian infrastructure is within the walking zones around key walking trip attractors, referred to as 'attractor zones'. In built-up areas, the number of pedestrian routes that are utilised by people in travelling to/ from an attractor increases as the distance from entry points increases. Therefore, the attractor zones can be defined using an approximate 5 minute walking distance of 400m (average walking speed) as a guide to the extents of the pedestrian infrastructure that should be assessed, with smaller areas used for small attractors and larger areas used for larger attractors.
- 5.6.16 Geographic Information System (GIS) applications can automatically draw walking isochrones of a set time/distance around defined points, which may be a useful tool in defining the zones around attractors, but this should be combined with an assessment of which routes are likely to accommodate high pedestrian flows. For example, a residential cul-de-sac may be a short walking distance from a key walking trip attractor such as a primary school, however, the cul-de-sac is unlikely to see a high level of pedestrian movement, and as such it may not be appropriate

for it to be prioritised and assessed for pedestrian improvements.

- 5.6.17 The process for defining attractor zones should utilise all available information, including local knowledge, to identify a zone within the vicinity of the key walking trip attractor that is likely to accommodate the majority of the pedestrian activity associated with the attractor. It is noted that the zones for different attractors are likely to overlap with each other, which will allow some zones to be merged.
- 5.6.18 The attractor zones then provide distinct boundaries of areas within which all pedestrian infrastructure is deemed to be important. It is then recommended that the pedestrian routes within these zones are audited on-site, as discussed in Stage 3 below.

### **Stage 2B: Funnel Routes**

- 5.6.19 Existing pedestrian networks within urban areas are fairly comprehensive and therefore generally provide a number of possible route options. However, barriers associated with the land-form or layout of a settlement can cause severance. This often creates routes with high pedestrian flows, as users are funnelled along the limited number of paths available, if they want to make particular journeys on foot.
- 5.6.20 Examples of barriers include steep changes in level, rivers, railway lines and heavily-trafficked roads with a limited number of crossing points. Railway and river bridges in densely populated urban areas, as well as their connecting junctions, often accommodate high pedestrian flows due to the lack of alternatives.
- 5.6.21 Other examples include residential and industrial estates with poor permeability for pedestrians, and with a limited number of access points to the wider network. This results in high pedestrian flows along the primary pedestrian access route(s). Parks and green spaces which are locked at night, or are not attractive walking routes outside of daylight hours, can also create funnel routes on the paths around them.
- 5.6.22 Funnel routes should be established from a desktop exercise using aerial imagery and other mapping, identifying barriers that sever the pedestrian network, and considering the structure and type of nearby land-uses and adjacent pedestrian routes. As noted in Stage 1, consultation with the public can also help identify barriers and hence funnel routes. Pedestrian 'spot counts' and on-site observations can be utilised to confirm whether the pedestrian flows appear to be high enough to justify assessing, auditing and potentially improving the route.

- 5.6.23 The identified funnel routes then represent pedestrian routes that are deemed to be important and which should be audited on-site, as discussed in Stage 3.

### Stage 2C: Footway Maintenance Classification

- 5.6.24 The guidance document 'Well-Maintained Highways: Code of Practice for Highway Maintenance Management' (RLG, 2005 Edition (2013 update)) provides recommendations to authorities that allow for the production of "positive and lasting maintenance policy". As part of the recommendations, a suggested footway hierarchy is defined (separate from the carriageway hierarchy that is used to categorise roads), with five broad categories for classifying the functionality and scale of use for routes, as reproduced in Table 5.1:

**Table 5.1: Recommended Footway Hierarchy**

	Name	Description
1(a)	Prestige Walking Zones	Very busy areas of towns and cities with high public space and streetscene contribution.
1	Primary Walking Routes	Busy urban shopping and business areas and main pedestrian routes.
2	Secondary Walking Routes	Medium usage routes through local areas feeding into primary routes, local shopping centres etc.
3	Link Footways	Linking local access footways through urban areas and busy rural footways.
4	Local Access Footways	Footways associated with low usage, short estate roads to the main routes and cul-de-sacs.

- 5.6.25 The Code of Practice recommends that the above hierarchy is utilised to classify all footways maintained by local authorities; there is no separate recommended hierarchy for Public Rights of Way (PRoW). The guidance indicates that this classification of footways "is a matter for local discretion", but should consider factors such as current/future pedestrian usage and contribution to the streetscene, as well as the "proximity to schools and other establishments attracting higher than normal numbers of pedestrians".



- 5.6.26 Although it is not a statutory requirement to follow the recommendations, maintenance teams in many Welsh authorities have classified their footways based on this approach, tailored to local circumstances, and some authorities have developed local maintenance policies based on the Code of Practice. It is therefore recommended that this defined classification of footways is used as a basis for establishing where to focus improvements to walking infrastructure under the Active Travel Act .
- 5.6.27 It will be useful to map the footway maintenance classifications, which may already be available from maintenance teams, using appropriate GIS applications.
- 5.6.28 Using the existing footway classifications, it is recommended that authorities prioritise auditing (see Stage 3), and the subsequent identification of pedestrian improvements (see Stage 4), starting with the higher category footways in each settlement.
- 5.6.29 It is recognised that there may not be any category 1(a) or 1 footways in some settlements, and in these cases it would be more appropriate to focus on category 2 and/or category 3 footways, and considering the length of footway that would need to be assessed.
- 5.6.30 The high category footways then represent pedestrian routes that are deemed to be important. It is recommended that these routes are audited on-site, as discussed in Stage 3.
- 5.6.31 It is recognised that the above process may not be possible for some local authorities, due to the lack of footway classification information. If this is the case, then the approaches detailed in Stage 2A and Stage 2B can be utilised instead. However in this case, input from the authority's Highway Maintenance Team should still be sought to ensure that the integrated network map reflects their requirements.

### **Stage 3: Auditing the Key Walking Routes**

- 5.6.32 Stage 2 has enabled authorities to identify the most important pedestrian routes within each settlement. The next stage of the process is to audit the existing infrastructure along the routes and in areas that have been identified.
- 5.6.33 The aim of the audit process is to identify where pedestrian infrastructure improvements are needed, with sufficient detail obtained on-site to enable the scope and indicative cost of schemes to be estimated, and to assemble packages of potential improvement works.

- 5.6.34 There are a number of potential methodologies for auditing walking infrastructure, ranging from detailed street audits, to surveys that only consider specific aspects of the infrastructure (such as footway condition surveys). It is recommended that the auditing methodology should target the following five considerations for pedestrian infrastructure.
- comfort
  - attractiveness
  - accessibility
  - directness
  - safety
- 5.6.35 This checklist substitutes accessibility for coherence since in most circumstances the walking network is already reasonably comprehensive, however, the standard of the infrastructure may mean the route is not always accessible.
- 5.6.36 Based on these 5 key considerations, a recommended audit checklist has been developed, which defines the pedestrian environment in terms of 21 individual categories to be assessed on-site, (20 of which are scored) as given in Appendix B.
- 5.6.37 Any route which scores less than 28 (out of a potential 40 points, ie a score of 70%) will require further improvement before it is included in the existing or integrated network maps. This threshold will be kept under review in the light of experience.**
- 5.6.38 The auditing should cover the different types of pedestrian routes that are being considered for active travel routes, including footways adjacent to roads and other non-highway footpaths to which the public have access, as appropriate.
- 5.6.39 If a large number of pedestrian links/routes are to be audited, then it is suggested that a simple scoring system is utilised, to highlight where there are existing deficiencies/issues. Pedestrian links can be scored as green, amber or red against the 16 infrastructure categories outlined in Appendix B.
- 5.6.40 Authorities can tailor the audit process to their local situation, considering the nature and scale of improvement schemes that they would be looking to propose, and the resources they have available to carry out the work. It may be appropriate to undertake detailed street audits if the extents of the pedestrian environment to be assessed are manageable.



- 5.6.41 In order to ensure that the methodology for auditing existing infrastructure accounts for the views of different user groups, it may be useful to undertake a pilot street audit with representatives from the various user groups, including people with different types of disabilities.
- 5.6.42 This information can form the basis of the Statement and Explanation, required to accompany any routes on the existing route map that are not up to standard, but suitable for mapping none the less. The delivery guidance contains more information about the statement and explanation.

#### **Stage 4: Scheme Identification**

- 5.6.43 Potential schemes that can be implemented to improve pedestrian provision and address existing deficiencies include:
- replace broken/uneven/rocking pavements;
  - resurface footways;
  - improved street lighting;
  - provision of CCTV security cameras;
  - improved pedestrian crossing facilities;
  - removal of street clutter;
  - provision of traffic calming features;
  - reduced road speeds;
  - provision of dropped kerbs and tactile paving; and
  - public realm improvement schemes encompassing some or all of the above.
- 5.6.44 As part of the public engagement events (see Stage 1), local residents should be asked to highlight specific infrastructure issues, to help identify possible improvement schemes. Further analysis should be undertaken to critically assess the scale and nature of the issues raised by the public, with a focus on issues that have been raised by multiple residents.
- 5.6.45 Other key stakeholders – such as Disability Wales, Living Streets and Sustrans Cymru, local access focus groups and disabled people's organisations - should also be involved in site visits to discuss the walking infrastructure and potential improvements on key pedestrian routes. It may also be beneficial to consult with internal departments/colleagues, particularly Access and Rehabilitation Officers.

- 5.6.46 Where a number of schemes have been identified within the same zone, or on the same route, it may be appropriate to merge the schemes into a package of works, to help ensure that individual measures are implemented together and to achieve complementary benefits and synergies.
- 5.6.47 It may be necessary to prioritise improvement schemes (and packages of schemes) for funding and implementation – this is a matter for local discretion. However, relevant factors to consider in prioritising pedestrian improvements include:
- the current and potential levels of pedestrian movements;
  - the importance of the route for specific user groups;
  - the degree of deficiency of the existing infrastructure;
  - previous, current and planned levels of investment in the public realm;
  - integration with facilities for other transport modes, particularly cycling and public transport;
  - performance against local transport policy objectives;
  - scheme feasibility / deliverability;
  - potential to attract funding, particularly private sector funding; and
  - implementation costs.

### **Stage 5: New Pedestrian Links**

- 5.6.48 In addition to improvements to the existing pedestrian network, there may still be a requirement to provide new links in order to ensure that pedestrian routes are as direct and safe as possible. Pedestrian desire lines that are not facilitated by a suitable pedestrian facility can be identified from a number of sources, including:
- Requests from the public, local elected members and key stakeholders;
  - Evidence of worn pathways across grassed areas, which may be noted from the on-site auditing of existing pedestrian routes (see Stage 3); and
  - Analysis of barriers can highlight where facilities such as new crossing points and bridges could potentially accommodate a high number of pedestrian trips, with demand currently suppressed by the limited number of route options.



5.6.49 In assessing potential new links, the requirement of the Act to focus on utility trips should be considered - routes that are only likely to provide for leisure/recreational walking trips are not suitable for inclusion on the integrated network map.

### **Stage 6: Phasing & Monitoring**

5.6.50 The settlements covered by the Act range in size from small villages to large cities, and as such the number of pedestrian routes to be assessed will vary substantially. It is acknowledged that local authorities may not have the resources to audit, assess and identify improvements across the whole of a larger settlement in one phase, therefore some authorities may need to phase the assessment work by dividing settlements into sub-areas. There are a number of potential ways to undertake this.

5.6.51 A recommended approach to phasing is to utilise local-level data from the 2011 National Census to identify areas with statistically lower levels of accessibility, using the census dataset for 'proportion of households without access to a car/van' and higher levels of poor health. This will help to address key objectives through enhancing walking infrastructure that improves access to key amenities. The boundaries used by the census geography are built for the purposes of statistical analysis, therefore it may be necessary to refine the boundaries to provide more intuitive area boundaries for the public and other stakeholders.

5.6.52 To establish the impact of any implemented walking improvements, monitoring of walking levels and travel patterns should be undertaken before and after implementation. The surveys and consultations undertaken to inform the development of the programme of works (see Stage 1) should provide a representation of existing 'before' walking patterns. Once the schemes that are to be implemented as part of the network planning assessment have been determined, and the geographic extents of implementation have been defined, the obtained information on views and perceptions regarding walking can be supplemented by pedestrian flow counts at key locations.

5.6.53 In order to monitor the impact of implemented measures, 'after' surveys should be undertaken a suitable period after implementation. It is important that the brief for the 'after' surveys is consistent (through consideration of factors such as time, day of the week and weather conditions) with the 'before' surveys, to ensure that the results provide a direct comparison.



## Network Planning For Cycling

### 5.7. Introduction

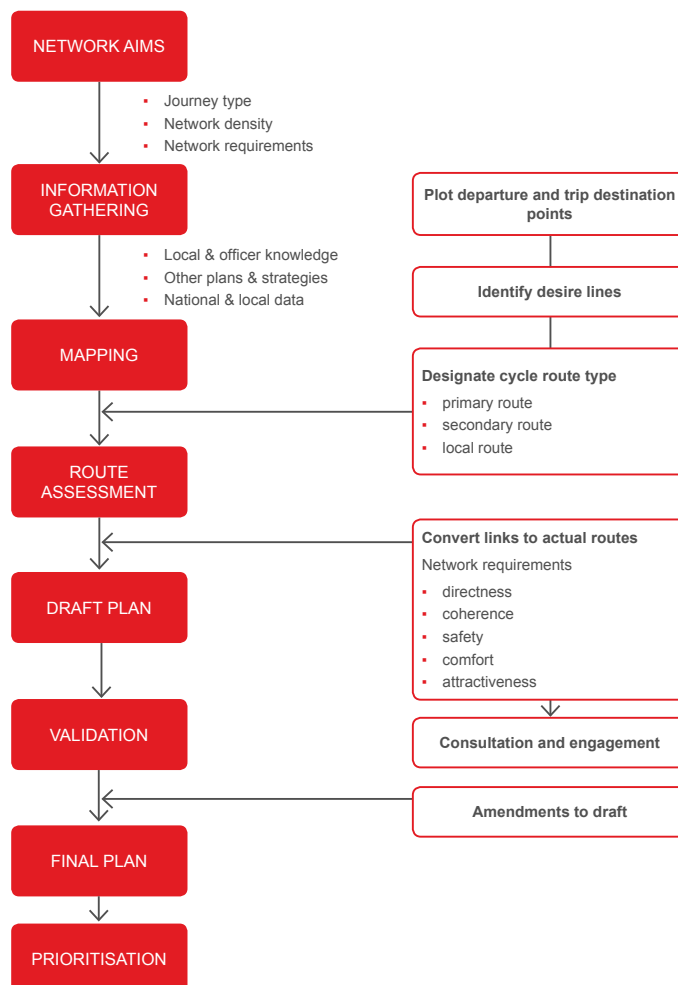
5.7.1 This section of the guidance provides a recommended approach to preparing the cycling element of the integrated network maps. It is based on European best practice, amended as necessary to suit the legislative framework applying in Wales.

5.7.2 This process can be adapted to suit local circumstances and the degree of sophistication of the cycling network plan will depend on the size of the area under consideration.

### 5.8. Process Stages

5.8.1 Figure 5.2 sets out the stages to be undertaken when developing a cycling network plan:

**Figure 5.2: Recommended Process for Network Planning for Cycling**





### 5.8.2 The stages are:

- network aims – the journey types it should cater for, its density (the distance between routes within the network) and the key network requirements.
- information gathering from a broad range of sources including local and officer knowledge, strategic plans, and national and local data.
- mapping, which involves plotting the trip departure and destination points, identifying desire lines and designating route types.
- route assessment involves translating desire lines into actual routes, using existing routes and streets wherever possible. The suitability of routes is assessed against the key network requirements.
- the Draft network plan indicates the routes to be developed and the improvements required to bring those routes up to standard.
- validation is required through effective consultation and engagement.
- the final integrated network map can be sent to Welsh Government for approval once any necessary amendments have been made.

5.8.3 A further additional stage is the **prioritisation** of the works required to create the routes based on local and national policy, any overlaps with other programmes of works and the availability of funding.

#### **Stage 1: Network Aims and Requirements**

5.8.4 Establishing network aims is crucial to understanding the focus of the network development and informs all of the proceeding stages of planning.

#### **Journey Type**

5.8.5 Cycling generally has two main purposes - utility and leisure.

5.8.6 Utility cycling involves making a journey for the main purpose of doing an activity at the journey's end, such as work, education or shopping whereas leisure cycling is done for the journey itself. Leisure cyclists include sports training cyclists, recreational riders and cycle tourists (LTSA 2004).

5.8.7 The Active Travel Act is aimed at promoting and enabling utility journeys.

5.8.8 The definition of 'active travel' under the Act means walking and cycling as an alternative means to motorised transport for the purpose of making everyday journeys. An "active travel journey" means a journey made to

or from a workplace or educational establishment or in order to access health, leisure or other services or facilities (Delivery Guidance 2.3.1).

- 5.8.9 This Delivery Guidance also explains (2.3.2) that: Where routes could not be used to access a workplace or educational establishment, health, leisure or other services or facilities, then they are not suitable to be considered as active travel routes (Delivery Guidance 2.3.2)
- 5.8.10 When developing their active travel networks, local authorities should be clear what the aims of the network are, the journeys they are planning to cater for and the people they are hoping will use the network.

### Network Density

- 5.8.11 If a cycle network is viewed as a grid or mesh that is laid across an area, and the designated routes are the lines of the mesh, then the density can be measured by the distance (typically crow-fly) between the designated routes. This distance between routes is referred to as the “mesh width”.
- 5.8.12 The networks developed under the Active Travel Act should aim to have a mesh width of around 250m to create as dense a network of cycle routes as possible. However it is acknowledged that it will take time to develop a network of such density and wider mesh widths of 500-1000m would be expected within the initial years of the network development. The Act acknowledges that these cycle networks will not be delivered overnight and the ‘integrated network maps should set out the plans of the local authority for the next 15 years’ (Delivery Guidance 3.5.2).
- 5.8.13 The density of the network will also be in part defined by the size and layout of each settlement. In smaller towns (less than around 2000 residents) the network could potentially include every possible route from the outset. In larger towns and cities this would have to be simplified by clustering certain destination or departure points - for example by only including larger employment sites (e.g. where more than 100 people are employed) or only the larger shopping areas.
- 5.8.14 Whatever the density of the designated routes, the key to delivering a truly comprehensive network is the principle of the basic network. This means that most roads within a settlement, i.e. the residential and lightly trafficked parts of the network, should be designed to allow for the safe movements of cyclists, since every home, employment location and amenity should be accessible by cycle. The power of the cycle is in its flexibility, speed and convenience. These advantages can only be exploited if as many routes as possible are suitable for cycling. The basic



network is therefore not only the designated cycle routes but the majority of the road network (with a few exceptions such as most trunk roads, other high speed roads and motorways).

- 5.8.15 Different levels of provision would be expected on the designated routes as compared to the local routes which typically make up the basic network but the principle means that authorities should consider the safety of cyclists on most streets. This is a shift from previous practice in the UK which typically focused heavily on providing a limited number of designated cycle routes.

### **Network Requirements**

- 5.8.16 A number of factors have been identified as being key requirements to creating a usable cycle network – see Chapter 4, User Needs. Routes should be:
- coherent
  - direct
  - safe
  - comfortable
  - attractive
- 5.8.17 The first three of these key factors (i.e. coherence, directness and safety) are of greater importance in the design of the overall cycle network, whereas comfort and attractiveness play more of a role in the design of the routes themselves.
- 5.8.18 The relevance of each of these factors in network planning is set out in Table 5.2

Table 5.2: Cycle Network Requirements

Key requirement	Principle	Recommendation
Coherence	Continuity of routes	<p>Cyclists should be able to easily and safely join and navigate along different sections of the same route and between different routes in the network.</p> <p>Routes should be complete with no gaps in provision. 'End of route' signs should not be installed but rather cyclists should be shown how the route continues. Cyclists should not be 'abandoned' by the infrastructure, particularly at junctions where provision will often be required to ensure safe crossing movements.</p>
	Density of network	Cycle networks should provide a mesh or grid of routes across the town or city. The density of the network is the distance between the routes which make up the grid pattern. The aim, possibly in the longer term, should be a network with a mesh width of 250m.
Directness	Distance	Routes should follow the shortest option available or as near to the 'as-the-crow-flies' distance as possible. It is recommended that routes be no longer than 1.4 x 'as-the-crow-flies' distance.
	Time: Frequency of required stops	The number of times a cyclist has to stop on a route should be minimised. This includes stopping at junctions, access (motorcycle) barriers, give way points, pedestrian only zones etc.

B

Key requirement	Principle	Recommendation
Directness	Time: Delay at junctions	The delay caused by junctions should be minimised. This includes assessing the impact of multiple or single stage crossings; signal timings, toucan crossings etc.
	Time: Delay on links	The delay caused by not being able to bypass slow moving traffic.
	Gradients	Routes should avoid steep gradients. Uphill sections increase time, effort and discomfort. Where these are encountered, routes should be planned to minimise climbing gradient and allow users to retain momentum gained on the descent. However in some circumstances short steeper sections may be better than long slower gradients. The routes should be cycled to assess the relative impact of gradient on time, effort and discomfort.
Safety	Reduce/ remove speed differences	Key to reducing severity of collisions is reducing motor traffic speeds, particularly at points where the risk of collision is greater, typically at junctions.
		Where cyclists and other vehicles are sharing the carriageway speeds should be reduced to more closely match that of the cyclist.
	Risk of collision	Where speed differences cannot be reduced cyclists should be separated from traffic. This separation can be achieved at varying degrees through on-road cycle lanes, light segregation, hybrid tracks, and full segregation. Segregation will reduce the risk of collision from beside or behind the cyclist and improve subjective safety.



Key requirement	Principle	Recommendation
Safety		<p>A high proportion of collisions involving cyclists occur at junctions, which need particular attention to reduce the risk of collision.</p> <p>Junction treatments include:</p> <ul style="list-style-type: none"> <li>▪ minor/side roads - cyclist priority and/or speed reduction across side roads</li> <li>▪ major roads - separation of cyclists from motor traffic through junctions.</li> </ul>
	Reduced conflict with crossing traffic	<p>Routes should be identified which reduce the number of crossing points or junctions that a cyclist needs to negotiate (see Stopping Frequency above). Where junctions cannot be avoided they should be designed to be low speed or with segregated provision.</p>
	Avoid complex design	<p>Avoid complex designs which require users to process large amounts of information. Good network design should be self-explanatory and self-evident to all road users. All users should understand where they and other road users should be and what movements they might make.</p>



Key requirement	Principle	Recommendation
Safety	Consider all user demands	<p>Routes should be assessed in terms of all multi-functional uses of a street including car parking, crossing, pedestrian movements etc. Routes should not be implemented where there is excessive conflict with existing uses, unless the existing use can be removed or modified.</p> <p>In terms of pedestrian/cycle interaction</p> <ul style="list-style-type: none"> <li>▪ introduction of good quality on-road cycle provision can enable less confident people to cycle without using footways, which are not suitable for shared use</li> <li>▪ designating footpaths as shared use can be acceptable in some circumstances, however</li> <li>▪ introducing cycling onto well-used footpaths will reduce the quality of provision for both users if the provision does not meet the recommended standards</li> </ul>
	Reduce severity of collisions where they do occur	Wherever possible routes should include “evasion room” (such as grass verges) and avoid any unnecessary physical hazards such as guardrail, build outs, etc. to reduce the severity of a collision should it occur.
Comfort	Separation from traffic fumes and noise	In addition to reducing the number of encounters with traffic and pedestrians, routes should also be avoided where a cyclist is exposed to fumes and noise from heavy traffic over long distances.





Key requirement	Principle	Recommendation
Comfort	Surface quality	Defects, including non cycle friendly ironworks, raised/sunken covers/gullies, potholes, poor quality carriageway paint (e.g. from previous cycle lane) should be minimised. Smooth pavement or carriageway construction, preferably with Stone Mastic Asphalt or blocks/bricks/sets.
	Effective width without conflict	Cyclists should be able to comfortably cycle without risk of conflict with other users both on and off road.
	Wayfinding	Non-local cyclists should be able to navigate the routes without the need to refer to maps.
Attractiveness	Social safety and perceived vulnerability of user	Routes should be appealing and be perceived as safe and usable. Well used, well maintained, lit, overlooked routes are more attractive and therefore more likely to be used. Some routes, particularly those that are more secluded, may require mitigation (such as lighting, removal of litter and graffiti, and maintenance of vegetation growth especially where it may impact on visibility) and the identification of alternative routes, particularly for use outside of daylight hours.
	Minimise street clutter	Street clutter should be minimised, although essential directional signing will be required enabling wayfinding.
	Secure cycle parking	There should be easy access to secure cycle parking at both the start and end of journeys for all types of user.





### Importance of cycling the route

- 5.8.19 The recommended method for assessing routes against these requirements is to cycle them, as it is only when they are experienced first-hand that the issues can be more fully understood. This understanding will result in better design and more usable routes. Local and user knowledge is also a crucial input and views should be sought throughout the process to ensure the best possible routes and solutions are identified.

### Application of principles to all highway schemes

- 5.8.20 Following these principles in the design of all highway schemes will allow as many all-purpose roads within the network as possible to provide properly for active travel. This is discussed in greater detail in Chapter 9.

### Stage 2: Information Gathering

- 5.8.21 A broad range of information should be gathered when developing the cycling elements on the integrated network map. The need for this will depend to some extent on the size of the settlement, but collecting more information is likely to increase the quality of the final network and therefore the take-up active travel.
- 5.8.22 As noted above, there are overlaps with the Understanding Walking Patterns and Barriers to Walking stage of the pedestrian network planning process, and authorities may wish to combine these steps.
- 5.8.23 Information should be obtained on
- the journeys that people currently make (by all modes of transport),
  - their trip departure and destination points
  - the barriers they perceive to cycling or cycling more often,
  - their views on existing routes and
  - their requests for improvements and potential new routes.
- 5.8.24 This information can be gathered through a variety of means including surveys, workshops, social media and exhibitions, both on-street and in nearby buildings. Local authorities could undertake surveys of the public's expectations and requirements for walking and cycling routes and facilities. This may include assessing the needs locally of specific user groups, such as disabled people. Surveys might also help to assess the extent to which people are making short car journeys due to a lack of knowledge of alternative methods, poor or missing infrastructure provision or because their journey was unsuitable for active travel. (Delivery Guidance 3.5.10)

B



### National Data

5.8.25 There is a broad range of publicly available data which can usefully input into the development of an Integrated Network Map, including:

- ward boundary map
- census – ward-to-ward travel to work data by mode
- NOMIS ward-to-ward travel to work patterns
- demographic profile maps
- residential and workplace population data
- cycling to work data
- cycle collision data (e.g. [www.crashmap.co.uk](http://www.crashmap.co.uk))
- road network hierarchy
- Department for Transport – traffic counts – Wales  
<http://www.dft.gov.uk/traffic-counts/area.php?region=Wales>
- traffic and cycle count location plan
- traffic and cycle flow data
- Welsh Index of Multiple Deprivation  
<http://wales.gov.uk/statistics-and-research/welsh-index-multiple-deprivation/?lang=en>
- other open source data

### Local Data

5.8.26 Local authorities already collect a range of data which can usefully input into the cycle network plan including:

- locally collected traffic and cycle count location plan
- locally collected traffic and cycle flow data including off road cycle counters
- locally collected traffic speed data
- data collected as part of travel plans for specific organisations within the settlement
- existing traffic calmed streets
- housing monitoring maps



- 5.8.27 Where necessary local authorities may need to carry out additional cycle and traffic counts or speed surveys on specific streets or routes where no data already exists. This needs to be used in the context of the existing and envisaged use by motor vehicles and cyclists.
- 5.8.28 In particular, care needs to be taken to ensure that seemingly 'safe' routes with low casualty levels are not actually heavily trafficked routes that no one would wish to cycle on (and hence show very low casualty levels).

### Stage 3: Mapping

5.8.29 Once the relevant information has been gathered the mapping stage can be undertaken. The mapping stage should be developed through a process of layering all of the relevant information from the various sources discussed above.

5.8.30 The mapping stage involves the following steps:

- a) map trip departure and destination points
- b) plot links between them
- c) designate route type

### Plot Trip Departure and Destination Points

- 5.8.31 Trip departure points are usually the main residential areas of the settlement. Depending on its size and the required density of the network, the departure points can be clustered – see below.
- 5.8.32 Trip destination points generally cover all of the buildings and amenities that might attract existing and potential cyclists.
- 5.8.33 For the Active Travel Act the mapping of the following departure and destination points will need to be completed as part of the production of the existing routes map
- main office locations and business parks
  - public transport nodes
  - libraries
  - post offices
  - sports stadia
  - leisure centres
  - parks

- religious buildings
- hospitals
- shopping centres
- educational establishments
- cultural institutions
- tourist advice centres
- tourist and leisure attractions
- recreational walking and cycling routes
- cycle maintenance and repair shops

5.8.34 However based on the information gathered during the previous stage additional points may need to be added which are planned within the period of the network plan, such as residential areas, railway or light rail stations, business parks, schools etc.

5.8.35 Local authorities should also consider destination and departure points in neighbouring local authorities where the distance is not too great (less than 10 miles) to prevent active travel being overlooked as a viable transport option between different local authority areas. It is recommended that wherever possible settlements in different local authorities are connected through the active travel networks, which should be developed through collaborative working (Delivery Guidance 3.5.9).

#### Clustering of departure/destination points

5.8.36 Once all of the new and proposed departure and destination points have been mapped they will need to be clustered to reduce the complexity of identifying desire lines.

5.8.37 The clustering will depend on the size of the settlement and the density of the network being developed. For larger towns and cities this clustering might be done by only including larger employment sites (e.g. where more than 100 people are employed) or only the larger shopping areas.

5.8.38 For example when developing the Cardiff strategic cycle network plan

- homes within a neighbourhood were clustered and identified by one key point (e.g. the main hub or row of shops within the neighbourhood)
- employment centres such as Cardiff Bay were identified as one key destination point



5.8.39 Clustering on this scale would not produce a network plan of a density of 250m mesh width. However the initial integrated network map is the first phase in a long term plan for developing a network. Once the first phase of routes are developed, networks with routes that have a closer mesh width can be identified and created and so on until eventually the network will have the desired density.

### Identify Desire Lines

5.8.40 Once trip destination and departure points have been mapped (and clustered where required) the next step involves plotting the desire lines between them. These desire lines should be direct and should not follow existing roads or cycle routes – all that is needed at this stage is to identify the lines along which people want to travel. This can be carried out independently of the existing routes maps. The existing routes map will be an invaluable tool when converting desire lines to actual routes, but the identification of desire lines should not be constrained by existing routes.

5.8.41 The plotting of desire lines requires an understanding of who wants to go where, as not all destination points need to be linked to all departure points. The identification of the desire lines should be based on the data, research and local knowledge collected in the information gathering stage.

5.8.42 For example, not every residential area needs to be linked to every school as generally schools have catchment areas (although this may not be applicable to Welsh language medium or religious schools) so the links need only be identified within those catchment areas. Census data can provide extensive information on residential and workplace populations which can be used to identify potentially useful links.

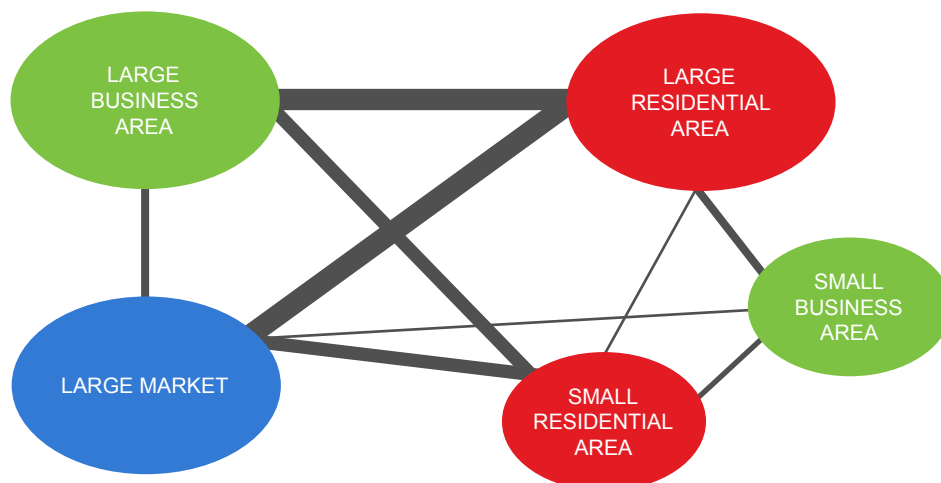
5.8.43 This methodology is scalable - a considerable amount of analysis may be appropriate to identify the required cycle route network in a city but within smaller towns and villages the desire lines may be more self-evident.

### Identify Cycle Route Type

5.8.44 Prior to converting the desire lines into actual routes the importance of the route needs to be understood, in terms of the numbers and types of cyclists it will need to cater for (e.g. links to schools will naturally need to cater for younger people's needs).

- 5.8.45 This process informs the designation of route type. These route types are similar to the hierarchies used to identify different levels of service for motor traffic that would be expected on trunk roads, distributor roads and residential streets.
- 5.8.46 The following hierarchy of cycle routes is recommended:
- **Primary routes:** key corridors between neighbourhoods/residential areas and a town or city centre; key routes between districts and neighbourhoods within a town or city; cycle routes which are (or will be) used by a great many cyclists
  - **Secondary routes:** links between the primary routes; links to trip attractors such as schools, colleges, employment sites; cycle routes which are an attractor for a more limited range of users; routes which will cater for fewer cycle journeys than the primary routes but are still of strategic importance within the network
  - **Local routes:** all other all-purpose roads which are not necessarily part of a designated route (e.g. many residential streets). This basic network of local routes, although lower in the hierarchy, form an important part of the cycle network.
- 5.8.47 Showing the demand lines at this stage can be done by using varying thickness of line to show the different levels of route - see example Figure 5.3. This shows a stronger relation between a large residential area and a large city market in comparison to that between a large residential area and a small residential area.

**Figure 5.3 – Illustrative Demand Lines Diagram**



## Stage 4: Assessment

### Convert Desire Lines to Routes

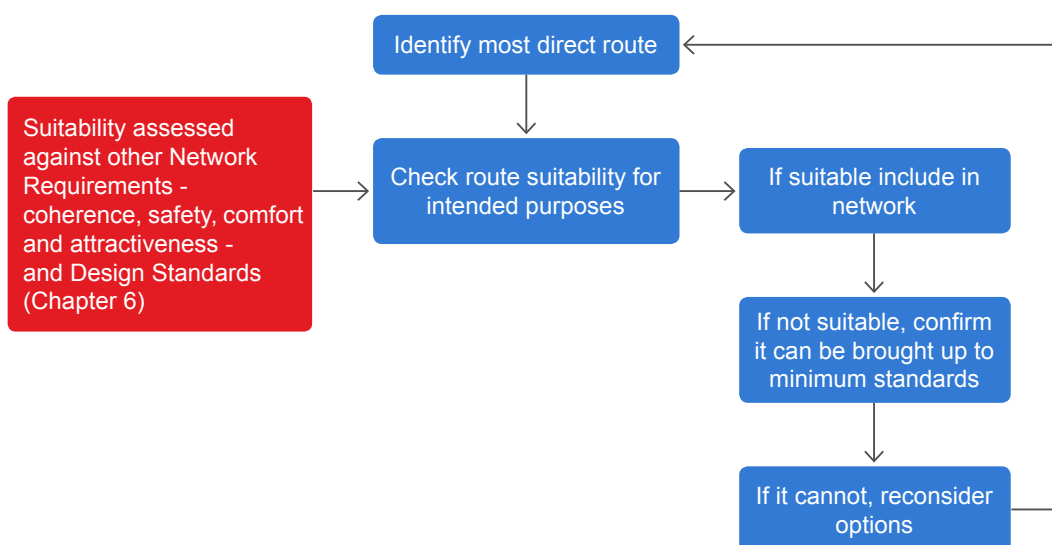
5.8.48 This stage is the most critical and involves translating the desire lines into actual routes. Authorities should aim to make as much use as possible of existing infrastructure and any new infrastructure that is already planned – for example any new roads and streets being provided by new housing development sites.

5.8.49 This identification of routes should be based on a clear understanding of the key requirements of the cycle network set out in Table 5.2 and the design standards set out in Chapter 6.

5.8.50 The conversion of desire lines to routes involves the following steps, which are illustrated in Figure 5.4.

- 1) identify the most direct route available (based on directness requirements of time, distance and gradient)
- 2) check the route is suitable for the intended use (based on the coherence, safety, comfort and attractiveness of the route);
- 3) if not, confirm that the route can be brought up to minimum standards;
- 4) if it cannot, identify the next best route and start again from stage 2.

**Figure 5.4 – Convert Desire Lines to Routes**







### 1. Identify Most Direct Route

- 5.8.51 Where there are a number of potential routes between points, they will all need to be assessed to determine which is the most direct in terms of the factors given in Table 5.2 namely distance, time (stopping frequency and delay) and gradient. Reference should also be made to the basic user needs given in Chapter 4.

### 2. Check suitability of route

- 5.8.52 The most direct route should then be assessed for its suitability. This assessment involves the appraisal of the route in terms of the other key requirements of coherence, safety, comfort and attractiveness given in Table 5.2 and the design guidance and standards set out in Chapter 6.
- 5.8.53 An Audit Tool has been developed to assist in this task, which is included in Appendix B. It is intended to be used on-site and provide a means of ensuring that all of the factors which make up the key requirements are considered.
- 5.8.54 Any route which scores less than 35 (out of a potential 50 points, ie a score of 70%), or has any element that is marked as 'Critical' will require further improvement before it is included in the Existing or Integrated Network Maps. This threshold will be kept under review in the light of experience.**

### 3. If Not Suitable, Identify Improvements Required

- 5.8.55 If the route is not suitable in its current condition, an assessment should be undertaken to identify the works or measures that would enable it to fulfil the network requirements and the design standards, based on the following considerations:
- there is often more than one solution – street design is not an exact science and there is no one solution for any given situation. a range of options should be considered (and consulted on where required) to identify the best possible solution. designing for cycling is a creative challenge which requires designers to think through the consequences of their choices in the design rather than simply applying standard templates.
  - the aim is to find the best solution possible for cyclists – the aim when designing active travel routes is to make cycling on those routes more attractive than using motor vehicles. people must choose to cycle and will only do so if they gain from it personally.



- the existing motor traffic situation must be considered – This should be based on actual surveys and observations rather than just the speed limit or assumptions about street type. For example it should not be assumed that traffic speeds and volumes are low in all residential streets. Similarly a low speed does not automatically infer that cycle and motor traffic can be combined and in some situations segregation may be required despite low speeds. An approach which includes observations of actual use in addition to the considerations of intended use is necessary.
- speeds and volumes of motor traffic on any route are not fixed – Where necessary, consideration should be given to measures which could change the function of a street, including motor traffic volumes and/or speed in order to bring a route within acceptable standards. A major deterrent to cycling expressed by non-cyclists is fear of motor traffic (Carnall, 2000), and vehicle speed is a major factor in perceptions of the road environment as hostile by both cyclists and pedestrians.
  - » in relation to traffic volume, filtered permeability or the creation of vehicle restricted areas could be used to create a more attractive and safer cycling route.
  - » influencing the speed of traffic can be achieved through traffic calming and/or the introduction of 20mph limits and zones – see Chapter 4.
- junctions are a key area of concern – As noted in Chapter 4, a high proportion of collisions involving cyclists occur at junctions. Despite this, less consideration has often been given to the movements of cyclists through junctions than on links, which can leave cyclists feeling abandoned when they most need cycle-specific infrastructure. Active travel networks should in future ensure that there are no gaps in provision along any part of a route and that junctions are given particular attention. The following should be considered:
  - » speed reduction and legibility are crucial factors in improving safety for all users.
  - » junctions should be designed such that all users are aware of the potential positioning and movements of other users.
  - » visibility and eye contact are key as the ability to communicate between different road users improves safety.

- » greater priority should be given to cyclists wherever possible through raised tracks with priority at side roads, cycle specific signals, increased green time on cycle routes (particularly on uphill gradients), toucan crossings, and raised table junctions which reduce the speeds of all users to that similar to cyclists.
- » conventional roundabouts often pose the highest risk to cyclists
- designs should not be developed in a vacuum – the best designs, particularly for complex problems are often identified through brainstorming sessions involving user groups and designers.

#### 4. If The Route Cannot Be Improved to Required Standard - Reconsider Options

- 5.8.56 If, following steps 2 and 3, it is considered that no motor traffic management changes or physical measures are feasible which would bring the route up to the required standard, then the next most direct route should be assessed for suitability.
- 5.8.57 Another possibility may be that if the route could not feasibly be made suitable to be a primary cycle route, consideration could be given to downgrading it to a secondary or local route, if the appropriate standards could then be met. For example, cycle lanes that cater for single file cycling may be appropriate on a secondary route but a primary route would need lanes that allow for cycling side-by-side.

#### Stage 5: Validation

- 5.8.58 Once the draft integrated network maps have been produced, there should be broad engagement and consultation with both internal and external stakeholders in order to validate the proposals.
- 5.8.59 This consultation should be as extensive as possible to help ensure all those who may be affected by the proposals have a chance to input. For the integrated network maps developed as part of the Act it is recommended that there should be a 12 week public consultation.
- 5.8.60 General advice on consultation is included in Chapter 3 - a brief summary of the key points is provided below.
- local authorities should consult with all of the people who will be affected by the proposals including those who live in the vicinity of the routes and those who are likely to use them
  - it will be important to be clear in the public consultation that the integrated network maps show longer term aims.



- consultation on the maps will not replace the need for consultation and negotiation on individual schemes as and when specific proposals for delivery / implementation are taken forward.
- it will be important to engage with diverse groups including those who are not currently active travellers and those who are members of groups with protected characteristics under the Equalities Act 2010. An Equality Impact Assessment may be required (see Chapter 2).
- engagement should be carried out through a variety of means such as social media, online surveys, and exhibitions in public buildings and on-street consultation in town centre locations.
- local authorities need to consider the appropriate level of detail to be provided when consulting with the public and avoid engineering style drawings or technical jargon if possible.
- consultation should be seen as an opportunity to promote active travel and a means of engaging people in reconsidering their travel options.

### **Stage 6: Final Integrated Network Map**

- 5.8.61 Following consultation sufficient time and resources should be allocated to ensure any necessary amendments are made to the integrated network maps prior to submission to the Welsh Ministers for approval.
- 5.8.62 The Delivery Guidance gives detail guidance on the submission, approval and review process.

### **Stage 7: Prioritisation**

- 5.8.63 Local authorities should decide for themselves how best to plan for the delivery of their integrated network. However it is recommended that they focus on those parts of the network that are most likely to have the greatest impact on increasing rates of active travel and the number of people who choose to travel actively (Delivery Guidance 5.1.3.).
- 5.8.64 One of the key benefits of the identification of schemes within an integrated network map is the ability to deliver the network through a broader range of funding sources and not just through those budgets specific to active travel.

- 5.8.65 As well as costs and the availability of funding, prioritisation of schemes should also be informed to some extent by the deliverability of the schemes. It is likely that schemes identified in the integrated network maps will fall into one of the following categories:
- ‘Shovel Ready’ – schemes which are ready for immediate delivery or are under active development
  - medium term – schemes where there is a clear intention but delivery is dependant on funding availability or other issues
  - longer term – more aspirational schemes or those awaiting defined solution
- 5.8.66 When considering funding submissions the Welsh Ministers expect to see key schemes being prioritised, and evidence that the integrated network maps have been considered (Delivery Guidance 2.6.3).



## Key References

Aldred, R (2012) Cycling cultures: summary of key findings and recommendations. ESRC, UEL.

Bristol City Council (2012) '20mph speed limit pilot areas' - <http://www.bristol.gov.uk/page/20mph-speed-limit-pilot-areas> (Accessed 1st May 2012)

Bristol City Council (2012b) 20mph Speed Limit Pilot Areas - Monitoring Report (March 2012)

[http://www.bristol.gov.uk/sites/default/files/documents/transport\\_and\\_streets/managing\\_roads\\_and\\_traffic\\_schemes/20mphMonitoringReport6\\_3\\_12.pdf](http://www.bristol.gov.uk/sites/default/files/documents/transport_and_streets/managing_roads_and_traffic_schemes/20mphMonitoringReport6_3_12.pdf)

CROW (2007) Design Manual for Bicycle Traffic.

Carness, D (2000) Cycling and Health Promotion *BMJ* 2000;320:888

Department for Transport (2008) Cycle Infrastructure Design – LTN 2/08

Dutch Ministry of Water, Energy and Transport (2009) Cycling-Inclusive Policy Development: A Handbook

Warrington BC (2010) Executive Board 18 October 2010 (20mph Speed Limit Trial Assessment)

# 6 Designing for Walking and Cycling

This Chapter provides guidance on the design of active travel routes for walking and cycling. Section 2(6) of the Active Travel Act requires local authorities to have regard to this guidance when determining whether a route is suitable to be designated as an active travel route.

## 6.1. Introduction

- 6.1.1 This chapter provides advice on the design of active travel routes – links, junctions and crossings which meet the needs of pedestrians and cyclists, in urban and in rural situations.
- 6.1.2 It builds on guidance on the User Needs (Chapter 4) and on the Network Planning for walking and cycling (Chapter 5). It should also be read in conjunction with Chapter 8 on Related Facilities, which covers direction signing, cycle parking and features of value to pedestrians, such as benches, as well as Chapter 10 on Construction, Maintenance and Management, which includes details on drainage, fencing, tactile paving, lighting and access controls.
- 6.1.3 Appendix A provides more detailed design guidance on specific measures combining advice on key design features with other considerations, alongside a drawing for each of a series of Design Elements. Where the text refers to a Design Element in Appendix A it is noted with a reference, eg DE006.
- 6.1.4 Each Design Element has been given one of three statuses, defined as:



### Standard Details

Details that are well understood and should generally be applied as shown unless there are particular reasons for local variation.



### Suggested Details

Details that have not been widely applied in Wales but may be considered appropriate for use in the circumstances as advised.



### Possible Details

Details that are largely untested in Wales but have been used successfully in other places and may be considered for use in pilot schemes to gain further experience.



- 6.1.5 Within this document those elements denoted as Standard Details will be regarded as “standards” for the purposes of chapter 3(6)(a) of the Active Travel Act.
- 6.1.6 The use of advice categorised as Suggested Details or Possible Details will require careful monitoring by the local authorities who implement them. More details of the monitoring process can be found in Chapter 11. There will be no requirement for formal approval from Welsh Government to use Suggested or Possible details – the decision to introduce these layouts will be a matter for the individual Highway Authority.

## 6.2. General Considerations when Designing Routes

- 6.2.1 When designing active travel routes it is essential to recognise that:
- active travel routes need to connect with one another to form a coherent network (see Chapter 5).
  - the needs of all users need to be fully considered, including children and young people, older and disabled people, including people with vision, hearing, cognitive and mobility impairments (see Chapter 4).
  - the potential to reduce motor traffic speeds and volumes and the maximum size of vehicles along active travel routes should always be considered whenever such routes are being designed.
  - when upgrading a street to provide facilities for other road users this should not be to the detriment of existing pedestrians or cyclists.
  - opportunities should be taken to reallocate road space away from motor traffic to make conditions better for pedestrians and/or cyclists
  - allowing for the anticipated increase in use is important - the choice of design solution should take account of the ability of that solution to accommodate substantial increases in usage, and the cost of providing greater capacity should additional works prove necessary.
- 6.2.2 In order for active travel routes to be well designed and fit for purpose, a number of important factors must be taken into account:
- route characteristics and functions, both in terms of movement and place (see Manual for Streets)
  - expected level of use by pedestrians and cyclists
  - the type of cycle route (Primary, Secondary or Local – See Chapter 5)
  - motor traffic speeds, volumes and composition
  - the space available



- the need for kerbside activity, such as parking and loading
- construction, maintenance and enforcement requirements; and
- cost / funding.

### Coloured surfaces

- 6.2.3 Coloured surfaces are not prescribed by TSRGD and have no legal meaning. There is no obligation to use them and the value of doing so should be balanced with cost and requirement for maintenance. If they are poorly maintained they can make conditions worse for cycling.
- 6.2.4 For best effect coloured surfaces should be used sparingly, but it can be useful for emphasising cycle lane markings, helping cyclists to follow a route and to remind motorists that the surface is either primarily or exclusively for the use of cyclists. They can also help cyclists to follow a route or position themselves in the appropriate part of a carriageway.
- 6.2.5 Locations where properly maintained coloured surfacing may be appropriate for safety reasons are:
- advanced stop line reservoirs and their feeder lanes
  - across the mouth of junctions
  - through complex junctions
  - on cycle lanes alongside on-street car parking (in addition to the buffer strip)
  - any other areas of potential conflict
- 6.2.6 Selection of the appropriate colour is a matter solely for the relevant highway authority. However, where local authorities do not have a standard policy, it is recommended that red is used, which will over time become recognised as a consistent standard across Wales.

### Tactile paving

- 6.2.7 Tactile paving is provided on both links and at junctions and crossings to assist visually impaired people in moving around an area. The use of tactile paving should be considered at the design stage to ensure it is fully integrated. Adding tactile paving at a later stage could compromise the design, which can cause a reluctance to install tactile paving.
- 6.2.8 The types of tactile paving and their typical uses are described in detail in chapter 10 Construction, Maintenance and Management, as well as being shown in context on the Design Element diagrams.

## 6.3. General Design Approaches

6.3.1 The following design approaches have benefit to both pedestrians and cyclists and apply to both links and junctions.

- reallocation of road space
- reducing the speed and volume of motor vehicles
- filtered permeability
- Vehicle restricted areas
- home zones
- DIY streets
- shared space

## 6.4. Reallocation of road space

6.4.1 The reallocation of road space from motor vehicles to active travel modes makes an important statement about the relative priority of different transport users. It not only creates better conditions for walking and cycling but also makes a statement that active travel is considered to be at least as important as motorised travel. Typically this will involve one or more of the following:

- filtered permeability, e.g. road closures (with exemptions for pedestrians and cyclists)
- removal of one or more general traffic lanes
- reduced width of general traffic lanes
- removal of centre line
- removal or relocation of car parking
- shared space

6.4.2 Significant kerb line changes can have an impact upon existing drainage and utilities which may be costly, and early engagement with statutory undertakers is necessary. However, changes to kerb alignments will sometimes be necessary in order properly reallocate road space so that the needs of pedestrians and cyclists are met.

**Photo 6.1 - Reallocating carriageway space to cycling enabled this two-way segregated track to be created in Glasgow**



## 6.5. Reducing the Speed and Volume of Motor Vehicles

- 6.5.1 As noted in the introduction to Chapter 4, both pedestrians and cyclists will benefit from reducing the speed and volume of motor traffic along active travel routes, at both links and junctions. This will provide benefit in terms of safety, comfort and attractiveness, and will also reduce the difference in travel time between driving and active travel. There is a range of measures that can be used to achieve this, as shown in Table 6.1 overleaf.

**Table 6.1 - Techniques for Reducing Speed and Volume of Motor Vehicles**

Measure	Description
Filtered Permeability	This technique involves the ‘filtering out’ of motor vehicles (sometimes of only private traffic, with bus access being retained) from parts of a network. Cycling and walking permeability, i.e. providing a choice of routes through a network, is retained. If access for motor vehicles in one direction only is removed, cycling should be permitted in both directions (contraflow cycling).
20 mph limits and zones	Vehicle speeds are reduced, ideally with physical measures, to create a lower speed environment
Physical traffic calming	A range of options exist for reducing traffic speeds through physical measures, such as road humps and carriageway narrowing. Any traffic calming devices should be designed to be safe and comfortable for cyclists.
Changes in road geometry and layout	Manual for Streets provides guidance on how road geometry and layout can be used to reduce motor traffic speeds – such as reducing carriageway width, reducing forward visibility and using sharp changes in direction. Reallocating carriageway width to widen footways and/or to enable dedicated space for cycling will tend to reduce speeds and provide additional safety and comfort for active travel. Quiet Streets and Cycle Streets involve the introduction of features to the carriageway layout which show that the route is intended to be used as an important cycle route.
Home Zones and DIY Streets	Home Zones comprise residential streets in which the whole of the road space is shared between all road users, although it will often include a pedestrian-only space for vulnerable users. Design speed is set very low, at less than 20mph. Home zones enhance streets so that they are not just traffic routes but spaces for community activity. DIY Streets use a similar approach but in a low-cost way, with the design and implementation of the scheme being led by the local community.

Measure	Description
Quiet Lanes	Quiet Lanes are the rural equivalent of Home Zones. These are aimed at making country lanes more attractive for walking, cycling and horse riding.
Shared spaces	Shared Space schemes minimise the use of traffic signs/ markings and other traffic management features. The lack of a clear indication of priority encourages motorists to see the space as different from a typical road and to react by driving more slowly. In some cases there is no or low height kerbing or demarcation between the pedestrian-only space and the vehicle track, though a lack of delineation between the footway and the carriageway will impact on blind and partially sighted people. Shared spaces tend to be suited to central urban streets with high pedestrian usage.
Vehicle restricted areas	Vehicle restricted areas involve prohibiting vehicles from streets by type of vehicle and/or at certain periods during the day. For example service vehicles may be prohibited from a shopping street between the hours of 10:00 and 16:00. Even when vehicles are allowed to use the area, speeds are normally kept low through the use of appropriate techniques such as 20mph limits, traffic calming and shared space techniques.

## 6.6. Filtered Permeability

6.6.1 Filtered permeability provides an advantage to cycling and walking by exempting it from access restrictions applied to motor traffic; or through the creation of short connections only available to cyclists and pedestrians. Filtered permeability is often created by imposing Traffic Regulation Orders (TROs), typically:

- road closures
- point closures
- banned turns
- one way streets

6.6.2 There should be a presumption to exempt cyclists from any such TROs unless there are overriding safety reasons for not doing so, which could include an unacceptable impact on pedestrians.

6.6.3 Photo 6.2 shows how access to a side street has been provided for cycles only, similar to that shown on DE008.

**Photo 6.2 - Cycling exemption at road closure (Brighton)**

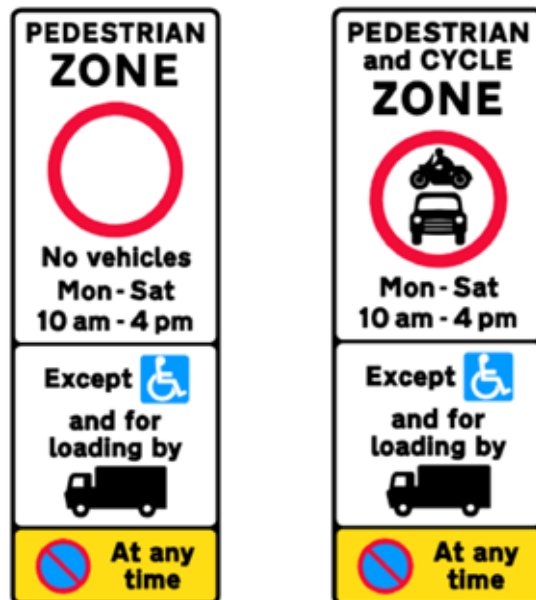




## 6.7. Vehicle Restricted Areas

6.7.1 Vehicle restricted areas (VRAs) are generally found in city/town centres where motor vehicles are restricted from using certain streets for some or all of the time, with these areas often referred to as 'pedestrianised'. The main purpose of VRAs is to provide an environment where pedestrians can move around freely without fear and intimidation from vehicles. They are marked by entrance signs which denote either 'Pedestrian Zone' or 'Pedestrian and Cycle Zone'\* as appropriate.

**Figure 6.1 - 'Pedestrian Zone' / 'Pedestrian and Cycle Zone' signage**



6.7.2 VRAs will usually be included in the network of active travel routes, whether only for walking, or for both walking and cycling. Because most VRAs are in urban centres, they usually serve important destinations and provide one or more direct routes between different parts of the town or city.

6.7.3 VRAs often have a level surface which enables pedestrians to use the whole of the area, which is particularly beneficial to people with mobility impairment including those using wheelchairs and mobility scooters. Some vehicular access will often be necessary at certain times, typically for servicing, and in some cases authorities may wish to allow access to car parking spaces for disabled people and for taxis and/or private vehicles in the evening to support the night-time economy. Depending on the type and volume of these movements, it may be necessary to denote a vehicle track through the street, but using kerbs to define the route will



restrict pedestrian movements and will suggest that vehicles have priority at the times they do have access. However, if kerbs are used, regular dropped kerb crossing points should be provided.

- 6.7.4 When deciding on the physical extent of the vehicle restrictions authorities should consider that large VRAs may present access problems for pedestrians, particularly older and disabled people, if they have to walk long distances from public transport stops or car and cycle parking. Allowing access to disabled car parking spaces within the VRA will improve accessibility for those with access to a car but will reduce pedestrian comfort.
- 6.7.5 Seating and other street furniture such as lighting units and litter bins will normally be required in VRAs. Convenient cycle parking will also be important, particularly for disabled cyclists with mobility impairment, who will need to park close to shops and other facilities. All street furniture should be located carefully so that it does not interfere with important pedestrian desire lines and the vehicle track. Street furniture should contrast with background materials to increase its visibility.
- 6.7.6 Allowing cycling in VRAs can cause concerns, particularly to disabled people with physical, sensory and cognitive impairments who may not expect cyclists to be present, and this issue can be therefore be contentious. However, serious consideration should always be given to allowing cycling through VRAs. These areas are often prime destinations where shops and services are located and so good access is important.
- 6.7.7 Research into the level of conflict between cyclists and pedestrians was carried out by TRL in the study 'Cycling in Vehicle Restricted Areas (2003). This study found that cyclists alter their behaviour according to the density of pedestrian traffic – as pedestrian flows rise, the incidence of cyclists choosing to dismount also rises and those cyclists who continue to ride do so at a lower speed.
- 6.7.8 Including cycling in the ban on vehicular traffic can create major barriers to cycle movements across urban centres, particularly if the VRAs are large. If cyclists are required to travel longer distances via more heavily trafficked routes around the VRA this will tend to suppress cycle trips and reduce cycle safety.



- 6.7.9 If cycling is not to be allowed within the VRA for all or part of the day the alternative routes that cyclists would need to take to complete all of the journeys affected by the restrictions should be assessed, based on the guidance in this document. In general, any alternative routes around the VRA should be of equivalent coherence, directness, safety, comfort and attractiveness and meet the minimum requirements for an active travel route.
- 6.7.10 If restrictions on cycling are considered necessary, they may only be required at certain times of day. Permitting cycling before 10 am and after 4 pm can meet the needs of commuter cyclists while avoiding the busiest periods of pedestrian activity. Providing a period when no cycling is allowed will also enable those people who wish to be certain of a vehicle-free space to gain access. Cycling should not be restricted during any times when motor vehicles are permitted.
- 6.7.11 Further guidance on the design of cycle routes through VRAs is given in Section 4.3 of Local Transport Note 2/08.

## 6.8. Home Zones and DIY Streets

### Home Zones

- 6.8.1 Home Zones comprise residential streets in which the whole of the road space is shared between all road users, although it will often include a pedestrian-only space for vulnerable users. Design speed is set very low, at less than 20mph and maximum motor traffic flows of 100 vehicles per hour are the norm.
- 6.8.2 Home Zones enhance streets so that they are not just traffic routes but spaces for community activity. This helps restore the balance between traffic and people. This in turn can help make streets safer, more sociable, and better places to live in.
- 6.8.3 Home Zones often involve design techniques such level surfaces, changes in material, trees and planting to change the whole environment, and can be legally designated under the Transport Act 2000. Further guidance on the design of Home Zones is given in the IHE Home Zone Design Guidelines.

## **DIY Streets**

- 6.8.4 DIY Streets is a Sustrans community-led initiative that works with residents, the highway authority and other partners to create high quality urban improvements that promote and facilitate sustainable travel. These projects help to facilitate residents to make their neighbourhoods safer and more pleasant places to live. They are an affordable, community-led alternative to the Home Zones design concept.

## **6.9. Shared space**

- 6.9.1 Shared space aims to reduce the dominance of motor vehicles by reducing traffic management features that tend to encourage motor vehicles to assume priority. It helps to create ambiguity and thus reduce traffic speeds. In the UK it has been primarily focused in town centres where there is likely to be a high proportion of pedestrians. While they have no legal status, evidence has shown that they can be effective in positively influencing road user behaviour. Careful design and monitoring is necessary to ensure that safety is maintained or improved.
- 6.9.2 The effect of shared space can greatly improve the public realm by reducing traffic speeds while encouraging drivers to be more accommodating towards pedestrians and cyclists. Well designed shared space can be attractive to cyclists however this can often increase interaction with pedestrians and reduce speeds. Guidance for England is published in LTN 1/11, the principles of which may be useful in Wales, and the National Federation of the Blind (2013) Access for Blind People in Towns.
- 6.9.3 A level surface is a particular form of shared space, where the street surface is not physically divided by kerb or level difference into areas for particular users, but these need careful design if they are to work for all users. Disabled people with physical, sensory and cognitive impairments all find such streets difficult to use and many avoid such areas. There needs to be a distinct, detectable route for vulnerable pedestrians, though this does not prevent other pedestrians who wish to from sharing the central part of the space. Currently the only confirmed demarcation is a footway raised above the carriageway with a kerb upstand.



## 6.10. Link Design

### Requirements for links

6.10.1 The basic function of a link, which is defined as a section of route between junctions, is to provide a connection between places. Of the five basic requirements set out in Chapters 4 and 5 the three most important for links are that they are:

- direct,
- safe and
- comfortable

6.10.2 Attractiveness also has a role.

### Direct

6.10.3 Pedestrians and cyclists require routes that follow natural desire lines and which avoid deviations. Where pedestrian routes are indirect many users will choose a shorter route if available, away from the formal footway or footpath. Routes for cyclists should be as least as direct as those for motor traffic.

6.10.4 Directness in terms of time is also important, and this is particularly an issue for cyclists as any delay due to having to slow down or stop imposes a substantial time penalty as well as wasted effort. Cycle tracks should be of adequate width for the expected flows to avoid undue delay resulting from speed variance amongst cyclists.

### Safe

6.10.5 The design of walking and cycling infrastructure must ensure through design that the risk of injury to pedestrians and cyclists is minimised. On links, attention should be given to the following:

- providing sufficient width for pedestrians so that they are not required to step into the paths of motor vehicles or cyclists due to crowding
- ensuring adequate geometry, visibility and surfacing to avoid cyclists running into the path of motor traffic or pedestrians, allowing for errors and evasive manoeuvres;
- minimising conflict between cyclists and pedestrians by either providing effective separation between them or by allowing sharing to take place where there is sufficient width and cycle speeds are not high.
- separating cyclists from motorised traffic;



- avoiding conflicts between cyclists and oncoming traffic (including other cyclists)
- ensuring that the design of any infrastructure for cyclists reflects how cyclists are trained through National Standards Cycle Training

### Comfortable

6.10.6 Walking and cycling infrastructure should facilitate people's travelling experience through minimising their exposure to nuisances such as:

- minimising the gradients along links and keeping any slopes as short as possible (see Chapter 4)
- providing smooth surface texture which is well maintained (see Chapter 10);
- avoiding placing any obstructions along a route and remove existing ones
- providing adequate width for the volume and type of pedestrian and cycle flows expected;
- minimising lost time for cyclists having to slow down or stop - for example at bus stops or poorly designed traffic calming
- minimising nuisance from motor traffic, through reduced speeds and greater separation;
- minimising any conflict between pedestrians and cyclists

### Attractive

6.10.7 Pedestrians and cyclists are much more exposed to their environment than people in motor vehicles, so a key element of link design is improving the quality of the experience when using a particular section of route. Routes should:

- look attractive and be interesting
- integrate with and complement their surroundings
- contribute to good urban design
- have good public security, be well overlooked and lit
- be well maintained

## 6.11. Segregation between Cyclists and Pedestrians DE023, DE024, DE032 and DE033

- 6.11.1 Where cyclists are routed onto off-carriageway tracks, through green spaces and on highways at both links and junctions, there will usually be a need to consider how they interact with pedestrians. There are two possible approaches to the design of routes where pedestrians and cyclists are using the same route, often referred to as 'shared use':
- segregated provision, where cyclists and pedestrians each have their own defined space; and
  - unsegregated provision, where cyclists and pedestrians share the space
- 6.11.2 Guidance on the design of shared use facilities is contained in the Department for Transport's Local Transport Note 1/12, Shared Use Routes for Pedestrians and Cyclists, although it should be noted that this has not formally been adopted in Wales.
- 6.11.3 Early consultation with relevant interested parties, such as those representing disabled people, walkers and cyclists, should be part of developing the design of a cycle track which interacts with pedestrians, including decisions on segregation. Designers are encouraged to think through their decisions rather than start from a default position of implementing any particular feature.
- 6.11.4 In general, separate provision for cycling will tend to provide a route where people are able to maintain their desired speed. This will be important on active travel routes, which are designed to provide for utility trips and to provide a realistic alternative to the car over short distances.
- 6.11.5 For a segregated path to operate effectively adequate width should be provided for each user group and segregation should be effective, as discussed below. Non-compliance with segregation, where and when it occurs, may lead to increased potential for conflict amongst all users. Where levels of non-compliance are likely to be high due to there being inadequate space for effective segregation, options will include:
- increasing the path width
  - providing an unsegregated track
  - providing an alternative route for cycling



6.11.6 Factors that will need to be taken into account when deciding whether a route should be segregated will include:

- pedestrian and cycle flow
- cycle speed
- cycle journey purpose
- visibility
- whether significant numbers of vulnerable users are expected – elderly, disabled, children
- available width/presence of pinch points e.g. bridges
- ‘exchange’ activity – shopping, playing etc.

6.11.7 The key pros and cons of each type of provision are given below.

**Advantages of effective segregation include:**

- cyclists can maintain a higher speed
- helps cyclists to pass pedestrians engaged on ‘exchange’ activities – e.g. playing, shopping
- more comfortable for pedestrians who may not expect the presence of cyclists
- less intimidation for vulnerable pedestrians, particularly the visually impaired
- reduced perception of conflict by both groups
- keeps cyclists away from driveways as the cycle track is usually located next to the carriageway

**Disadvantages of segregation include:**

- segregated routes can encourage territorial behaviour which can raise conflict if the segregation is ineffective.
- where pedestrians walk in groups (especially at weekends and school journeys) they are more likely to ignore segregation unless widths are adequate
- can be more costly to provide, and require more land availability

**Advantages of unsegregated routes include:**

- unsegregated routes are more flexible – for example, cyclists may be the majority group during the weekday peak, and pedestrians in groups during weekends.
- unsegregated routes with a single surface are better able to accommodate larger cycles, such as those used by disabled people, and people in wheelchairs
- unsegregated routes may be cheaper to construct and maintain due to less complex engineering and a narrower width. (Construction costs can be up to three times higher if segregation by kerb is used).
- in many cases unsegregated routes require fewer signs and markings, thereby offering a less urban and intrusive solution.
- can be a useful way of accommodating many different movement types especially at crossings, bus stops and complex junctions

**Disadvantages of unsegregated routes include:**

- potentially intimidating for pedestrians, particularly visually impaired people, and especially with high volumes of cyclists.
- can be frustrating for cyclists who have to limit their speed to accommodate pedestrians

**Type of segregation**

- 6.11.8 Good compliance with segregation will not be achieved at all times unless adequate width is provided for each user group and the means of segregation is effective.
- 6.11.9 Segregation should normally be achieved using design features such as contrasting materials, a change in levels or a grass verge (see Photo 6.3). Material choices that give a good tonal contrast will help all users to understand the separation between types of user, and particularly valuable for visually impaired pedestrians. Typically this might involve using asphalt for cyclists and light coloured pavements for pedestrians.
- 6.11.10 Segregation using only simple white lines (Diag 1049) (which are not detectable by blind users) or a raised white line delineator (Diag 1049.1) is an option, but it is rarely respected by pedestrians, unless cycle flows are high or there is generous width, and should not normally be used.

**Photo 6.3 – Segregated footway and cycle track at Southend, using contrasting colour and a flush kerb to separate pedestrians and cyclists**



### **Monitoring and Management**

- 6.11.11 Following the introduction of any facility where cyclists are routed alongside or with pedestrians, it is advisable to monitor its performance including, where practicable, engagement with potential users who may not use the path because of its design. This will enable any concerns to be identified early on and suitable mitigating measures implemented if required (see also Chapter 11).

### **6.12. Pedestrians on Links – DE001, DE002, DE003 and DE004**

- 6.12.1 Provision for pedestrians will vary depending on the characteristics of the surrounding environment and the nature of the route. Most routes will be on footways adjacent to carriageways. Other walking routes will generally be along footpaths away from roads, such as paths through housing estates, parks and alongside waterways (DE2). Where footways or footpaths are being designed as a shared use path for pedestrians and cyclists (segregated or unsegregated) refer to Section 6.11 and DEs 023, 024, 032 and 033.



- 6.12.2 In order to be attractive to pedestrians walking routes should follow desire lines as closely as possible. Walking routes should be designed with sufficient widths and to minimise the need for changes of grade, whilst remaining close to the desire lines. All changes of grade should be designed to be accessible to all users.

### Widths

- 6.12.3 The width of a footway or footpath will need to be assessed taking account of the pedestrian flow, local land use and activity and the composition and the adjacent vehicle speeds and flows.
- 6.12.4 Basic minimum widths are given in Chapter 4 and are summarised on DE001 and DE002, but where pedestrian flows are high, for example at significant trip generators such as schools and retail centres, a detailed assessment of pedestrian capacity and comfort should be made (see TfL Pedestrian Comfort Guidelines, summarised in Chapter 4). Where there are high numbers of static pedestrian activities such as photography near tourist attractions, additional space for moving pedestrians will be needed.
- 6.12.5 Where a footway is adjacent to a road with high vehicle speeds or a high proportion of HGVs consideration should be given to providing a margin to separate the footway from the road, or to providing additional footway width. Footway widths may be increased by reallocating road space away from motor vehicles to pedestrians or increasing the usable footway width by removing or rationalising street clutter pavement and parking.
- 6.12.6 Well designed, functional street furniture is a vital part of the daily operations of the street environment. However, poorly designed and poorly placed street furniture can quickly develop into street clutter which can be hazardous (particularly for the visually impaired) and ruins the aesthetics of the street environment. Footways should be free of obstructions, with unnecessary street furniture being removed and the remainder located in a street furniture zone out of the main pedestrian flow. Items such as litter bins and other potential obstructions should have a minimum height of 1m and be continuous to the ground avoiding projecting bins sited on posts. DE1 provides guidance on the need for hazard protection to isolated objects.

**Photo 6.4 - Street clutter obstructing and narrowing the cycle track**



6.12.7 In Wales footway parking is not generally prohibited, but local authorities can prohibit footway parking through a Traffic Regulation Order.

6.12.8 Alternatively, it is possible to deter footway parking through physical measures, such as by installing bollards, raised planters or other street furniture, and by clearly indicating where people should park. These features will need to be well designed and located so that they themselves do not pose a problem.

### **Build-outs**

6.12.9 Build-outs can be used to locally widen a footway into the carriageway to provide additional footway width at particular features such as bus stops. They can also be used to restrict the carriageway width in order to calm traffic.

6.12.10 Build-outs may be provided at pedestrian crossing points to reduce the crossing width and to enable pedestrians to wait to cross in a more visible position. In all cases, for controlled crossings, tactile paving to indicate the crossing to blind and partially sighted people should extend back to the building line.

- 6.12.11 Build-outs can have a negative impact on cyclists, particularly if the remaining traffic lane would be in the critical width as defined in Section 4.17. Where pinch points are used, consideration should be given to the provision of cycle bypasses, as shown on DE007.
- 6.12.12 The angle of taper for a build-out needs to take account of the likely approach speeds of traffic. Where there is a likelihood of cyclists using the road and there are no cycle bypasses, the effect of a build-out on cyclists needs to be considered so that it does not force a cyclist out into the path of other vehicles, and should be no greater than 1 in 10.
- 6.12.13 It is essential that a build-out is conspicuous in both daylight and darkness. This may be achieved by positioning a reflective or illuminated bollard or other feature on the facing corner of a build-out.

#### Gradients, Ramps and Steps

- 6.12.14 The longitudinal profile of a footway adjacent to a carriageway should generally follow its vertical alignment, although there may be situations where a footway can usefully be maintained on a steady vertical profile while the carriageway goes through a sharp dip or crest. In these situations a retaining wall or slope between the carriageway and the footway will be necessary.
- 6.12.15 The gradients of footways and footpaths should accord where with the guidance given in Chapter 4 and summarised on DE001 and DE002.
- 6.12.16 Ramps and steps are provided to facilitate a change in level or grade on a walking route but should only be used where a sharp change in level or grade cannot be avoided. Guidance on the design of ramps and steps are given on DE003 and DE004.
- 6.12.17 Steps should usually only be provided in conjunction with a ramp in order to retain accessibility for mobility impaired pedestrians. Steps can provide a useful shortcut to maintain desire lines where it is necessary to also provide a ramp to accommodate a change in level or grade. Steps should be well designed with highlighted nosings/edges and handrails to both sides, incorporating corduroy warning paving to the top and bottom, and visual contrast between elements should be used to highlight features such as steps, edges and handrails.
- 6.12.18 The suitability of any existing steps on active travel routes should be assessed against DE4, with improvements made where necessary. The provision of wheeling ramps for cycles on steps is discussed in Section 6.51.

## 6.13. Cycling on Links - Introduction

- 6.13.1 The starting point for the designing of links for cycling on active travel routes is given in Table 6.2, which relates minimum provision to cycle route type, motor traffic volume and speed.
- 6.13.2 This shows how these factors influence the decision on the need to segregate cyclists from motorised traffic, and demonstrates how restraint of traffic speeds and volumes can be used to create satisfactory conditions, capable of encouraging new and novice cyclists to use the route.

**Table 6.2 - Preferred Minimum Provision - Cycle Links**

Speed Limit	Number of motor traffic lanes	Motor traffic flow (AADT)	Preferred Minimum Provision by Cycle Route Type	
			Secondary cycle route	Primary cycle route
20 mph	Irrelevant	1-2500	Quiet Streets: combined traffic	Cycle Streets or Quiet Streets: combined traffic
		2000-5000		Cycle Lanes
		> 4000	Cycle Lanes	
30mph	2 lanes in total	0-5000		
		> 4000		
	More than two lanes	Irrelevant	Cycle tracks	
40mph and over	Irrelevant		Cycle tracks (excluding light segregation and hybrid tracks)	

**Notes on Table 6.2:**

- this table does not include the Basic Network or cycle tracks away from highways
- designers should always consider the potential to reduce motor traffic speed and volume to create acceptable conditions
- there is some overlap between motor traffic flow ranges to allow for flexibility
- speed means speed limit, but if actual speeds are significantly higher, consider next highest category of speed
- cycle tracks includes light segregation and hybrid tracks unless noted
- in rural areas achieving speeds of 20mph may be difficult, and so shared routes with speeds of up to 30mph will be acceptable, with motor vehicle flows of up to 1000 vehicles per day

- 6.13.3 In practice, a cycle route from one place to another will often involve sections of different types of provision: shared roads, cycle lanes, cycle tracks alongside the carriageway and cycle tracks away from the road. A safe and convenient transition between these different forms of provision is critical to ensure route coherence.
- 6.13.4 Cycle routes away from roads generally offer important additional links in the cycle network and can provide very high quality routes. The decision to provide these should be based on wider network considerations, looking for opportunities to create links through green spaces, along waterways and other types of environment.
- 6.13.5 Most cycle links will be provided along highways, and in deciding the appropriate form of provision consideration must be given to the following requirements, constraints and issues:
- physical dimensions of the highway, including available widths and gradients
  - cycle demand (including the type(s) of cycle users, the type of cycle route and the current and forecast volumes of cyclists)
  - adaptability of the design to accommodate future growth
  - pedestrian demands and provision
  - motor traffic speeds
  - motor traffic volumes, including the volume of HGVs
  - interface with adjoining sections of route
  - the type and arrangement of junctions, including the frequency of minor arm junctions, intervisibility with conflicting traffic, and the potential to provide cycle priority;
  - conflicting uses, such as bus stops, loading and parking
  - place functions and visual character
- 6.13.6 Full consideration should be given to options for the suitable provision for cyclists on the carriageway or in a separate space for cycling – either through motor traffic speed / volume reduction, junction treatment and reallocation of carriageway space – before considering taking space away from pedestrians to create cycle tracks or shared use paths.

- 6.13.7 Where it is necessary to create separate provision for cyclists within highways, segregation from motor traffic can take a number of forms:
- separation by time – using traffic signals to separate cycle movements from motor traffic streams
  - light segregation - Intermittent physical separation from motor vehicles (e.g. use of refuges, planters, bollards, or other features)
  - continuous physical separation that can be crossed by cyclists (e.g. low kerb)
  - continuous physical separation that can only be crossed at designated locations (e.g. full height kerb, verge)

## 6.14. General Traffic Lane Widths and Car Parking

6.14.1 Designers will often need to consider the widths of general traffic lanes and parking spaces when designing active travel routes. In order to make separate provision for cycling, the reallocation of road space may be necessary (see Section 6.4 above). Designers will therefore need to assess the minimum width requirements of moving and stationary vehicles. When cyclists are sharing the carriageway, designers will need to consider how lane widths relate to the recommended positioning of cyclists (see Section 4.16).

### Lane Widths

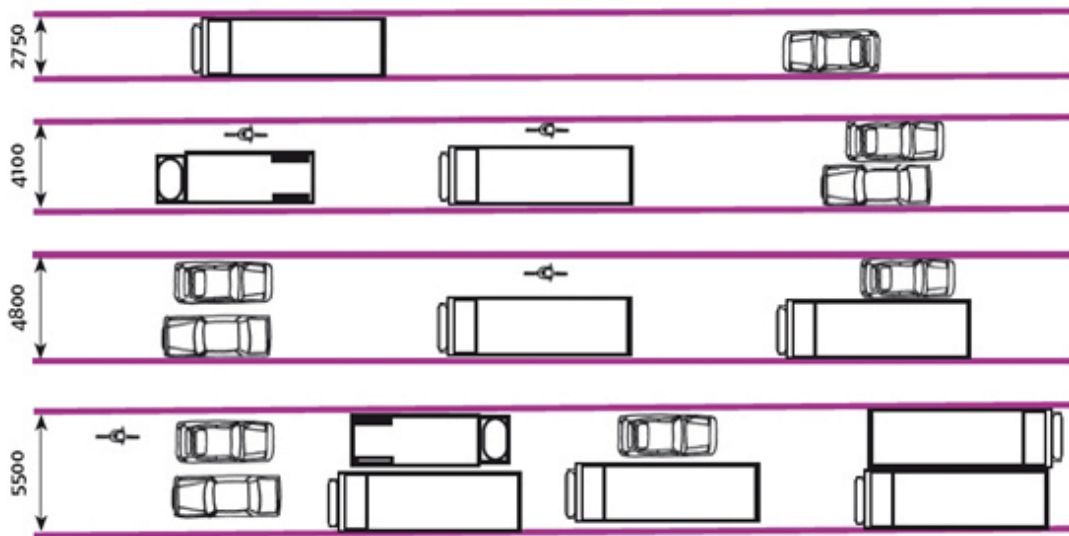
6.14.2 Figure 6.2, taken from Manual for Streets provides an indication of what various carriageway widths can accommodate and Figure 6.3, taken from the Cardiff Cycling Design Guide provides guidance on the size of vehicles that various traffic lane widths can accommodate; widths pertaining to trunk roads are given in TD27, although it should be noted that TD50 permits lane widths as narrow as 2.25m in certain circumstances on the approaches to traffic signal stop lines. Further guidance on traffic lane widths is given in Manual for Streets 2.

B

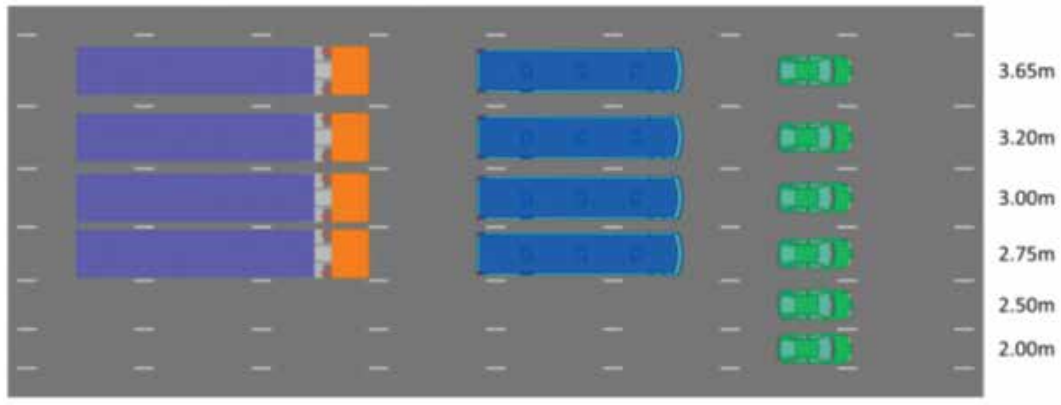




**Figure 6.2 - Illustration of what various carriageway widths can accommodate (from Manual for Streets)**



**Figure 6.3 - Vehicles and Lane Widths (from Cardiff Cycling Design Guide)**



- 6.14.3 Whilst traffic lane widths of 3.65m (metrication of 12 feet) have often been provided as standard in the United Kingdom, lane widths of 3.0 metres have been used in many parts of the country on urban roads for some time, and can accommodate most typical vehicles (including HGVs) at speeds up to 40mph (Transport and the Urban Environment, IHT 1997).
- 6.14.4 Where flows of large vehicles are low, and speeds are modest (less than 35mph), lane widths as narrow as 2.75m can accommodate car traffic comfortably. Larger vehicles can pass each other at this width at lower speed with care, although some drivers may choose to encroach slightly outside of lanes to pass (i.e. into an advisory cycle lane).



6.14.5 Where general lane widths exceed these values, designers should take the opportunity to reallocate space to walking and/or cycling. Where lane widths are in the critical range of 3.2m to 3.9m given in Chapter 4, conditions will be unsuitable for cycling on the carriageway unless traffic speeds and volumes are low so that drivers can cross easily into the opposing lane to pass a cyclist comfortably.

### **Car parking**

6.14.6 Parked vehicles also require physical width. Whilst the standard width of 2.4m for a car parking space is considered to be ideal, in practice it is recognised that this will often be difficult to accommodate within many existing streets. A width of 2.0m is the preferred minimum – this provides a margin of error to allow for poorly parked vehicles. Widths between 1.8m and 2.0m are only recommended if providing parking is essential and space constraints require such narrow widths.

6.14.7 Cyclists who have received training are taught to ride well clear of parked cars to avoid collisions with opening car doors, and cycle lanes should be separated from car parking by a buffer zone for that reason – see DE015 below.

### **6.15. Cycling on Links: Cycling in combined traffic**

6.15.1 There will be many streets where motor traffic volumes and speeds are sufficiently low to enable cyclists to share the road space with other traffic without the need for cycle-specific infrastructure. Table 6.2 gives the basic criteria for assessing whether conditions are suitable for different types of cycle route.

6.15.2 In designing such routes it is important not to assume that cyclists can simply ride with traffic, but to ensure that the layout of the street genuinely meets cyclists' requirements – in particular that the width of the carriageway meets the guidance given in Section 6.2 above.

### **6.16. Reducing Traffic Volumes and Speeds DE005, DE006, DE007**

6.16.1 Where traffic volumes and speeds exceed the values given in Table 6.2 consideration should be given to the potential to reduce traffic flows and speeds to appropriate levels so that cycling can be accommodated on the carriageway. Table 6.1 provides a list of suitable techniques - guidance on filtered permeability has been given in Section 6.6 above.



## 6.17. Contraflow Cycling DE009 and DE010

- 6.17.1 One-way streets and systems are very commonplace, having been installed for various reasons – to increase the overall capacity of a network, to ease motor traffic movements in narrow streets, increase residential parking capacity and to prevent through traffic for environmental and safety reasons. One-way streets significantly reduce the quality of the cycling network, which becomes less cohesive, less direct, less comfortable, less safe and less attractive. They may also risk inciting cyclists to travel illegally against the flow of traffic.
- 6.17.2 The permeability of the road network for cyclists can be greatly enhanced by exempting them from one-way restrictions, thus providing connections only available to cyclists. Two-way cycling should always be considered as the preferred option wherever it is proposed to introduce one-way working for general traffic. The operation of existing one-way streets should be reviewed with a view to permitting two-way cycling wherever safe and practicable. Scheme design should include consideration of the possible impact on pedestrians of all abilities and the ease with which they can understand that cyclists will be travelling in both directions.

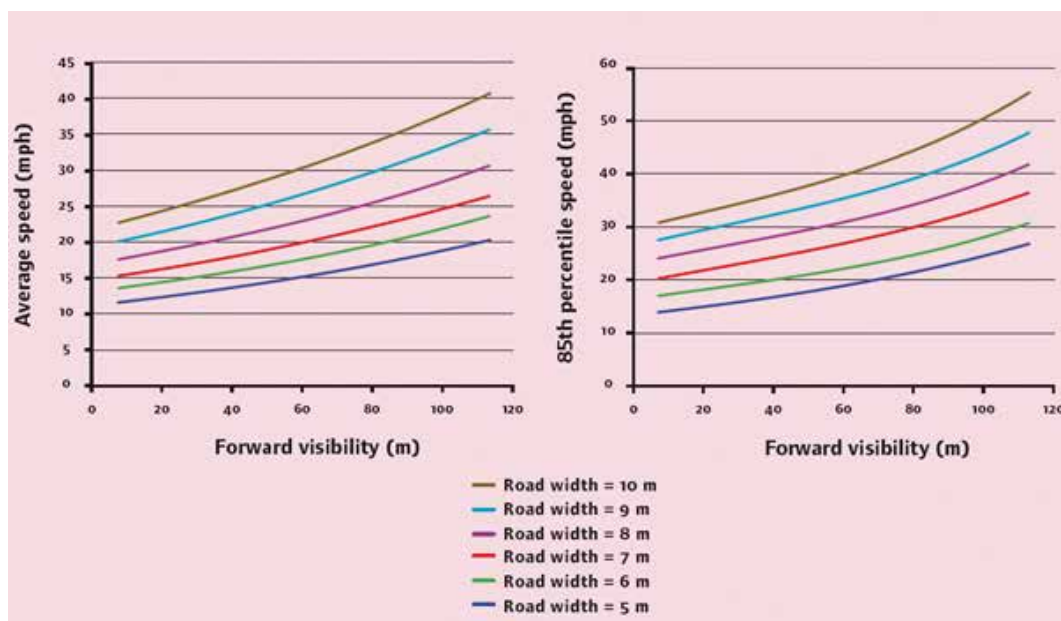
**Photo 6.5 - Contraflow cycling in a narrow street with no marked lane – Brighton**



## 6.18. Traffic Calming DE005, DE006 and DE007

- 6.18.1 Physical traffic calming measures are used to reduce motor vehicle speeds thereby improving safety for pedestrians and cyclists as well as improving living conditions for residents living along traffic calmed routes. Decisions on whether and how to implement traffic calming must take account of the requirements of the emergency services and of bus operators.
- 6.18.2 Traffic calming can significantly improve cycling conditions by reducing motor traffic speeds, but poorly designed vertical features can be uncomfortable for cyclists and horizontal deflections and pinch points can be intimidating.
- 6.18.3 Sinusoidal humps are much more comfortable for cyclists – see DE006 for details. Where pinch points are used, cycle bypasses should be provided – see DE007.
- 6.18.4 Speeds can also be reduced without overt traffic calming by changes in basic road geometry, such as using narrower carriageways, reducing forward visibility and using sharp changes in direction or vehicular priority.

**Figure 6.4 - The relationship between carriageway widths, forward visibility and speed, from Manual for Streets**



## 6.19. Quiet Streets DE011

- 6.19.1 Quiet Streets is a term given to urban cycling routes on low traffic speed and volume back streets, which are particularly suitable for new and less confident cyclists. Routes should maintain continuity for cycling and tackle physical barriers such as busy junctions without adequate cycle facilities, narrow paths, and should minimise diversions away from desire lines.
- 6.19.2 Cycle symbols to Diagram 1057 can be used to sign the continuity of cycle routes and indicate the correct positioning for cycling within the carriageway; in doing so they also raise motorist's awareness of cyclists, encouraging them to give cyclists space.

## 6.20. Cycle Streets DE012

- 6.20.1 A Cycle Street is a Quiet Street which also serves as a Primary Cycle Route. It should carry low volumes of motor traffic, high volumes of cycling, and provide cyclists with a level of service comparable to that provided by a high quality traffic free route.
- 6.20.2 The objectives of a Cycle Street are to:
- present a legible design recognisable to all types of user as a main cycle route
  - influence behaviour so that cyclists assume priority with drivers of motor vehicles behaving as 'guests', travelling at low speeds
  - maintain priority for cyclists, so that drivers do not overtake them
  - attract experienced cyclists as well as less confident cyclists

**Photo 6.6 – Cycle Street on Jack Straws Lane, Oxford**



6.20.3 In the consultation document which accompanied the draft amendments to TSRGD, the Department for Transport indicated that Cycle Streets could be subject to:

- a ban on motor vehicles overtaking cyclists
- an advisory speed limit of 15mph

6.20.4 Signs and orders to support these restrictions would require authorisation from Welsh Ministers and authorities who wish to trial such measures should seek advice from Welsh Government.

## 6.21. Cycle lanes DE009, DE013, DE014, DE015, DE016 and DE017

6.21.1 Cycle lanes are lanes on the carriageway that are reserved either exclusively or primarily for the passage of cyclists. Table 6.2 gives guidance on the conditions when cycle lanes are suitable on active travel routes.

6.21.2 Cycle lanes are normally located on the left or kerb side of the road and benefit from being included within the normal road maintenance programme. Because they are part of the main carriageway;

- the design of cycle lanes requires careful attention to turning movements of both cyclists and other traffic
- cyclists are not physically protected, and it is important that the traffic regime is appropriate to the presence of cyclists on the road
- they are only useful when clear of car parking and loading activity – cycle lanes should be preserved for the use of cyclists by the appropriate use of parking and loading restrictions. Careful attention to this design issue is required especially in town centres and around schools

6.21.3 There are two types of cycle lane: mandatory lanes are marked with a continuous white line supported by a Traffic Regulation Order (see Chapter 9), which prohibits motor vehicles from driving or parking in them during the hours of operation. There can be exceptions, such as for emergency service vehicles and access to private driveways.

6.21.4 Advisory lanes are marked with a broken white line which indicates that other moving vehicles should not enter unless it is safe to do so.

6.21.5 Where there are particular problems of overrun of cycle lanes by motor vehicles, raised thermoplastic markings can be used to help deter this.

- 6.21.6 Mandatory lanes provide greater protection for cyclists and should be used where possible. Mandatory lanes should operate at all times unless there are clearly justified reasons not to do so.
- 6.22. Car parking / loading and Cycle Lanes DE015**
- 6.22.1 Kerbside vehicle parking or loading can often be dangerous for cyclists especially in a street with high vehicle turnover rates as there is a high risk of vehicle doors being opened into the path of cyclists within the cycle lane. It is therefore necessary that any cycle lane must pass parking areas with a sufficient dividing strip (buffer zone) or else be of sufficient width to enable cyclists to travel in the cycle lane away from the parking.
- 6.23. Cycle Lanes at Side Roads DE016**
- 6.23.1 Cycle lanes should be continued across side road junctions to ensure continuity and help improve cycle safety. This can be achieved using a stretch of advisory lane, where the white line is broken, as continuous mandatory cycle lanes across side road junctions are not permitted. Under the forthcoming revision to the TSRGD it will be possible to use a road marking to diagram 1010 for this purpose (1m line, 1m gap). This is a more prominent marking than an advisory lane and is preferred.
- 6.23.2 It is recommended that cycle lane width be increased at side roads to encourage cyclists to position themselves further out from the kerb so that they can avoid vehicles nosing into the main road, and be more visible to drivers. A side road entry treatment should also be considered as this will reduce the speed of vehicles turning into and out of the junction.
- 6.24. Removal of centre lines DE017**
- 6.24.1 The removal of centrelines is a useful option where carriageway widths do not otherwise permit the introduction of cycle lanes of adequate width.
- 6.24.2 In addition to increasing the width available for cyclists, the technique also has a speed reducing effect as motor traffic no longer has defined lanes in each direction. Where the need arises for on-coming motor vehicles to pass each other, this is achieved by both vehicles momentarily pulling over into their respective near-side advisory cycle lanes, having first checked to see they are clear of cyclists.



**Photo 6.7 Cathays Terrace, Cardiff – Centreline removed to allow advisory cycle lanes to be introduced**



## 6.25. Cycle lanes with light segregation DE018, DE019, DE020

- 6.25.1 The segregation provided by a cycle lane along the side of a road may be reinforced by “light segregation” from the main carriageway, by using intermittent low level physical features such as planters, wands (retroreflective collapsible bollards), proprietary raised features constructed from PVC or recycled rubber, or similar objects. The fact that the obstacles are intermittent allows cyclists to manoeuvre between the cycle track and the carriageway as necessary, avoids any impact on drainage and means that the design can be cost effective and flexible.
- 6.25.2 Transport for London (TfL) and several other local authorities are starting to incorporate this style of facility into parts of their cycle networks and a scheme has already been successfully introduced in Royal College Street, in Camden. Light segregation is commonly used in various cities including Barcelona, Seville and, New York, Montreal and Melbourne.
- 6.25.3 These features are not road markings and therefore no authorisation is needed from Welsh Ministers in order to use them.



**Photo 6.8 – Light Segregated Cycle Lane, Royal College Street, Camden  
(Note: lane marking should be on outside of raised features)**



**Photo 6.9 – Light segregated cycle track with wand at start, Salford,  
Greater Manchester (Note – only one lane marking, outside the raised  
features, should be used).**



B

## 6.26. Hybrid Cycle Tracks DE021 and DE022

- 6.26.1 Hybrid cycle tracks have a cycle facility raised slightly above the carriageway surface but sitting below the level of the footway. This type of solution is common in Copenhagen and elsewhere on the Continent, and it has been used at a small number of locations in the UK, most notably on Old Shoreham Road in Brighton. Hybrid Cycle Tracks are referenced in Local Transport Note 1/12 Shared Use Routes for Pedestrians and Cyclists.
- 6.26.2 The positioning of the track immediately next to the main carriageway means that transitions between a cycle lane and a hybrid cycle track (and vice versa) are very simple and comfortable for the user.

**Photo 6.10 Hybrid Cycle Track – Old Shoreham Road, Brighton**





## 6.27. Cycle Tracks Alongside The Carriageway DE023 and DE024

- 6.27.1 Where traffic volumes and / or speeds are above the thresholds indicated in Table 6.2 physical separation from motor traffic will be appropriate to provide cyclists with safe and comfortable space, through the provision of segregated cycle tracks.
- 6.27.2 Cycle tracks should be of adequate width, comfortable, continuous and link into surrounding cycling infrastructure. Preferably they will be provided through reallocation of road space from the carriageway; in most urban locations the conversion of footways to shared use should be the last resort.
- 6.27.3 Cycle tracks away from roads are dealt with in Section 6.30 below.
- 6.27.4 Cycle tracks alongside the carriageway can be either be two-way or one-way. Two-way tracks are usually provided only on one side of the road, but provision on both sides is useful when it is difficult for cyclists to cross major highways. One-way tracks are usually provided on both sides of the road, with cyclists travelling in the same direction as other traffic.
- 6.27.5 Historically most cycle tracks in the UK have been built as two-way, but this can create a number of difficulties for users:
- retaining priority over side roads / busy accesses is more difficult
  - greater conflict with vehicles at private accesses
  - complexity of design of crossings at traffic signal junctions and roundabouts
  - difficulty of linking with adjoining cycle network at each end of the scheme
  - poor accessibility to development along the route on the opposite side
  - conflict with pedestrians crossing the carriageway
- 6.27.6 One-way cycle tracks on each side of the road address most of the above issues.
- 6.27.7 Cycle tracks may either be segregated from pedestrians, or may be shared with them with no differentiation of space. Issues to be considered in deciding whether segregation is appropriate are covered in Section 6.11.
- 6.27.8 The recommended widths for two-way cycle tracks, whether segregated from pedestrians or shared, are the same as those included in the section on cycle tracks away from the road, including the extra width required where there are edge constraints.

## 6.28. Cycle track crossing of side roads DE025 DE026

- 6.28.1 Uncontrolled cycle track crossings at side roads should, wherever safe and practicable, give priority to cyclists crossing the side road. Crossings that give cyclists priority over vehicles on the side road will allow cyclists to continue without loss of momentum and present a strong promotional message about how non-motorised users are valued along a corridor.
- 6.28.2 Priority crossings may not be appropriate in all locations, and where the cyclist is expected to give way clear road markings may be necessary.
- 6.28.3 Factors to be considered when determining who has priority include: location, vehicle speed, visibility, number of pedestrian and cycle movements, number of vehicle movements and accident statistics and the feasibility of providing similar priority at nearby side road crossings.

**Photo 6.11 – Priority crossing of cycle track over side road, Bristol**



## 6.29. Cycle tracks in centre of carriageway DE027

6.29.1 An option which has been little used in the UK at present is to place two-way cycle tracks in the centre of single carriageway streets, or one way tracks alongside central reservations. This can provide a very good facility for cycling along busy highways, which is clear of obstructions such as bus stops and side roads. Providing good access to and from the central track is critical, which is typically achieved via crossings or suitably designed junctions, and dealing with any conflicts at major junctions along the route. It may be necessary to ban turns across the central track at side roads, if it is not possible to create a suitable junction arrangement. Providing regular pedestrian crossing facilities that are accessible to all people will also be necessary.

**Photo 6.12 - Raised two way central track, Nantes (France)**



**Photo 6.13 - One way cycle track in central reservation, New York City**



## 6.30. Cycle Lanes/Tracks at Bus Stops DE028 DE029 DE030 DE031

- 6.30.1 Bus stops can pose a difficulty for people using cycle lanes and cycle tracks adjacent to the carriageway – moving past a stationary bus will either involve passing the bus on the off-side, with potential conflict with buses entering / leaving the bus stop or passing traffic, or on the footway side, with potential obstructions by street furniture and conflict with waiting / alighting pedestrians associated with the bus stop.
- 6.30.2 There is no standard layout for cycle lanes / tracks at bus stops that can address all considerations and there are a wide range of possible layouts. Each site will need considering on its own merits, and the following points require particular consideration:
- available space for cyclists to pass a stationary bus should be provided wherever possible so that momentum is maintained
  - the bus stop should be apparent to cyclists, who will need to be able to adjust their behaviour and speed to reflect the additional risk of conflict with buses or pedestrians



- there will need to be somewhere for pedestrians to wait where they do not pose an obstruction to any cycle bypass
- there should be good intervisibility between pedestrians (those waiting for a bus as well as those passing) and cyclists, to minimise potential for conflict

6.30.3 Five possible options are covered on the Design Elements sheets for minimising conflict with pedestrians and buses, which are:

- cycle lane terminates at bus cage, with alternative route past stop highlighted
- cycle lane continues around bus stop, possibly in conjunction with a bus bay
- cycle track bypass to rear of bus stop
- cycle lane / track runs across bus boarder
- a shared use area at the bus stop, with cyclists giving informal priority to pedestrians

**Photo 6.14 – Bus Stop Bypass, Brighton**



## 6.31. Cycle Tracks away from Roads DE032 and DE033

- 6.31.1 Routes free from motorised traffic (often referred to as traffic-free routes or Greenways) can be developed in urban, urban fringe and rural areas, utilising a wide range of linear corridors. Developing routes that provide direct connections between journey attractors, and which maximise connectivity to other parts of the networks, are key to achieving high usage.
- 6.31.2 Generally these will be cycle tracks either with an adjacent pedestrian route or else designed for unsegregated shared use where pedestrians and cyclists share the same path; guidance on the segregation of cyclists and pedestrians is given in Section 6.11 above.
- 6.31.3 Key features of successful traffic-free routes include
- routes should be direct and follow desire lines wherever possible, while avoiding steep gradients;
  - route capacity and widths should be designed for peak forecast demand conditions
  - minimum visibility and corner radii should be maintained, based on the appropriate design speed.
  - good quality surface materials should be provided
- 6.31.4 Common examples of features which undermine otherwise good off-carriageway routes include restrictive access controls, vegetation growth that encroaches on the track width, poor or inadequate lighting or failure of the track surface after winter conditions.
- 6.31.5 Where routes have existing equestrian usage their needs should also be considered. They should not be disadvantaged by the provision of active travel routes. Equestrians should not be denied access to routes that they currently have the right to use by changing the classification of the rights of way. There needs to be clear signing of which routes are intended for use by equestrians.
- 6.31.6 Successful cycle tracks away from the road require proper consideration of each element of the design and construction process. These are:
- Design**
- understanding the role of the route within the wider network
  - understanding the types and future volumes of users
  - track width

- track alignment
- gradients
- **Construction**
- formation and sub-base
- surfaces
- edges and verges
- drainage
- lighting
- ancillary works

### **Corridors for Traffic Free Routes**

6.31.7 Traffic free routes come in a wide variety of forms, and a popular route may comprise one or several types that link to create a coherent corridor. The most common types of corridors used as traffic free routes are:

- urban parks
- urban corridors
- disused railway alignments
- seaside promenades
- canal and riverside tracks
- river and coastal flood banks
- footpaths and bridleways
- amenity spaces such as golf course, racecourses, stately homes
- abandoned road alignments
- through open space provided by new developments

6.31.8 Each corridor will present its own, sometimes unique, set of challenges that will need to be overcome.

### **Track Widths**

6.31.9 Selection of an appropriate track width should accommodate forecast and target increases in users, including from planned land-use development. Providing a width greater than the minimum will increase the level of service for all users and accommodate future growth in active travel.

- 6.31.10 Walking and cycling are a social activities and this should be recognised in design if people are to be encouraged to travel actively. Routes should be wide enough to enable pedestrians to walk side by side and cyclists to ride two abreast wherever possible.
- 6.31.11 Available width will depend upon the nature of the route corridor. Re-using an old railway corridor is likely to permit a much wider track than a flood bank or canal towpath.
- 6.31.12 Cycle tracks should include additional width where they are bounded by vertical features. Only where there is open space on both sides is it practical to use the whole track width to cycle.

### **Junctions Between Traffic Free Routes**

- 6.31.13 Cycles cannot turn right angles, and pedestrians will often cut a corner and so providing right-angled junctions between tracks will result in adjacent areas becoming a rough desire line. However, blind pedestrians use right angle turns to aid navigation so additional guidance for them may be needed.
- 6.31.14 Junctions between tracks should therefore have a minimum 2m curve radius or 45° chamfer.

### **Speed Control Measures**

- 6.31.15 Generally the control of cycling speed is to be avoided, as it reduces the attractiveness of the mode as an alternative to short journeys by car. However excessive speeds by cyclists can be an issue where land or other constraints prevent minimum stopping distances or bends being provided; and on unsegregated shared use cycle tracks where approach speeds are high. Education of users may have some effect, but in many instances this will need to be complemented by physical measures.
- 6.31.16 Speed control options include:
- speed humps
  - bollards, including staggered layouts
  - deviations in the horizontal alignment
  - rumble strips
  - public art
  - signs/markings





6.31.17 Design issues to consider are as follows:

#### Accessibility

- accessibility to the track must be maintained for all legitimate users, including all types of cycle, pedestrians and wheelchair/mobility scooter users.
- any restriction in track width should slow down users as they negotiate it however a narrowing would also introduce a conflict point between users where different users have to give way to one another.
- width restrictions and barriers should generally be introduced as a last resort.

#### Siting of speed control measures

- careful consideration should be given to the location of any speed control measures and the distance between measures.

#### Visibility

- any feature that may present a hazard to users if encountered at speed should be clearly highlighted such that it is visible in daylight and darkness.

#### Maintenance vehicle access

- on many tracks it is necessary to facilitate access for maintenance, and other vehicles.
- this introduces additional complexity and any locking mechanisms could be subject to either the keys being lost or vandalism and would require additional maintenance.

#### Prevention of bypassing

- the design of any measure should ensure that any option for bypassing the measure provides at least the same level of speed reduction as the measure itself.

#### Speed humps

- if speed humps are specified in bituminous material consideration needs to be given to the ability of the contractor to construct the hump profile to acceptable tolerance. DE006 provides details of the preferred sinusoidal hump profile.
- precast concrete products are available which could be installed. However the cost of these units means that in most situations this option is likely to be prohibitively expensive. They also require a flat path profile otherwise they can rock and create a trip hazard.

- care should be taken not to locate speed humps on slopes such that the effect of the slope would be to increase the gradient of the hump beyond the maximum desirable slope of 1 in 20 (absolute maximum 1 in 12).

## 6.32. Cyclists on Links: Rural Roads

6.32.1 Whilst most cycling takes place in urban areas, some roads outside built-up areas provide key links for cyclists who live in rural areas when making active travel journeys to local facilities, including in nearby urban areas. Some designated areas consist of larger settlements surrounded by smaller settlements; the connecting routes between these settlements may be rural roads. Rural roads will also be used for leisure purposes by people enjoying the countryside.

6.32.2 Cycling on rural roads can often be difficult due to high traffic speeds. They often have poor visibility due to narrow carriageways with hedges and overgrown verges. It is therefore important that on active travel routes in rural locations, motor traffic speeds and volumes are reduced and suitable measures implemented to ensure cycling is safe and perceived to be safe.

6.32.3 Designated on-carriageway active travel cycle routes in rural areas should generally follow roads with low traffic flows, preferably below 1,000 vehicles AADT and with traffic speeds no greater than 30mph. In rural areas the design of cycle routes should be sympathetic to the local environment with careful use of signing and road markings.

6.32.4 Improving the rural cycle experience can be achieved by adopting and incorporating the various design features which aim to make rural roads safer and more pleasant places to travel by foot and cycle.

### **Gated Closures/Restrictions**

6.32.5 Closing or restricting access to minor roads is an effective way of improving rural conditions for walkers and cyclists. This can be achieved using a road closure with cycle gap, or restrictions such as signing traffic away from minor roads and designated cycle routes. These measures will require local engagement and consultation on TROs before implementation. It is important that any restrictions are signed in advance particularly at junctions to avoid unnecessary turning movements.



### Changed Priorities - Junction Redesign

- 6.32.6 Where two roads intersect, each with two-way traffic flows less than 1,000vpd, the road with the major cycle flow should be given priority. This can be achieved by relocating give-way markings and signs. Junctions can often be hidden in rural roads by bends and vegetation therefore it is important to consider improving and maintaining visibility splay at junctions.

### Reduced speed limits

- 6.32.7 The majority of the rural road network is subject to the national speed limit of 60mph. The geometry of many rural roads does not allow such speeds and where cycling is being encouraged, reduced speed limits along an active travel route should be considered.
- 6.32.8 However, speed limit changes on their own are unlikely to substantially reduce average speeds, therefore appropriate traffic calming measures should be considered especially at approaches to isolated hazards, junctions and bends.

### Quiet Lanes

- 6.32.9 Minor rural roads that are appropriate for shared use by walkers, cyclists, horse riders and motorised users may be designated as Quiet Lanes. They should have low traffic flows travelling at low speeds. This is achieved by community engagement and a combination of gateways, traffic signing strategies and restrictions. This concept identifies networks of rural roads rather than individual roads, which means it facilitates in widening transport choices and also helps to protect character and tranquillity in rural areas.
- 6.32.10 Quiet Lanes should be essentially self-enforcing however maintaining public awareness about Quiet Lanes is important and this can be done through local advertising. The Transport Act 2000 contains provisions which give local highway authorities the power to designate certain roads, for which they are responsible as Quiet Lanes, and has given the term 'Quiet Lane' legal status.
- 6.32.11 Section 268 of the Transport Act 2000 covers England and Wales. However, whilst regulations have been made in England, none have yet been made in Wales. Until Welsh regulations are made, local authorities in Wales will not be able to designate roads as quiet lanes.

### Centre line removal

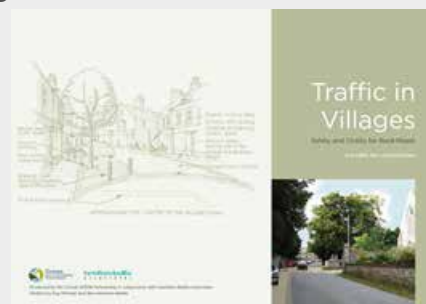
- 6.32.12 Centre lines can increase traffic speeds since they help guide motorists, and give them greater confidence to negotiate oncoming traffic. Consideration can be given to removing centrelines on lightly trafficked rural roads as part of an overall strategy to reduce traffic speeds.
- 6.32.13 Where traffic volumes are high or where HGVs frequently use a route, the introduction of motor traffic restrictions (e.g. signed HGV alternative routes, and/or weight & width restrictions) can reduce traffic volume, helping to create suitable conditions for centre line removal.

### Traffic in Villages

It is important that access in and around villages is suitable for active travel modes. Traffic in Villages is a publication produced by Dorset AONB Partnership which provides a toolkit that can be used for successful village design.

The mechanisms in the above publication for creating successful villages will also coincide in helping achieve better cycling conditions and facilities. These include reducing speed limits, creating gateways, improving crossing points, wayfinding measures, public spaces/meeting points, de-cluttering, etc. It is important that these principles do not inadvertently make worse cycle conditions by taking into consideration:

- Designing out existing and avoid creating pinch points (e.g. at gateways)
- Cycle access maintained at closures or restrictions
- Uncomfortable surface materials (e.g. cobbles)
- Retaining and improving upon cycle signing
- Car parking (ensuring echelon and other forms of parking do not create dangerous conditions for cyclists)
- Cycle parking



## Gateways

- 6.32.14 Gateways are used at village boundaries to raise driver awareness of an approaching settlement, where traffic speeds are intended to be reduced. These are points where it is necessary to reduce speed limits and physical traffic calming is often used to help enforce this measure. This can sometimes lead to pinch points for cyclists in areas where traffic speeds are still above 30mph.
- 6.32.15 Where pinch points are intended or have already been created, cycle bypasses should be provided see DE007.
- 6.32.16 Gateways do not have to take the form of a pinch point as they can be subtly created by using planting, different road colours/materials and other visual changes that mark the contrast between high speed roads and low speed villages. It should be a place where centre line markings end as this helps highlight a change in road character.

## 6.33. Transition between Cycle Tracks and On Carriageway Cycling DE034

- 6.33.1 The transition for cyclists between a cycle track (including a shared use path) and the carriageway needs to be safe and comfortable. Cyclists should be able to continue on their path, crossing a flush kerb at right angles, without having to turn sideways and give way to vehicles on the carriageway. The design of the transition point must ensure that cyclists are clearly visible so that motorists are aware that cyclists are likely to be re-joining the carriageway ahead of them.

### Photo 6.15 – Transition between Cycle Track and Cycle Lane, Liverpool





6.33.2 Transitions in the opposite direction – between a cycle lane and a cycle track – usually present fewer safety problems for cyclists, but should still allow cyclists to continue in a direct line, crossing a flush kerb at right angles.

### **Flush Kerbs**

6.33.3 The ability to move between cycle track and the carriageway, whether as part of a crossing manoeuvre or for cyclists joining or leaving the carriageway, is greatly helped by the type and quality of construction of the kerbs. This is particularly important if the kerb is to be crossed at a shallow angle, although designs should aim to modify kerb lines so that cyclists cross them at 90 degrees. Photo 6.17 shows an example of a flush kerb.

**Photo 6.17 – Flush Kerb**



## 6.34. Cyclists and public transport routes

6.34.1 Chapter 7 Integration with Public Transport focuses on the opportunities and benefits of integrating active travel modes with public transport operations. However, there are some design considerations to address where cycle routes interface with public transport routes, and these are discussed below.

### Combined traffic on bus routes

6.34.2 Where traffic speeds and volumes are sufficiently low to permit cyclists to share the carriageway with general traffic (see Table 6.2), sharing space with buses will not normally be a problem, subject to appropriate lane widths. However, where bus flows are high and form a large proportion of the traffic volume, consideration should be given to separating cyclists from buses, especially on primary cycle routes.

6.34.3 Frequent stopping and pulling out by buses will disrupt cycle flows and create a hazard, unless cyclists are able to bypass stationary buses (see DE028 DE029 DE030 DE031)

### Bus lanes and bus-only streets DE035

6.34.4 Generally cyclists are permitted to use with flow bus lanes. Whilst not specifically a cycle facility, bus lanes can provide a certain degree of segregation for cyclists in so far as they minimise the amount of motorised traffic in the affected lane. Some bus lanes also allow taxis and this can significantly increase traffic flows.

6.34.5 In order to be considered suitable to be an designated active travel route, the bus lane should still meet the criteria given in Table 6.2 – i.e. a separate cycle lane (and potentially a light segregated track) will be needed in some circumstances for the route to be considered suitable for inclusion on the existing route map.

6.34.6 Where bus lanes are provided, care should be taken to ensure that provision for cyclists in the opposite direction is not compromised.

6.34.7 There should be a presumption in favour of designing contraflow bus lanes to be of sufficient width to accommodate cyclists. Where this is the case the widths referred to in DE035 for with-flow bus lanes will apply. However, for short stretches, or where flows are low, narrow lanes may be acceptable, which will mean that buses will not be able to pass cyclists.





6.34.8 Where bus-only links are provided, for example between two residential neighbourhoods, the design should normally include provision for cyclists as well.

### **Cycling and trams**

6.34.9 Although only one mile of operational tramway currently operates in Wales, it is important to ensure that any potential future tramway schemes do not compromise the needs of cyclists.

6.34.10 In principle, cyclists and trams can share the same carriageway provided the tram travels very slowly. However, this requires extra care during the design phase as tram rails make it considerably harder to cycle and cyclists have to make sure they do not cross the rails at too shallow an angle; typically the approach angle should be at least 45 degrees, preferably 60 degrees. Tram rails also contribute indirectly to hazardous situations:

- cyclists may be concentrating on avoiding the rails that they fail to notice other hazards
- cyclists are not always able to choose a safe path
- rails restrict the scope for evasive manoeuvres

6.34.11 Generally a mixed profile of tram, car and cycle on main cycle routes should be avoided.

## **6.35. Crossing and Junction Design – General Principles**

### **Function, form and use**

6.35.1 The design of junctions and crossings must be comprehensible to all users, and it is essential that this is applied to pedestrians and cyclists as well as motorised road users.

### **User requirements for junctions and crossings**

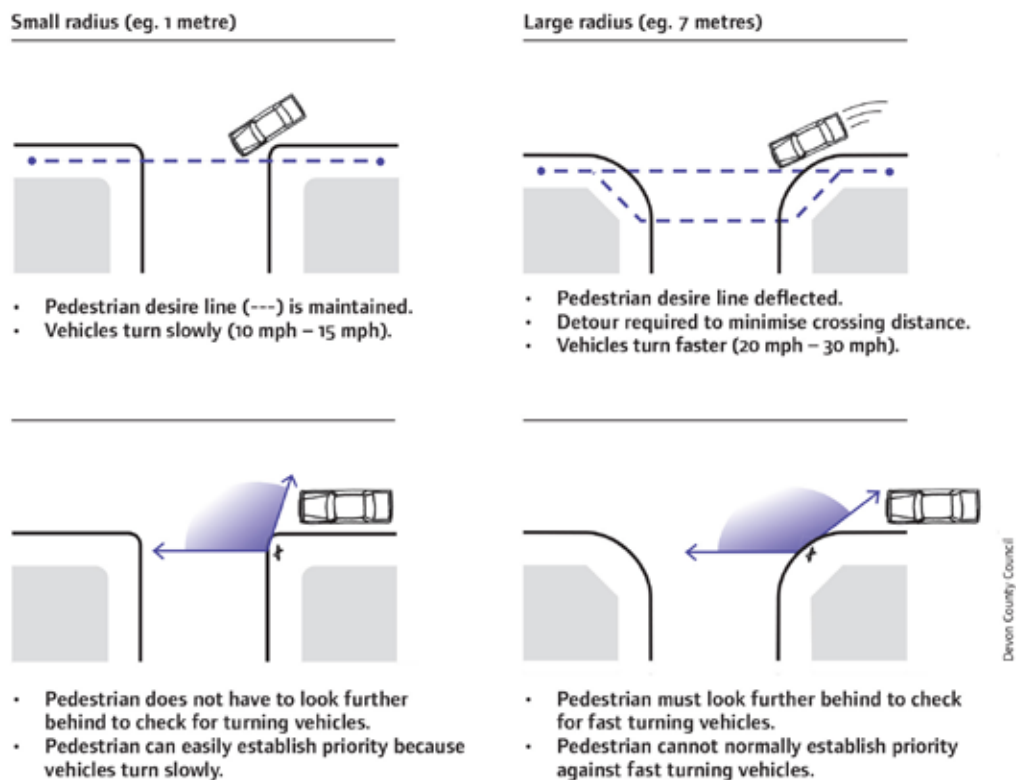
6.35.2 The user requirements of directness, safety and comfort are significant at junctions and crossings.

### **Directness**

6.35.3 Directness is important for both pedestrians and cyclists and the design of junctions and crossings should consider directness in both distance and time.

- 6.35.4 The delay experienced in negotiating a junction or crossing can considerably increase journey time for pedestrians and cyclists, both real and perceived. Reducing this delay may require amending the timings of traffic controlled junctions and crossings which may in turn affect junction capacities. If this is so a balance will need to be struck between overall junction capacity and pedestrian and cyclist delay. Where possible pedestrian and cycle routes should have priority over motorised traffic and designs should avoid arrangements that require frequent stopping and starting by cyclists.
- 6.35.5 Both pedestrians and cyclists require routes through junctions to follow natural desire lines. Where pedestrian routes are indirect many users will choose a shorter route if available, away from the formal crossing points.
- 6.35.6 At side road junctions deviations from the desire line can be minimised through the use of small corner radii. This has an additional benefit in reducing vehicle speeds.

**Figure 6.5 The effect of corner radii on pedestrians (from Manual for Streets)**



### **Safety**

6.35.7 Safety is a key consideration for pedestrians and cyclists at junctions and crossings, especially given that most collisions take place at them. Safe, well designed crossings can help overcome community severance created by busy roads.

6.35.8 Attention must be given to the need to minimise the risk of injury by

- avoiding conflicts as far as possible, and ensuring junction design minimise the number of conflict points
- minimising the number of traffic lanes through the junction
- reducing speeds at conflict points – to reduce both the number and severity of casualties
- ensuring good intervisibility between pedestrians, cyclists and other road users
- ensuring junction layouts are clear and unambiguous to all road users
- allowing sufficient time for pedestrians to cross the road and for cyclists to negotiate the junction.

### **Comfort**

6.35.9 Junction layouts need to ease the passage of pedestrians and cyclists by:

- ensuring a smooth surface with flush dropped kerbs with appropriate tactile paving
- careful location of street furniture so as not to obstruct desire lines
- allowing adequate space for pedestrians and cyclists waiting to cross.
- minimising hindrance due to stationary cars obstructing the crossing
- minimising the need for cyclists to stop and start
- geometry and visibility that enable cyclists to proceed through the junction or across the crossing unhindered.

## **6.36. Crossing Types**

6.36.1 There are two overall types of crossing – grade-separated, such as bridges and subways and at-grade crossings such as zebra crossings.

6.36.2 At-grade crossings are much more commonplace and relatively low cost. They are preferable to those grade separated crossings which would cause significant deviation away from desire lines and/or raise personal safety concerns. However, grade separated crossings can be a good



solution if they are well designed, and provide a high quality route over or under a road or other barrier. In some situations they may be the only possible solution, such as a crossing of a railway or motorway. Grade separated crossings are discussed later in this chapter.

6.36.3 There are two overall types of at-grade crossing:

- Uncontrolled crossings – pedestrian / cyclist usually has to give-way to road traffic, but in some cases these can be designed as a courtesy crossing where drivers are encouraged to give way to pedestrians / cyclists through the overall design; or can give priority to cycle traffic through the use of appropriate signs; and
- Controlled crossings – road traffic has to give-way to or stop for pedestrians and / or cyclists

6.36.4 The assessment of the need for and the type of pedestrian / cycle crossing to be provided in a particular location should be undertaken in accordance with Department for Transport and Welsh Government publication LTN 1/95 'The Assessment of Pedestrian Crossings'.

6.36.5 The design of pedestrian / cycle crossings should be undertaken in accordance with Department for Transport and Welsh Government publication LTN 2/95 'The Design of Pedestrian Crossings'.

6.36.6 Where there was no previous provision, suppressed demand may mean that crossing flows are higher than anticipated, especially in residential areas.

6.36.7 Various types of controlled crossings exist, either solely for pedestrians or shared with other non-motorised users. Signalised crossings may be standalone or incorporated into traffic signal controlled junctions.

6.36.8 Unsignalised Crossings:

- Zebra crossing
- Parallel crossing for pedestrians and cyclists (unsignalised)\*

6.36.9 Signalised Crossings:

- Puffin crossing
- Ped-X crossing
- Toucan crossing (shared with cyclists)
- Pegasus crossing (shared with equestrians)
- Crossings at traffic signal controlled junctions.

- 6.36.10 This guidance does not cover Pelican crossings, which are no longer authorised for new installations\* or Pegasus crossings.
- 6.36.11 In order to implement a new standalone (i.e. not part of a junction) controlled crossing it is necessary to consult with the police and give public notice of the proposal.
- 6.36.12 The layout of standalone controlled crossings is prescribed in The Zebra, Pelican and Puffin Pedestrian Crossings Regulations and General Directions 1997, which will be superseded by the revised Traffic Signs Regulations and General Directions (expected to be in force from March 2015). These regulations require particular markings, including the installation of a minimum of two zig-zag markings on the approach to and exit from the crossing, which prohibit vehicles waiting or overtaking on the immediate approach to the crossing.
- 6.36.13 The zig zag markings can be placed up to 2m from the kerblines, so that the zig zag markings can form a continuation of cycle lane, light segregation or hybrid track on the approach to the crossing.\*
- 6.36.14 Crossings of all types may be highlighted with the provision of kerb build-outs, which reduce the width of a crossing, and/or by placing the crossing on a raised table. Both of these measures are likely to be successful in reducing vehicle speeds in the vicinity of the crossing, though care should be taken to ensure build-outs do not result in a pinch point for cyclists using the road – see DE007
- 6.36.15 Consideration should be given to providing high friction surfacing on the approaches to a controlled crossing to ensure adequate skid resistance for braking vehicles. The length of high friction surfacing should be determined based on the vehicle approach speeds. The surfacing should continue past the stop or give-way line for at least one metre to cater for a vehicle overrunning the stop or give-way line.
- 6.36.16 Crossings need to be wide enough to cater for expected demand, and increased use. Once a new crossing is installed it will frequently be busier than originally expected. Catering for higher numbers at the design stage will avoid a route becoming compromised because dimensions were set at the minimum required. Once installed it can be difficult to justify further expense if a crossing needs widening.

## 6.37. Pedestrian crossings - General

- 6.37.1 An inability to cross the road safely can have a major impact on people's ability to safely and conveniently complete their active travel journeys on foot.
- 6.37.2 Pedestrian crossings should be provided at locations where a walking route crosses a major road or other barrier, and located as close to the pedestrian desire line as possible. Pedestrian crossings may be located at junctions, or they may be standalone. At signalised junctions pedestrian crossings should be incorporated into the traffic signals for the junction.
- 6.37.3 The principal types of crossings have been listed above and their main advantages and disadvantages are described in the following sections.
- 6.37.4 Where controlled crossings are provided some distance apart, consideration should be given to accommodating demand for informal crossings at more regular intervals. This might be desirable along a shopping street where pedestrians may want to cross at any point along a length of road, where there is no clear desire line.
- 6.37.5 At all signalised crossings, delays to pedestrians and cyclists should be minimised, by keeping cycle times as short as possible, providing maximum green times and setting standalone signals to respond immediately when the push button is pressed.

## 6.38. Uncontrolled crossings DE036 DE037, DE038, DE039 and DE040

- 6.38.1 The simplest form of uncontrolled or informal crossing involves the provision of dropped or flush kerbs so that mobility-impaired people can cross to and from the carriageway. They are less suitable for visually impaired people, who generally prefer signal-controlled crossings.
- 6.38.2 At uncontrolled crossings pedestrians do not have formal priority over road traffic. There are the following types of uncontrolled crossing:
- mid link crossing
  - crossing of side road junctions
  - informal crossing with a central median

- 6.38.3 Care should be taken over the siting of informal pedestrian crossing points in relation to vehicle crossovers so as not to cause confusion for visually impaired people. The effect of parked vehicles in the vicinity of an uncontrolled crossing should be considered and if necessary parking restrictions imposed.
- 6.38.4 Uncontrolled crossings can be highlighted in a number of ways if appropriate. These measures include demarking the crossing with a different coloured surface.
- 6.38.5 Uncontrolled crossings can also indicate clearly to drivers where pedestrians are encouraged - and are therefore likely - to be crossing. Designs can make use of contrasting paving materials, street furniture and changes in carriageway width and level to emphasise pedestrian movement. When done well, in a slow traffic speed environments, they will often encourage drivers to give informal priority to pedestrians.
- 6.38.6 A refuge in the centre of the carriageway enables pedestrians to negotiate one stream of traffic at a time, which can be of considerable help when flows are high. Refuges tend to be kerbed in order to provide a degree of protection to pedestrians. Flush kerbs and tactile paving should be provided in line with the dropped kerbs at the edge of the road. The refuge is usually marked with bollards facing approaching traffic, although their over provision can have an impact on the streetscape – guidance on the provision of traffic bollards is given in Traffic Advisory Leaflet 3/13.
- 6.38.7 Uncontrolled pedestrian crossings will usually be provided across the minor arm at side road junctions. Flush kerbs on the junction radii can create difficulties for visually impaired people. Therefore, where possible, crossings at side roads should be inset into the side road approximately one metre beyond the end of the radii. Tighter radii will enable this set-back to be reduced so that pedestrians are not diverted from their desire line. Alternatively a ‘side road entry treatment’ may be appropriate to enable the crossing to be located closer to the pedestrian desire line – see below.



## 6.39. Side Road Entry Treatments and Blended Junctions DE039 and DE040

- 6.39.1 Side road entry treatments involve raising the mouth of the side road junction to footway level. They make it considerably easier and safer for pedestrians to cross – particularly mobility impaired people– by enabling pedestrians to cross along a level profile. They also assist pedestrians by reduce the speeds of turning vehicles and shortening the length of the crossing.
- 6.39.2 Side road entry treatments are also beneficial to cyclists, whether they are on the main carriageway or on cycle tracks/routes crossing the side road.
- 6.39.3 A variant on this is the ‘blended’ junction, where there is no change in the footway material, no flush kerbs and no tactile paving, where vehicles are effectively crossing a widened footway. Choice of locations for this design should take account of the needs of older pedestrians and disabled people.

**Photo 6.18 – Typical Side Road Entry Treatment, Hammersmith and Fulham**



## 6.40. Central median strips to facilitate informal crossing points DE041

- 6.40.1 Central median strips are an area of different coloured or textured surfacing in the centre of a road which provide space for pedestrians to wait in while crossing a road in two stages. Central medians also encourage drivers to give priority to pedestrians at informal crossings. This type of facility should be in addition to crossings suitable for less mobile or visually impaired pedestrians. Central medians can be kerbed, raised or flush with the carriageway surface – see Photo 6.19.

**Photo 6.19 – Informal Median Strip, Poynton, Cheshire**



## 6.41. Zebra crossings DE042

- 6.41.1 Zebra crossings give pedestrians priority over all other traffic. In some authorities there has been a move away from providing zebra crossings towards signalised crossings, on the basis that they represent an 'upgrade' but this is not necessarily the case.
- 6.41.2 Zebra crossings are un-signalised crossings with transverse white bars painted onto the road surface and yellow flashing globes (belisha beacons) on black and white striped poles at each side of the crossing. A driver is required to stop at a zebra crossing when a pedestrian starts

to cross. A blind person however may not be able to detect that a vehicle has stopped and therefore may be hesitant about commencing using the crossing. Other vulnerable groups such as people with learning impairments and older people are also likely to prefer signalised crossings where they may feel safer and more comfortable.

- 6.41.3 Zebra crossings may be divided into two parts by a central refuge or median, which will improve the quality of provision for pedestrians.

## 6.42. Signalised crossings DE044 and DE045

### Standalone signalised crossings

- 6.42.1 There are a number of variant types of standalone signalised crossings:

#### Puffin Crossings

- 6.42.2 Puffin crossings are standalone crossings with nearside pedestrian red and green symbols located as part of or above the push button unit located so that they can be seen at the same time as approaching traffic. Puffin crossings are gradually replacing Pelican crossings in many authorities, which are no longer authorised for new installations\* Puffin crossings incorporate detection technology (usually microwave detection) which allows cancellation of the pedestrian demand if a pedestrian crosses after pressing the button, but before the green man has activated. Additionally, the detectors are used to measure the speed at which pedestrians are crossing and automatically adjust the time allowed to cross the road. A Puffin crossing has the same light sequence as traffic signal junctions (i.e. no flashing amber road traffic signal/flashing green man, as used at Pelicans).

#### Ped-X Crossings

- 6.42.3 A Ped-X crossing is a newer type of crossing, similar to a Puffin crossing in terms of signal sequence and detection, but with farside pedestrian signal aspects. 'Countdown' displays which show the time in seconds to the end of the crossing period, can be used with Ped-X crossings. Ped-X crossings are more suited to busy locations where pedestrians may have difficulty seeing the nearside indicators due to crowding.

#### Toucan Crossings

- 6.42.4 Toucan crossings are shared pedestrian and cycle crossings, and are similar to Puffin crossings, but with additional red and green cycle symbols. They can have nearside or farside aspects, and can also include countdown displays.

## 6.43. Crossings at signal controlled junctions

- 6.43.1 Crossing facilities for pedestrians can be incorporated into signal controlled junctions by providing pedestrian signals. Crossings within traffic signals may have nearside or far side pedestrian aspects, as well as combined pedestrian and cycle crossings.
- 6.43.2 Pedestrian (and if appropriate cycle) crossing facilities should normally be provided on all arms of a junction, and the number of separate crossing stages that a pedestrian/cyclist has to use to cross at a junction should be minimised.
- 6.43.3 Signal controlled crossings should include crossing times of suitably long duration to allow all pedestrians (particularly older people) to cross the road in an efficient unhurried manner. Research by University College London has revealed that a walking speed 1.2m/s, which is often used to set the length of pedestrian stages, is too fast for 85% of women and 76% of men aged 65 and over. Crossing timings can accommodate slower pedestrians through the use of detectors and extensions. Where stage timings are fixed, slower walking speeds should be considered wherever there are significant numbers of elderly or less able people present.
- 6.43.4 Signalised crossings may be divided into discrete sections using refuges, with each part of the crossing operating on different stages of the signals for traffic capacity reasons. Such crossings are normally staggered so that pedestrians recognise each part of the crossing as separate, although there are examples of straight ahead signalised crossings with wide central refuges that operate under separate stages. Staggered crossings involve additional delay and deviation from the desire line, particularly where the stagger is large. Straight ahead crossings are much more convenient for pedestrians and should be used wherever possible.
- 6.43.5 Audible and tactile signals should be provided for sensory impaired pedestrians at signal controlled crossings.
- 6.43.6 The volume of an audible signal can be manually adjusted to suit the environment. Where there are a number of crossings in close proximity, or two stage crossings are used without a long stagger, standard audible signals may cause confusion. In this case bleep and sweep audible signals can be provided. These use a directional speaker and an adjustable volume to assist pedestrians in the vicinity of the crossing.

- 6.43.7 Tactile signals are rotating cones located on the underside of the push button unit. Care should be taken to ensure that pedestrians can reach the rotating cone and access the crossing without being obstructed by any guard railing. Rotating cones should be located on the right hand side of a crossing.
- 6.43.8 Pedestrian countdown timers can be installed at Ped-X crossings and pedestrian facilities at traffic signals. These give crossing pedestrians a display which informs them how many seconds are left for them to cross after the green man light has gone out, during the 'black-out' period and before the red man light comes on.
- 6.43.9 The countdown timers remove uncertainty for pedestrians as to how long they have to safely cross and can therefore improve pedestrian comfort and the efficiency of traffic signal timings. Pedestrian countdown timers can only be used at crossings with far side pedestrian signals with fixed 'black-out' times. This means that they cannot be installed at Puffin Crossings.

## 6.44. Cyclists at Crossings - General Principles

- 6.44.1 As with pedestrians, cyclists will need crossings to enable them to continue their journey across a busy road or other barrier which crosses a designated cycle route. Although reference in this section is made to cycle crossings, they can in fact be thought of as junctions, but where one or more arms of the junction are only used by cycle traffic.
- 6.44.2 Table 6.3 is indicative of the appropriate treatments for a standalone cycle crossing of a two-way carriageway. It is a guide only, and individual locations should be assessed on a case by case basis. In many situations reducing the speed of traffic using the carriageway will open up additional options for the crossing design.

**Table 6.3: Choice of cycle crossing type**

85th percentile speed of road traffic	Road traffic 2 way flow AADT	Type of cycle crossing
Side Road Crossing		
30 mph and below (main road)	≤2,000 on side road	Cycle priority crossing on raised table
30 mph and below (main road)	>2,000 on side road	Cycle crossing on raised table, cyclists give way
Above 30 mph (main road)	Any	Cyclists give way, crossing not raised
Main Road Crossing (Standalone)		
30 mph and below	≤ 4,000	Cycle priority crossing on raised table
Above 30mph, up to 50 mph	≤ 6,000	Cyclists give way to road traffic
35 mph and below	≤ 8,000	Parallel crossing for pedestrians and cyclists*
Above 30mph, up to 50 mph	≤ 8,000	Cyclists give way to road traffic plus central refuge – urban
Above 30mph, up to 60 mph	≤ 10,000	Cyclists give way to road traffic plus central stage refuge – rural
Up to 50 mph	> 8,000	Toucan Crossing
> 50 mph	> 8,000	Grade separated crossing – urban
> 60 mph	> 10,000	Grade separated crossing - rural

**Source: Based on LTN2/08 & Cycling England**

- 6.44.3 Uncontrolled crossings should be at least the width of the approach paths, and never less than 2.7m wide (3m dropped kerb width). Therefore if the approach path is a cycle track, or shared use path 3.5m wide then the crossing should not narrow down and create pinch points but provide a facility 3.5m wide.



## 6.45. Cycle priority crossings DE037

6.45.1 Where an active travel cycle route crosses a relatively lightly trafficked street, it should preferably be given priority over the road. Care needs to be taken to ensure it is clear to motorists that they must give way, and that there is sufficient visibility along the cycle track. At present the crossing needs to be located on a speed hump in order to comply with TSRGD.

**Photo 6.20a and b – Cycle Priority Crossing, Bristol**





## **6.46. Simple uncontrolled crossings DE036**

6.46.1 On busier roads cyclists crossing will need to give way to motor traffic unless a controlled crossing is provided. However, cyclists will generally be able to cross conveniently in a single movement with traffic volumes up to around 6000vpd.

## **6.47. Uncontrolled crossing with refuge DE038**

6.47.1 Where cycle routes cross roads with speed limits above 30mph or where vehicle flows are high, it can be difficult to find an adequate gap in the traffic to cross the carriageway in one movement. A central refuge allows crossing to be undertaken in two easier movements, but the arrangement needs to be carefully designed to avoid the refuge creating pinch points that can disadvantage cyclists using the carriageway.

## **6.48. Parallel Crossing for Pedestrians and Cyclists DE043\***

6.48.1 This type of crossing provides a more demand responsive and lower cost solution to accommodate cycle and pedestrian crossing movements next to each other, compared to signalised facilities.

6.48.2 The crossing is similar to a zebra crossing, but with a separate cycle crossing indicated by 'Elephants Footprint' markings and diagram 1057 cycle symbols located between the zebra stripes and the give way line. The regulations require zig zag markings and yellow flashing globes (belisha beacons) on black and white striped poles at each side of the crossing.

6.48.3 The parallel crossing is visually stronger than the cycle priority crossing (DE037) and drivers are more likely to respect the legal requirement to give way. It is therefore suitable for sites with higher traffic flows and speeds. It can also be used close to junctions, for example on the entries/exits to roundabouts.

6.48.4 As with zebra crossings, parallel pedestrian/cycle crossings may be divided into two parts by a central refuge or median, which will improve the quality of the crossing for both pedestrians and cyclists.

**Photo 6.21 – Parallel Crossing for Pedestrians and Cyclists  
(installation in advance of revised TSRGD)**



**(Note – give way markings for cyclists will not be required when revised TSRGD is published, and diagram 1057 markings may be used on cycle crossing)**

#### **6.49. Signalised Cycle and Pedestrian Crossings (Toucan) DE045**

- 6.49.1 Signalised crossings in urban areas enable pedestrian and cycle movements across busier roads and take the form of a toucan crossing, where cyclists and pedestrians share the same crossing space.
- 6.49.2 Toucan crossings can use nearside or farside aspects, depending on local requirements. Crossings with farside aspects can be equipped with countdown displays, similar to a Ped-X crossing.

#### **6.50. Pedestrian / Cycle Bridges DE046**

- 6.50.1 Well-designed bridges can provide very useful connections for footpaths and/or cycle tracks, enabling crossing of major roads or other barriers to take place without conflict or delay. Where the topography is favourable the need for approach ramps can be minimised and good natural surveillance improves personal security. New bridges can be designed

as features along a route and may become attractors in their own right, and are generally considerably cheaper than new subways. Segregation of the crossing between pedestrians and cyclists is preferred, as shown on the example from Cambridge in Photo 6.22. Where this is not practicable, consideration will need to be given to whether unsegregated use is appropriate.

**Photo 6.22 – Covered segregated pedestrian/cycle bridge, Cambridge**



## 6.51. Existing road bridges

6.51.1 Existing road bridges often have very high cycle flows and can be adapted to accommodate cycle tracks. Existing structures with narrow footways, restraining barriers or lower parapets should not be discounted, as it may be feasible to reduce the carriageway width.

## 6.52. Subways / underpasses DE047

6.52.1 Well-designed subways / underpasses can provide useful connections along footpaths or cycle tracks away from the road, avoiding conflicts at barriers such as major roads, railways and watercourses. Where the topography is favourable the need for approach ramps can be minimised and good natural surveillance is essential for personal security. Sometimes this option will involve the conversion of an existing pedestrian subway or an underpass provided for private access where safe and appropriate taking account of the needs of all users. Where this is not practicable, consideration will need to be given to whether unsegregated use is appropriate.



**Photo 6.23 – segregated cycle track on Cardiff Bridge, Cardiff**



**Photo 6.24 – Segregated pedestrian/cycle route beneath busy intersection with good natural light – Lund, Sweden**



B



### 6.53. Wheeling Ramps DE048

6.53.1 In some situations, flights of steps are sometimes unavoidable on a cycle route. To assist cyclists, wheeling ramps should be added to one or both sides of the flights using steel sections or by forming them in concrete.

### 6.54. Cyclists at Priority Junctions

6.54.1 At major/minor arm priority junctions, opposing turning flows give way according to defined priority rules, which are indicated through traffic signs and markings. Priority is normally given to the dominant traffic flow.

6.54.2 Four overriding principles underpin the design of priority junctions that are safe and suitable for cyclists:

- low speeds – on approaches and through the junction;
- good intervisibility;
- single lane approaches;
- designs that facilitate correct positioning and offer protection for right turns from the major arm.

6.54.3 The following design details are recommended:

- change of priority to assist the major cycle flow and reduce traffic speeds. This is typically used on low-traffic streets (up to 3000vpd) where there is not a dominant traffic flow, and may need kerb deflection to support compliance. Changes in priority can signal a change in movement and place function and can support environmental enhancements;
- minimise kerb radii particularly in urban areas with low flows of medium sized delivery vehicles (e.g. business / industrial parks). Vehicle tracking will be necessary to design appropriate radii where regular use by HGVs is intended. It will be acceptable in many 30mph situations for large vehicles to cross centre lines – for further guidance on corner radii refer to Manual for Streets 2 Section 9.4. There may need to be some local strengthening of the footway to allow for larger vehicles occasionally overrunning the corner, or the placing of a bollard or other obstruction to ensure that this does not occur.
- narrow traffic lanes on junction approaches to reduce traffic speeds and reduce crossing distance for pedestrians. This can release space to accommodate cycle lanes or tracks, where needed;

- provision of Side Road Entry Treatments or Blended Junction (See Section 6.38) to reduce the approach speed of vehicles on the minor arm.
- the provision of long tapers and left-turn lanes, and in particular free-flowing entry and exit slip lanes, can cause safety and comfort problems for cyclists who are not turning. They should be removed wherever possible from existing junctions and avoided on new layouts.
- provision of right turn lanes / ghost islands where cyclists are likely to have to wait for a gap in oncoming traffic to turn right;
- provision of nearside cycle lanes of appropriate width across the minor arms at junctions (see Section 6.22). This can help to emphasise route continuity for cycle users and can increase awareness of cyclists to motorists turning across the cycle lane
- where a cycle track alongside the carriageway crosses side roads, the aim should be for the cycle track to retain priority and follow the desire line wherever possible

## 6.55. Unmarked Informal Junctions DE048

- 6.55.1 Junctions in urban areas, even on relatively busy routes, can be designed without defined priority, requiring road users to slow down and engage / negotiate with other road users. The application of these 'shared space' principles (see Section 6.9 for further guidance) is becoming increasingly common and has been demonstrated to be effective in terms of traffic capacity and safety on four-arm junctions with peak period flows in excess of 2500 vehicles/hour. Examples include junctions in the centre of Coventry, in Poynton in Cheshire and in Bexleyheath in outer London.
- 6.55.2 Informal junctions can also use circular paving patterns to indicated roundabout-type priority without the use of road markings and signs. These informal roundabouts are discussed in Section 6.70 below.
- 6.55.3 In terms of cycling, this type of junction can work well as long as care is taken to ensure that the paths of motor vehicles through the junction are limited to one lane, and speeds do not exceed 20mph, so that cyclists can adopt a primary position throughout.

**Photo 6.25 – Informal Junction with no marked priority, Poynton, Cheshire**



## 6.56. Cyclists at Signalised junctions - General considerations

### **Safety**

- 6.56.1 Signal-controlled junctions can provide safety benefits for pedestrians and cyclists by separating opposing traffic movements in time and reducing the need for weaving manoeuvres.
- 6.56.2 Accidents which occur at signalised junctions are often related to conflict between left turning vehicles and straight ahead cycle movements and designers need to consider how to minimise this.

### **Delays**

- 6.56.3 Signalised junctions can reduce delays for cyclists and pedestrians during peak traffic periods and can manage and facilitate specific turning /crossing movements which may be difficult under priority control. This can give cyclists a time advantage over other traffic.
- 6.56.4 However, signal controlled junctions commonly result in increased delays during off-peak conditions, compared to a priority junction.
- 6.56.5 Cyclists do not like stopping because they lose momentum. Uninterrupted left turns or ahead movements at T junctions can be created by including cycle bypasses where space exists. In other situations, priority control may be preferable on cycle routes to minimise the need to stop and start.



- 6.56.6 As a minimum, consideration should be given to the provision of advanced stop lines (ASLs) and lead in lanes at all signalised junctions to enable cyclists to bypass queues and to help cyclists position themselves correctly for their turning movement. ASLs are not the only way of providing for cycling, however, and can have some disadvantages which are discussed below.

### **Designing for cyclists' needs**

- 6.56.7 The design of signalised junctions should consider all movements by all types of user; and how different user groups interact with each other. Many issues can be designed out, if cycle movements are considered early in the design process.
- 6.56.8 Minor timing changes to existing signal junction operation can provide significant advantages to cyclists at some junctions, without the need for complex re-signalling works. Some signalised junctions do not require significant changes to the existing timings in order to provide good quality solutions for cyclists. Traffic modelling can help determine whether minor timing changes will have a negative impact on network capacity.
- 6.56.9 For example, the Connect2 scheme at Finsbury Park adjusted the timings at a signalised junction on Seven Sisters Road such that the minor road approach could be reduced from three to two lanes, thus enabling provision of a cycle track and toucan crossing at that junction without adversely affecting other traffic movements.
- 6.56.10 Where cyclists share space with pedestrians, rationalisation of street furniture and single phase crossings will help reduce conflict. Parallel provision for cycles and pedestrians to cross junctions can further reduce conflict between these user groups. Puffin & toucan crossing technology can be used to detect slow moving cyclists and pedestrians through a junction to delay the next signal phase until they are clear.

### **6.57. Advanced stop lines (ASLs) DE050**

- 6.57.1 An Advanced Stop Line (ASL) enables cyclists to take up the appropriate position in the 'reservoir', or waiting area between the two stop lines, for their intended manoeuvre ahead of general traffic, before the signals change to green. A cycle feeder lane should normally be provided which will enable cyclists to easily pass queuing motor traffic on the approach to the stop line. They are established practice in most highway authorities and some local highways authorities now have a presumption to install ASLs at all signalised junctions.

- 6.57.2 ASLs may not resolve all problems for cyclists at traffic signals however. ASLs provide benefit to cyclists on an approach when the traffic signals are on red. They have little value on approaches that are free-flowing for most of the cycle, and/or approaches with multiple lanes, as cyclists will find it difficult to manoeuvre themselves into an offside lane to make a right turn. In these situations alternative solutions should be considered.
- 6.57.3 ASLs have little or no effect on capacity if the number of general traffic lanes remains unaltered.
- 6.57.4 Feeder lanes are usually provided on the nearside, but where there are high numbers of left turning vehicles crossing cyclists going ahead or right, central or offside feeder lanes between general traffic lanes should be considered.
- 6.57.5 'Gate' entries to ASLs are an option which allows legal entry to the reservoir where a lead-in lane cannot be achieved and no longer require authorisation. However, in all cases, a lead-in lane is preferable; gates represent a lower level of service for cyclists and should not normally be used on active travel routes.
- 6.57.6 It is possible to have an ASL with neither a lead-in lane nor a gate, but this is not a preferred arrangement.\*
- 6.57.7 ASLs are not permitted at non-signalised junctions, or toucan / puffin crossings, but several authorities have installed them immediately adjacent to a standalone signalised crossing point.
- 6.57.8 An 'early start' signal phase for cyclists (also known as a 'cycle filter') in conjunction with an ASL enables cyclists to start ahead of other traffic and to clear locations of potential conflict with traffic on the same arm (e.g. overtaking and turning left) or opposing traffic streams. Under this arrangement a green cycle light is illuminated at the start of the stage, and is followed by a full green signal.
- 6.57.9 The use of early start cycle signals has recently been authorised in Cambridge (see Photo 6.25), York and Manchester and authorities in Wales may wish to use similar designs. These do not require authorisation\*. Again this type of arrangement does not confer any advantage while the approach signals are on green, however.

6.57.10 Low level cycle signals, currently on trial in London, are now permitted to replace the high level cycle advance signals shown in Photo 6.28.\*

**Photo 6.26 - Early Start Cycle Filter at ASL, Cambridge**



## 6.58. Cycle signal phases

6.58.1 A dedicated phase for cyclists, controlled by cycle signals, can be an appropriate solution where a cycle track, or cycle-only on-road provision (including contraflow facilities or cycle routes through road closures) enters a signalised junction. Cycle signal phases enable cycle and motor traffic movements to be separated in time. They can be on demand, using detector loops or push buttons, or can be included within fixed staging.

6.58.2 Cycle-only phases can be useful, for example:

- where cyclists need to be separated from other traffic for safety reasons for example a nearside cycle track could be given a dedicated green signal while the left turn across the track for general traffic is held on red.
- where cyclists can undertake a manoeuvre not permitted for general traffic, and which is not shared with pedestrians, such as travelling between the carriageway and a cycle track

- 6.58.3 Cycle signals can be at the same height as normal signals, but these are difficult for cyclists to see when they are close to them.
- 6.58.4 Smaller sized low level signals which have a red cycle aspect are currently under trial in London and are now permitted under TSRGD\* . A red cycle aspect may be used on both high level and low level signals.\*

**Photo 6.27 – Separate Cycle Phase with High Level Cycle Signals, Camden**



**Photo 6.28 – Low Level Cycle Signals and Red Cycle Aspect on trial at Bow Roundabout, London.\***



## 6.59. Exemption for cyclists from banned turns

- 6.59.1 There are many examples of cyclists being successfully exempted from banned turns at signals, and this should always be included in the layout and staging arrangements in order to give cyclists an advantage over motor traffic, unless there are overriding safety problems.
- 6.59.2 For example, where there is a bus-only movement it should normally be feasible and desirable also to include cyclists. There will also be situations where a cycle-only exemption is appropriate.

## 6.60. Intergreens for cyclists

- 6.60.1 Cyclists coming through a signal junction at the end of the green phase may be travelling significantly slower than motor traffic, due to an uphill gradient or the route through the junction being longer for cyclists. This has the potential to place cyclists in conflict with traffic moving off at the start of the next stage.
- 6.60.2 This safety problem should be addressed by increasing the intergreens, normally by increasing the intergreen to a suitable value, or by including an all red extension when a cyclist is detected who has not cleared the junction. The latter solution will require a reliable system of detection.

## 6.61. Permanent green cycle signal on bus gate

- 6.61.1 Increasingly traffic signals are being used at bus gates to provide queue relocation on the approach to a signalled junction. Several cities, including Cambridge, have incorporated a permanent green cycle aspect on the bus gate signal as there is no need to stop cyclists when other traffic has a green signal.

**Photo 6.29 – Permanent Green Signal at Bus Gate - Cambridge**





## 6.62. Diagonal cycle crossing stage during all red

- 6.62.1 Where there is a demand for cyclists to cross a four-arm signalised junction diagonally, providing a direct diagonal crossing may be preferable to directing them across one arm at a time. Diagonal crossings will increase the overall crossing distance that a pedestrian or cyclist is required to make in one movement – therefore increasing the length of the red stage for other traffic – but it allows users to replace a “two stage” crossing movement with a “single stage”, reducing their journey times.
- 6.62.2 At junctions where pedestrians cross on an all red stage, it may be feasible for a diagonal cycle crossing to be installed without increasing the duration of the vehicle all-red stage. Cardiff and Birmingham both have signalised junctions which incorporate diagonal crossings for cyclists.

**Photo 6.30 – Signalised Diagonal Cycle Crossing, Cardiff**



## 6.63. Cycle bypasses at traffic signals DE051

- 6.63.1 Where space and the level of pedestrian use allow, it is often possible to provide a slip off in advance of a signalised junction, leading to a short section of cycle track that enables the cyclist to bypass the red signal.



6.63.2 This is commonly used in two situations:

- to turn left;
- to continue straight ahead at the head of a T junction

**Photo 6.31 – Cycle Bypass at Signals, Brighton**



**Photo 6.32 - Cycle Bypass at Signals, City of London**





## 6.64. Uncontrolled cycle crossing at signalled junction

6.64.1 At some signalled junctions operational considerations may make it very difficult to justify a separately controlled crossing for cyclists. In such cases it may be appropriate to consider an uncontrolled cycle crossing of an arm of the junction, with the cycle track approaches marked as give way. This also has the advantage that cyclists are not faced with a full red signal at a time when it is quite safe for them to cross.

## 6.65. Guiding cyclists through signalised junctions DE052

6.65.1 A cycle lane marked through a signalised junction provides a visible indication of route continuity and can increase the drivers' awareness of key cycle movements. They are commonly used in two situations:

- to indicate route continuity and protect space for cyclist desire lines on important cycle routes
- to mark out cyclist turning manoeuvres which are different to or not permitted for general traffic movements.

6.65.2 A road marking to diagram 1010 should be used for this purpose (1m line, 1m gap)\*. This is a more prominent marking than an advisory lane to diagram 1004 and is preferred.

6.65.3 Route markings through junctions will be subject to high levels of wear and will require maintenance.

### Photo 6.33 – Cycle lane through signalised junction, Oxford Road, Manchester



Note – Diagram 1010 markings are preferred\*

- 6.65.4 Where it is necessary to indicate a less obvious route for cyclists through a signalised junction it may be marked using “Elephants Footprints” markings (formerly referred to as Diagram WBM 294), which no longer require authorisation.\*

**Photo 6.34 – Elephants Footprint Markings at Traffic Signal Junction, London**



### 6.66. Two stage right turn at traffic signals DE055

- 6.66.1 Based on a standard feature at junctions in the Netherlands and Denmark, this arrangement provides a right turn facility for cyclists at a signalised crossroads as an alternative to an ASL.
- 6.66.2 It can be of particular benefit on a multi-lane approach where speed and volume of motor traffic makes the execution of a conventional right turn manoeuvre hazardous and unpleasant for cyclists, even with an ASL.
- 6.66.3 Provision is made for cyclists to pull in to the road on their left in advance of the stop line and any pedestrian crossing and wait there until that road has a green signal, at which point cyclists can make a straight across movement to complete their right turn. It is relatively untried in the UK, with a scheme having recently been installed in Southampton.

**Photo 6.35 - Two stage right turn signalised junction, Southampton**



- 6.66.4 Cyclists waiting to complete the right turn in advance of the stop line must be able to see a secondary signal on the far side of the junction in order to know when it is safe to proceed.
- 6.66.5 An 'early start' signal phase for cyclists using low level signals 4th aspect cycle filter can be used to reduce conflict with left turning traffic – see 6.55 and DE050 for further guidance.

### **6.67. Trixi Mirrors (Blind spot mirrors)**

- 6.67.1 Blind spot road side mirrors are large convex mirrors installed at left turns on signalised junctions to enable drivers of large vehicles (buses and HGVs) to see down the nearside of their vehicles. These are intended to address the significant number of serious casualties caused by large vehicles turning left across cyclists on their nearside. Manchester is the latest UK city to start to install these at key junctions across the city.
- 6.67.2 The Department for Transport has authorised their use throughout England and they will be now prescribed in TSRGD.\*

- 6.67.3 There is some debate as to whether Trixi mirrors are effective once a vehicle is moving, and whether improvements to junctions needs to include removal or reduction of guard railing as well as Trixi mirrors to deliver maximum benefit. Each local authority in Wales will have their own policy on the introduction of Trixi mirrors.

**Photo 6.36 – Trixi mirror on Cycle Superhighway 7, London**



## 6.68. Cycle provision at signalised roundabouts

- 6.68.1 Large roundabouts are a serious problem for most cyclists. However, signalising them can assist cyclists by introducing control of the main traffic movements. Many of the measures described above can be applied at the individual nodes around signalised roundabout, but each situation will require a bespoke design.
- 6.68.2 To accommodate cyclists using them, ASLs should normally be considered for each entry arm and if stacking space permits ASLs may also benefit cyclists on the circulatory carriageway. In addition providing an early start for cyclists may be beneficial.



- 6.68.3 Less experienced cyclists are likely to prefer an off carriageway route around the roundabout or across the central island, with signal control across the busier entries and exits. Temple Quay in Bristol provides both options – see Photo 6.37.

**Photo 6.37 – Signalised Roundabout at Temple Quay, Bristol, with cycle facilities on carriageway and separate cycle track around the junction.**



### 6.69. Cyclists at Roundabouts – General Principles

- 6.69.1 Roundabouts can offer capacity advantages over other forms of junction, but they can be hazardous for cyclists when designed in accordance with typical UK practice. Conventional roundabouts often have entries and exits that are flared, with two or more lanes to increase vehicle capacity, and wide circulatory carriageways which are often unmarked. Deflection may be less than desirable because of the constraints on the space available. The relatively smooth path for motor vehicles can result in high traffic speeds through the junction and on the exit, particularly on large diameter roundabouts
- 6.69.2 Finding a safe position to occupy in a wide circulatory carriageway may be difficult, and cyclists are at risk of not being noticed by drivers entering or leaving the junction at relatively high speeds.
- 6.69.3 Roundabouts with a dedicated left turn slip lane to increase capacity pose an additional hazard for cyclists, both where the lane diverges and on its exit, where a cyclist travelling straight ahead will leave the roundabout between two fast moving traffic lanes. They are not recommended for active travel routes wherever on-carriageway cycling can be expected.

- 6.69.4 In general there are two ways of dealing satisfactorily with cyclists at roundabouts, either:
- use mini or compact roundabouts where traffic where traffic volumes are relatively low and speeds are slow, and the lane widths are relatively narrow so that cyclists can safely share single lane entries, exits and the circulatory carriageway in the primary position; or
  - where traffic volumes are higher, and at larger roundabouts, provide a separate cycle track around the outside of the junction, preferably with cycle priority or signal-controlled crossings of the entries and exits.
- 6.69.5 In addition, cycle routes can cross roundabouts via grade separated facilities, as discussed in Sections 6.48 and 6.50.
- 6.69.6 New roundabouts, or those that can be adapted, offer opportunities to address the issues listed above through a change in design thinking. The design approaches listed below will make roundabouts safer for cycling and less dominated by motor traffic:
- control vehicle speeds to around 20 mph through the junction
  - reduce the amount of space for motor traffic
  - raise driver awareness of cyclists
  - provide unobstructed passage for cyclists through or around the junction
- 6.69.7 These are design features of ‘compact’ roundabouts, which are discussed further below.
- 6.69.8 Cycle lanes on the outside of the circulatory carriageway are not normally recommended, even on compact roundabouts, since cyclists using them are vulnerable to ‘left hook’ collisions with motor vehicles exiting the junction.
- 6.70. Mini Roundabout DE054**
- 6.70.1 Mini roundabouts, where the external diameter is not greater than 15m, can be good alternatives to retaining priority junctions. The design of mini roundabouts is included in TD54 of the DMRB. By providing tighter radii they contribute to slower vehicle speeds, and can be included in traffic calming schemes. Single lane approaches mean that cyclists and motor traffic pass through the roundabout in a single stream. They can be a compact and low cost solution to improving junction capacity and an alternative to traffic signals.

6.70.2 Three arm, and some of the quieter four arm, roundabouts are relatively safe, but busier four arm, and combinations of double roundabouts may be uncomfortable and less safe from a cyclist's perspective.

### 6.71. Compact (or “Continental”) roundabouts DE055

6.71.1 Compact (or Continental style) roundabouts, which are included in TD16 of the DMRB, have tighter geometry that is more cycle friendly than conventional UK roundabouts. As the geometry encourages lower speeds, cyclists generally pass through the roundabout with other traffic, in the primary position. Motorists are unlikely to attempt to overtake cyclists on the circulatory carriageway because of its limited width. Compact roundabouts will have a lower traffic capacity than conventional roundabouts, and can be assessed using standard traffic analysis tools such as Arcady.

6.71.2 Compact roundabouts have arms that are aligned in a radial pattern, with unflared, single lane, entries and exits, and a single lane circulatory carriageway. Deflection is therefore greater and the design can be used as an effective speed reducing feature.

6.71.3 This design of roundabout is more common in mainland Europe than in the UK, but the principles applied in the geometric design of them improve conditions for cyclists and can be applied to solutions in the UK. Compact roundabouts are suitable for speed limits up to 40mph.

6.71.4 At busier compact roundabouts, consideration can be given to providing an external cycle track around the junction, and with Parallel Cycle/ Pedestrian Crossings\* across the entry and exit arms.

**Photo 6.38 – Compact Roundabout, Waltham Forest, London**







## 6.72. Conventional UK roundabouts

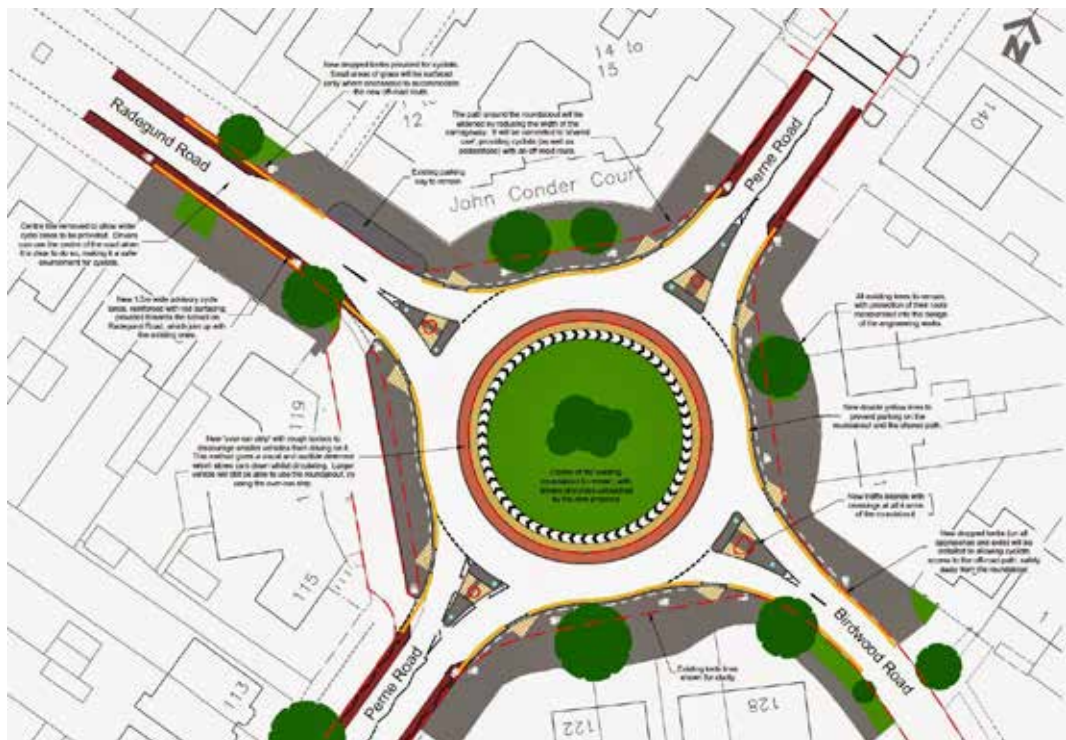
6.72.1 As noted above, conventional UK roundabouts (referred to in DMRB TD16 as Normal Roundabouts) with multi-lane flared approaches and wide circulatory carriageways are generally unsuitable for on-carriageway cycling and so no Design Element has been provided. Conventional roundabouts of this type should not feature on active travel routes unless suitable modifications are made.

6.72.2 Where a cycle route runs through a conventional roundabout options to consider are:

- redesign to a compact layout (see above), with reduced traffic capacity
- provide segregated cycle tracks with Toucan, or Parallel Cycle/Pedestrian Crossings\* on each arm
- introduce signal control to the roundabout, with appropriate cycle facilities
- replace roundabout with traffic signals, with appropriate cycle facilities

6.72.3 In Cambridge and in Oxford, existing conventional roundabouts are being re-engineered with narrower approach lanes and circulatory carriageways in order to improve conditions for cycling – see Image 6.39 below.

**Image 6.39 - Conversion of existing conventional roundabout to compact roundabout, Cambridge**



**Photograph 6.39 - Compact roundabout, Cambridge, as built**



6.72.4 Where such facilities or redesign is not feasible and a peripheral cycle track does not afford adequate priority to cyclists, an alternative active travel route should be explored.

### **6.73. Informal roundabouts**

6.73.1 Some authorities have installed junctions that are designed to encourage drivers to adopt circulatory priority, but they are in fact uncontrolled junctions, with no formal road markings or signs. Some Informal junctions (see Section 6.53 above) are designed with circular paving patterns to operate this way.

6.73.2 These have been found to work well in capacity and road safety terms at relatively high flows, of up to around 2500 vehicles per hour.

6.73.3 The use of circulatory patterns is appropriate where there is a high proportion of turning traffic, which would otherwise tend to give way to oncoming traffic in the centre of the unmarked space.

6.73.4 In terms of cycling, this type of junction can work well as long as care is taken to ensure that vehicles only circulate in one traffic stream and travel slowly, so that cyclists can adopt a primary position when passing through the junction, in a similar way to the compact roundabout.

## Key References

Cardiff Council (2011) Cardiff Cycle Design Guide

Chartered Institution of Highways and Transportation (2010) Manual for Streets 2

CROW (2007) Design Manual for Bicycle Traffic

Department for Transport (1993, TAL9/93 Cycling in Pedestrian Areas

Department for Transport (1995) The Assessment of Pedestrian Crossings, LTN 1/95

Department for Transport (1995) The Design of Pedestrian Crossings, LTN 2/95

Department for Transport (1998) Guidance on the Use of Tactile Paving Surfaces

Department for Transport (1998) TAL 6/98 Contraflow Cycling

Department for Transport (2001) Home Zones – Planning and Design, Traffic Advisory Leaflet 10/01

Department for Transport (2002) Inclusive Mobility: A Guide to Best Practice on Access to Pedestrian and Transport Infrastructure,

Department for Transport (2002) Home Zones – Public Participation, Traffic Advisory Leaflet 8/02

Department for Transport (2006) Mini-roundabouts, Good Practice Guide, CSS

Department for Transport (2007) Guidance on the use of Tactile Paving Surfaces

Department for Transport (2007) Manual for Streets, London

Department for Transport (2007) Local Transport Note 1/07: Traffic Calming

Department for Transport (2008) Traffic Management & Streetscape, LTN 1/08

Department for Transport (2008) Mixed Priority Routes: Practitioners' Guide, LTN 3/08

Department for Transport (2008) Cycling Infrastructure Design, LTN 2/08,

Department for Transport (2012) Shared Use Routes for Pedestrians and Cyclists, LTN 1/12

DPTAC (2010) Guidance on home zones - designing for disabled people  
Guide Dogs, Inclusive Streets



HA (1993) TD36/93 Subways for Pedestrians and Pedal Cyclists  
HA (2004) BD29/04 Design Criteria for Footbridges  
HA (2005) TD27/05 Highway Cross-Sections and Headroom  
HA (2007) TD54/07 Design of Mini-roundabouts  
HMSO (1997) Zebra, Pelican and Puffin Pedestrian Crossings Regulations and General Directions  
HMSO (2002) Traffic Signs Regulations and General Directions,  
Institute of Highway Engineers (2002) Home Zone Design Guidelines  
CIHT (2000) Guidelines for Providing for Journeys on Foot, Joint Statement on shared surface streets  
National Federation of the Blind (2013), Access for Blind People in Towns  
Sustrans (2011) The Merits of Segregated and Non-Segregated Traffic-Free Paths, Phil Jones Associates  
Sustrans (2012) A Guide to Controlling Access on Paths  
Sustrans (2014) DIY Streets Toolkit (Currently in the course of preparation)  
Sustrans Technical Information Note 17 Cyclists' Use of Zebra Crossings.  
Sustrans Technical Information Note 23 Road Safety Audits  
Sustrans Technical Information Note 30 Parapet Heights on Cycle Routes  
TfL (2014) London Cycling Design Standards (Currently in Draft)  
TfL (2011) Design Standards for Signal Schemes in London



Llywodraeth Cymru  
Welsh Government

# Part C

Related Matters



# 7 Integration with Other Modes

This Chapter provides guidance on how active travel should be integrated with other modes of transport – primarily public transport.

## 7.1. Introduction

- 7.1.1 Although most journeys are relatively short, and many could be entirely made by walking and cycling, longer journeys can also include an element of active travel by including a stage of public transport. Integration between walking, cycling and public transport can help to reduce dependence on private car use for longer journeys and maintain access to distant employment, services, friends or relations, for those without access to cars.
- 7.1.2 The better integrated public transport stops or interchanges – whether rail or bus, taxi or ferry – are with walking and cycling, the more efficient access to and from the interchange will be, improving the competitive advantage of both modes of transport. This will help to boost passenger numbers, while reducing motor traffic levels near the interchange, where pedestrian and cycling flows are likely to be high. Integration therefore represents a beneficial way of sustaining walking and cycling levels while reducing levels of both local and long distance car traffic.
- 7.1.3 Active travel already accounts for a significant proportion of journeys to public transport stops, although there is scope to increase cycling substantially. Compared with walking, cycling increases the 20 minute travel time catchment area to a stop by a factor of around 16, thereby greatly extending the reach of public transport. Improving cycle access to interchanges is therefore a major opportunity to generate new trips or shift trips from car to sustainable modes.
- 7.1.4 Presently some 45% of passenger journeys by rail in Wales access the station on foot, whereas just 2.7% arrive by cycle. Driving, either parked or dropped off, accounts for about 20% of journeys to rail stations[i].

## 7.2. Improving walking to public transport stops and interchanges

- 7.2.1 Access to stations on foot requires well signposted, high quality walking routes that are well lit, feel secure, are maintained properly and offer direct access from all directions in the surrounding area. Public transport interchanges should be considered a very high priority in the planning of the pedestrian network, following the guidance contained in Chapter



5. It may also be necessary to change the location of bus stops, or to introduce new ones, to reduce walk distances and improve accessibility, particularly where new development is planned.

7.2.2 Bus stops should be safe and comfortable to use and their siting and related pedestrian desire lines should be considered carefully, so that they can be easily accessed on foot by people of all abilities. Their precise location will depend on a range of issues, such as the need to avoid noise nuisance, visibility and other road safety requirements, and the convenience of pedestrians and cyclists. Footways at bus stops should be wide enough for waiting passengers while still allowing for pedestrian movement along the footway. This may require local widening of the footway at the stop.

7.2.3 Within the interchange itself facilities should be accessible to all users, with navigation to facilities clearly signed. Facilities, such as seats, shelters, left luggage, toilets and shops will make walking a more comfortable, attractive and therefore viable mode.

### 7.3. Improving cycling to public transport interchanges

7.3.1 To increase cycling to public transport, interchanges must be well connected to the cycle network, with well-signed, high quality routes linking to other major destinations and residential areas.

7.3.2 Access within the interchanges themselves need to be accessible for people with cycles, with step-free well signed access. Where lifts are required these should be capable of accommodating full size cycles, including those adapted for use by disabled people.

7.3.3 Cycle parking at public transport interchanges is covered in Section 8.9.

### 7.4. Carriage of cycles on public transport vehicles

7.4.1 Although it is not a requirement of the Active Travel Act, there are significant benefits to enabling public transport vehicles to accept cycles, and local authorities should encourage bus and rail operators to do so where feasible.

7.4.2 This is the case even if peak flows mean that restrictions on cycle carriage would be difficult at all times - public transport vehicles will be used at peak loading for less than a quarter of the time. Outside those hours more efficient use of the vehicles can be obtained by admitting a wider range of users, including those who wish to carry cycles with them.





**Photo 7.1 – Loading cycles onto a bus**



- 7.4.3 For many years the Snowdon Sherpa bus route has included provision to carry bikes on board, and similar schemes operate on bus routes in remote areas elsewhere in the UK.
- 7.4.4 Current regulations ensure that dedicated space is made available for wheelchair users on all public transport vehicles. However, many people with disabilities use cycles as mobility aids, and often need to carry cycles with them. Spaces made available for wheelchair users should be used flexibly when not required by wheelchair users, with clear instructions for priority usage for wheelchair users. While not commonly applied in Britain, such an approach can be used under international regulations which govern provision of wheelchair spaces on trains.[ii]
- 7.4.5 Taxis are part of the public transport system and providing mountable racks for cycle carriage will provide a useful facility for some longer trips – for example where the trip to a station is too long or busy to be cycled, and the passenger plans to make a cycle trip at the destination. Any mountable racks must maintain visibility to taxi licence plates.

**Photo 7.2 – Cycle rack on taxi in Copenhagen**



- 7.4.6 Although dwell times of public transport vehicles are usually little affected by cycle carriage, clear direction and signs both at interchanges and on vehicles will help show users where they should be expected to stand in order to board with their cycles, reducing inconvenience to other passengers and operators.

## **7.5. Cycle hubs and facilities at interchanges**

- 7.5.1 As well as being part of many inter-modal journeys, interchanges between multiple forms of public transport are often transport destinations in their own right. Provision of facilities to store cycles securely at stations (see Chapter 8) must therefore meet the needs of a range of different users, including those employed at the interchange, short term visitors, as well as longer term users who are using the interchange for daily journeys involving a cycling stage to or from the station.
- 7.5.2 At busier stations, secure cycle parking facilities with hire, repair and retail facilities are encouraged, with local authorities working in partnership with relevant organisations and operating companies. They may require subsidy, however, at least during the early stages of operation.

- 7.5.3 At major stations, and in locations where tourism potential is greatest, provision of cycles for hire can help to reduce onward private motor travel and support local accessibility.
- 7.5.4 Cycle hire can take the form of part of a wider cycle hire network, as part of a 'Cycle Hub', or provided as part of a standalone, or seasonal business. Some of these systems, such as the Brompton Dock, can offer cycles for hire on an automated basis, which eliminates the need for staff overheads.

#### **Case study – Leeds cyclepoint**

Leeds railway station is the third busiest station outside London, accommodating over 25m passengers a year. In 2010 a cycle hub was opened at Leeds station, based on Dutch experiences. The facilities provide secure storage for 300 bikes, hire and repair facilities. It is accessible to users with swipe cards for 18 hours a day, and staffed for 12.



### **7.6. Park and Cycle**

- 7.6.1 Park and Cycle works in the same way as a Park and Ride but with cycles taking the place of the bus or rail journey stage. Users can travel to the Park and Cycle area by car and park their vehicle, take out their bike from an individual locker and cycle the rest of the way to their destination. Equipment such as clothing and helmets can be stored in the lockers. In order to maximise viability the pricing strategy has to allow for payment for parking, in addition to a fare on any associated bus or train service.
- 7.6.2 A Park and Cycle site has been operating at the University of Cambridge since 2001 – see <http://www.admin.cam.ac.uk/offices/em/travel/cycle/park.html>

## References

[i] Figures for journeys commencing at stations operated by Arriva Trains Wales from Waves 16-22 of the National Passenger Survey (Passenger Focus).

[ii] European Commission decision of 21/12/2007 “concerning the technical specification of interoperability relating to ‘persons with reduced mobility’ in the trans-European conventional and high-speed rail system”

[iii] Green C & Hall P, Better Rail Stations: An Independent Review Presented to Lord Adonis, Secretary of State for Transport. 2009

## 8 Related Facilities

This Chapter provides guidance on the design of important related facilities for walking and cycling, including seating, cycle parking and direction signing. It provides guidance in relation to Section 2(9) of the Active Travel Act. In determining whether anything constitutes related facilities for the purposes of this Act a local authority must have regard to this guidance.

### 8.1. Introduction

8.1.1 Section 2 (8) of the Active Travel Act defines a range of features as related facilities for the purposes of the Act including:

- a) facilities for shelter, resting or storage,
- b) toilets or washing facilities,
- c) signing, or
- d) other facilities, which are available for use by, or by any description of, walkers and cyclists using the active travel route.

8.1.2 As noted in Chapter 4 walking and cycling have many similarities and yet they have different user needs. This also applies for related facilities; cyclists will require facilities for showering and secure locations to leave their cycle whilst pedestrians will require seating and shelter to rest. Both pedestrians and cyclists will require clear direction signing, whilst well maintained planting and public art can contribute to visual amenity.

### Related Facilities for Walking

#### 8.2. Introduction

8.2.1 Related facilities are key to making streets more attractive and tools such as Community Street Audits can be used to assess the needs of local communities for specific related facilities.

8.2.2 They can be divided into five broad categories:

- seating;
- public toilets;
- pedestrian signing;
- planting
- litter bins

### 8.3. Seating

- 8.3.1 Seating points for pedestrians, particularly those with mobility or visual impairments, should be provided at intervals along active travel routes. Seating is also important for the activity and vibrancy of public spaces.
- 8.3.2 The requirement will be dictated by local need. In busy pedestrian areas and key routes where older and disabled people are more likely to use them, resting places should be provided at intervals of around 50m as recommended in Inclusive Mobility. Elsewhere a figure of 100m is appropriate as recommended in Manual for Streets.
- 8.3.3 Extra seating should be considered where people congregate, such as at squares, local shops and schools. The provision of seating encourages a range of 'place' activities to take place in public space including eating, reading and watching and meeting people.
- 8.3.4 Guidance on the design and layout of inclusive seating is given in Inclusive Mobility and BS 8300. In addition to standard height seating, lower seats are useful for people of small stature and children; and higher perches (700mm) against which people half lean and half sit are useful for some disabled people.
- 8.3.5 Seating such as benches should include space for wheelchair users to sit alongside companions and be located so that when people are seated their feet are not in the pedestrian route, and designed so that people can easily sit and rise from them. BS 8300 recommends the clear space for access to seating designated for disabled people should be 1.05 metres by 2.3 metres deep to allow for manoeuvring a wheelchair into a designated space from a circulation route at right angles.
- 8.3.6 Seating should ideally be located where there is good natural surveillance and lighting to deter anti-social activity. Seating should allow for street activities to be viewed and can be used to demark areas although its location should not hinder circulation of pedestrians or form an obstruction to movement. Seating can be laid out in various ways:
- inward looking, to encourage conversation;
  - outward looking, to see the views;
  - in the centre of activities, for rest and chance meetings;
  - at bus stops, for waiting (ideally covered);
  - in secluded corners, integral with planting.
- 8.3.7 Materials should use visual contrasts and reflect the theme for other



street furniture, but should allow for comfort (including backs and armrests) stability, maintenance, and should consider potential for vandalism, anti-social behaviour and the effects of adverse weather. In addition to seating such as benches consideration should be given for supplementary secondary seating such as stairways, pedestals, low walls, and boxes to meet times of peak demand such as lunch times. Steps built within public spaces are particularly popular because they can serve as a good lookout point as well.

## 8.4. Public toilets

- 8.4.1 A lack of clean, accessible and safe toilets impacts on all pedestrians but can disproportionately affect the most vulnerable pedestrians. Older people, parents and carers with young children, disabled people and people with chronic health problems all need easy access to suitably equipped public toilet facilities. Some people may feel unable or reluctant to leave their homes and visit areas where they fear they will not be able to find a public toilet.
- 8.4.2 Public toilets in places like parks and promenades help to encourage people who may need regular toilet access to take exercise and stay physically active. However, public toilets that are badly designed, badly maintained, and poorly located generate a sense of neglect.
- 8.4.3 Toilets should be no less available for disabled people than for non-disabled people. It is recommended that disabled toilets should be designated as unisex, not integrated with male and female toilets. The provision of unisex toilets allows use by disabled people accompanied by a carer or partner of the opposite sex.
- 8.4.4 Further guidance regarding toilet design and minimum specifications can be found in Inclusive Mobility and BS8300. Changing places in toilet facilities which are larger than accessible facilities and are equipped with benches and hoists to enable carers to assist severely disabled people should be provided at key locations such as transport hubs, with the co-operation of partner organisations. Further information is available at <http://www.changing-places.org>



## 8.5. Pedestrian Signing

8.5.1 Signing is an important related facility for pedestrians to help people find their way around. High quality, well placed and clear bilingual signing is vital to ensure pedestrians are sufficiently aware of the most direct route to local facilities. Signing should complement the surrounding environment and be considered at the route or network scale to ensure consistency.

8.5.2 Signing with, where appropriate, tactile embossed signs and Braille should be clear and give pedestrian users who may not be familiar with the local area some indication of distance and/or time (although will vary according to the walking speed of the individual) to local facilities. Destinations for pedestrian signing could include:

- public transport nodes
- libraries
- post offices
- sports stadiums
- leisure centres
- parks
- main office locations and business parks
- religious buildings
- hospitals
- shopping centres
- educational establishments
- cultural institutions
- tourist advice centres
- tourist and leisure attractions
- recreational walking and cycling routes
- cycle maintenance and repair shops

8.5.3 It is important to prevent excessive signing contributing to the accumulation of street clutter. Most people will be aware of facilities close to their home but pedestrian signing can be particularly useful where:

- people may not be aware of a walking route to local facilities within walking distance leading them to use the car instead;
- if they are new to the area;
- there are likely to be tourists and visitors unfamiliar with a location (such as town and city centres)

8.5.4 Way finding signing such as the on-street maps used in Cardiff or Newport are good examples of signing which fit well within the existing street environment, and are provided at places where significant numbers of travellers unfamiliar with the area arrive, such as outside train stations. Tactile versions of these maps combined with audible information can be useful in some situations. Consideration should also be given to supplying tactile maps and/or audio trails.

**Photo 8.1 – Cardiff wayfinding scheme**



**Photo 8.2 – Cardiff pedestrian signing**

- 8.5.5 Signing should be frequent and continuous along the entirety of a walking route and integrate within wider walking networks. It is normally provided via finger posts, which can be in a variety of styles. Signing for pedestrians normally provides information on walking distances. Whilst walking times can be useful it is important to consider that walking times can vary significantly from person to person.
- 8.5.6 An alternative to above ground signing is to incorporate directional indications into the footway itself, using special paving slabs or plaques to identify particular walking routes, including the use of shared use signs to TSRGD Diagram 956, although these contain no directional information. This may also provide useful guidance for some vision impaired people. However, this will only be useful to those people with sufficient residual vision as generally the signs do not have sufficient distinctive texture to be identified underfoot or by cane and for their meaning to be recognised. Tactile guidance paths are useful for blind pedestrians, as specified in the UK Department for Transport Guidance on the use of tactile paving surfaces. Further guidance regarding accessible signing can be found in Sign Design Guide – a guide to inclusive signing, published by the Sign Design Society, <http://www.signdesignsociety.co.uk>

- 8.5.7 Street name plates in a consistent style in each local authority area are also valuable navigational aids. They should generally be located at or below 2.5m height, although this may not always be practical. They should be provided at both ends of every street (except culs-de-sac). On long streets (where pedestrians are likely to join the street mid-block) they should also be provided at junctions with side roads; and building numbers should be included on name plates. Where practical on wide streets, name plates on both sides would be desirable.
- 8.5.8 It is important that signed walking routes are as direct as possible as pedestrians will not accept long detours. However, people should not be directed via inappropriate, unsafe or poor quality routes just because they are the most direct – this will do little to encourage walking activity and will reflect poorly on an area particularly for first time visitors.

## 8.6. Planting

- 8.6.1 Planting delivers a number of benefits for pedestrians and other street users and brings to life any streetscape. Trees and planting can provide a valuable barrier between pedestrians and vehicles, enhancing pedestrian safety and comfort. Planting can provide shade, shelter, privacy, spatial containment and separation. It can also be used to create buffer or security zones, visual barriers, or landmarks or gateway features. Vegetation can be used to limit forward visibility to help reduce vehicle speeds.
- 8.6.2 It can help to soften the urban street-scene, create visual and sensory interest, and improves the air quality and microclimate. It can also provide habitats for wildlife. The aromatic qualities or contrasting colours and textures of foliage are of value to all, and can assist the navigation of those with visual impairment. Flowers and fruit trees add seasonal variety.
- 8.6.3 However, vegetation needs to be planted in appropriate locations and in the right manner. Trees and shrubs sited within or close to footways should be carefully selected so that their spread does not reduce pedestrian space below minimum dimensions for width and headroom and do not obstruct pedestrian sight lines. Low overhanging trees and overgrown shrubs can be particularly hazardous for blind or partially-sighted people and it is recommended that projections and overhanging trees must leave a minimum headroom of 2.1 metres.

**Photo 8.3 – Poorly maintained tree obstructing footway**

- 8.6.4 To ensure its long term viability of any planting will require the provision of:
- healthy growing conditions;
  - space to allow growth to maturity with minimal intervention or management;
  - species appropriate to a local sense of place and its intended function, and site conditions; (for example avoid plants where dropped leaves can become a slip hazard);
  - suitable arrangements for long-term maintenance. In new developments these proposals should be agreed with the adopting local or highway authority, trust, residents' or community association or management company.
- 8.6.5 Space for planting can be integrated into layout and building designs, located on private land or buildings (in generous balconies, roof gardens, and walls) or public land intended for adoption, including the highway.



- 8.6.6 Careful consideration needs to be given how vegetation is planted. Trench planting, irrigation pipes and urban tree soils will increase the chance of trees establishing themselves successfully, thereby minimising maintenance and replacement costs. Consideration should also be given to the potential impact of planting on adjacent buildings, footway construction and buried services. Planting should be capable of regeneration or easy renewal if vandalised and should be designed for minimal maintenance. Further advice on planting in streets and other hard paved areas is given in *Trees in Hard Landscapes: a Guide for Delivery*, published in 2014 by the Trees & Design Action Group. <http://www.tdag.org.uk/trees-in-hard-landscapes.html>
- 8.6.7 Where trees and other shrubs cannot be planted directly into the ground, containers can be used. Larger containers will be more appropriate in pedestrian areas. The positioning of planters should be an integral part of the design of the open space. Their size, position and colour must also take into account the needs of the visually impaired and in all cases a safe width for the through passage of pedestrians should be maintained. It is important that on-going maintenance is considered to prevent the potential accumulation of litter in planters.

## 8.7. Litter Bins

- 8.7.1 Litter bins are important to ensure walking routes remain comfortable and attractive. Research undertaken by Living Streets in 2012 revealed that 76% of Welsh adults when asked about the area they live in had seen litter or dog fouling on their local street.
- 8.7.2 Litter bins should be clearly identifiable and located where they are likely to be used. For example, a litter bin placed outside the entrance to a fast food shop may be less effective than one placed 200 metres away where the food and packaging litter tend to be deposited.
- 8.7.3 Litter bins should have sufficient capacity for their expected use and local authorities and private owners responsible for their maintenance should ensure they are emptied on a frequent basis. The design of litter bins should be carefully considered. Plastic bins can suffer damage in some locations while metal bins corrode quickly in saline environments. Open topped bins are prone to having litter escape from them whilst closed top bins should be regularly cleaned to encourage usage.
- 8.7.4 Inclusive Mobility and BS8300 provide useful guidance regarding the need to ensure bins do not become an obstruction by considering their location, design, height, use of visual contrast strips and ensuring they do not project from posts.

## Key References

British Standards Institute (BSI) (2010) BS 8300: 2010 Design of Buildings and their Approaches to Meet the Needs of Disabled People

Chartered Institution of Highways and Transportation (2000) Guidelines for providing for journeys on foot

Department for Communities and Local Government (2006) Tree Roots in the Built Environment

Department for Transport (2007) Manual for Streets

Department for Communities and Local Government (2008) Improving Public Access to Toilets – A strategic guide

Department for Environment, Food and Rural Affairs (2005) Achieving improvements in street cleansing & related services

Department for Transport (2002) Inclusive Mobility A Guide to Best Practice on Access to Pedestrian and Transport Infrastructure

Chartered Institution of Highways and Transportation (1999) Planning for Public Transport in Developments

Living Streets (2004) Designing Living Streets

Sign Design Society and the Royal National Institute of Blind People (2000) Sign Design Guide – a guide to inclusive signage

Tree and Design Action Group (2014) Trees in Hard landscape: A Guide for Delivery



## Related Facilities for Cycling

### 8.8. Introduction

8.8.1 The provision of good related facilities will encourage cycling and typically delivers excellent value for money. Many facilities, such as cycle parking and signing, can be provided without significant change to other infrastructure or the requirement for a lengthy approvals process.

### 8.9. Cycle parking

#### Overview

8.9.1 The availability of appropriate cycle parking facilities at either end of a trip has a significant influence on the decision to travel by cycle. The absence of such facilities, and the consequent risk of vandalism and theft, has been shown to undermine investment in the overall network infrastructure.

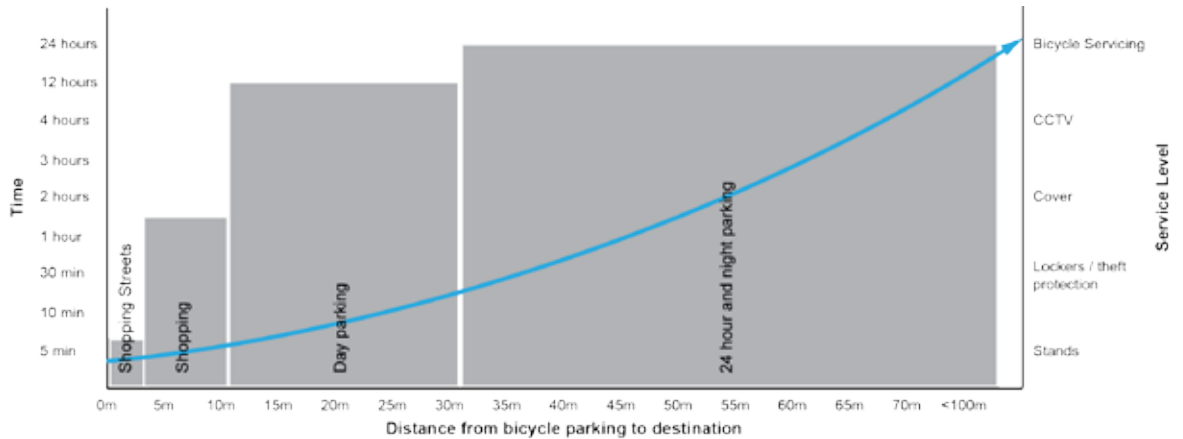
8.9.2 Cycle parking is therefore integral to any cycle network, but it can also precede other dedicated cycle infrastructure, in order to address the cycle parking needs from the outset. Cycle parking is also a key part of providing integration with public transport allowing cycling to act as a feeder service to public transport routes, as discussed below.

8.9.3 The quantity and type of cycle parking that is appropriate differs between locations. Consideration of the different needs of each setting is therefore important. Five broad location categories for types of cycle parking can be defined:

- retail;
- employment;
- leisure and public institutions; and
- residential;
- public transport interchanges.

8.9.4 Cyclists generally want to park as close to their destination as possible, for this reason and to reinforce the transport hierarchy, cycle parking should be sited as close as possible to the final destination or main access of buildings. Experience suggests that where this is not the case cyclists are likely to 'fly park' (park informally) in more convenient locations. Figure 8.1 gives guidance on the relationship between proximity of cycle parking to the final destination and the duration as well as service level features, chiefly related to weather protection and security that might be appropriate for each setting.

**Figure 8.1: Relationship between cycle-parking type, location and security facilities**



**Quantity of Cycle Parking**

- 8.9.5 The required quantity of cycle parking should be carefully assessed. There should be adequate parking to meet demand including some spare capacity to allow for growth in cycling whilst avoiding cluttering the streetscape and affecting the space available for walking and cycling routes.
- 8.9.6 The quantity of cycle parking will be dependent on the location and nature of provision. Some local authorities provide specific guidance on cycle parking requirements, but in its absence Table 8.1 proposes appropriate minimum cycle parking levels. Where the land use under consideration does not correspond to those detailed in Table 8.1 a decision should be made based on the setting and evidence of current demand for cycle parking locally.

**Table 8.1: Minimum cycle parking standards**

Land use type	Sub-category	Short Stay requirement (obvious, easily accessed and close to destination)	Long stay requirement (secure and ideally covered)
Retail	Small (<200m <sup>2</sup> )	1 per 100m <sup>2</sup>	1 per 100m <sup>2</sup>
	Medium (200-1,000m <sup>2</sup> )	1 per 200m <sup>2</sup>	1 per 200m <sup>2</sup>
	>1,000m <sup>2</sup>	1 per 250m <sup>2</sup>	1 per 500m <sup>2</sup>

Employment	Office/Finance (A2/B1)	1 per 1000m <sup>2</sup>	1 per 200m <sup>2</sup>
	Industrial/Warehousing (B2/B8)	1 per 1,000m <sup>2</sup>	1 per 500m <sup>2</sup>
Leisure and Institutions	Leisure centres, assembly halls, hospitals and healthcare	Greatest of: 1 per 50m <sup>2</sup> or 1 per 30 seats/ capacity	1 per 5 employees
	Educational Institutions		Separate provision for staff and students.  Based on Travel Plan mode share targets, minimum:  Staff: 1 per 20 staff  Students; 1 per 10 students
Residential	All except sheltered/elderly housing or nursing homes	-	1 per bedroom
	Sheltered/elderly housing/nursing homes	0.05 per residential unit	0.05 per bedroom
Public Transport Interchange	Standard stop	Upon own merit (see below)	
	Major interchange	1 per 200 daily users	

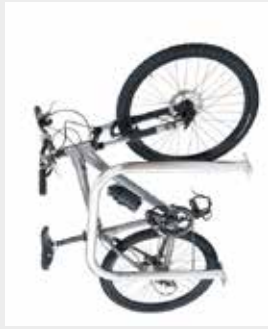
C

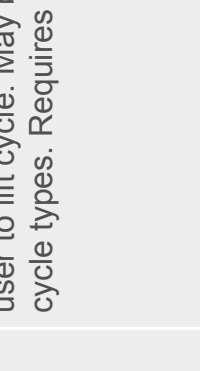
- 8.9.7 Where cycle parking is already provided, or there is evidence of demand for cycle parking from cycles secured to street signs or other street furniture, monitoring by periodic survey can be a valuable tool in establishing demand and where cycle parking should be provided or added to.
- 8.9.8 Wherever demand is close to supply of available spaces, it is likely that there is suppressed demand. If cycle provision is already high (over 50 spaces provided), capacity should be increased by at least 20%.

### **Types of Cycle Parking**

- 8.9.9 Just as the location, layout and quantity of cycle parking should be considered in the context of its use so should the nature of the cycle parking equipment itself. Different types of cycle parking offer different characteristics in terms of their ease of use, weather protection, security and space requirements. Table 8.2 sets out a range of cycle parking types and gives guidance on where these might be appropriate. Where there is more than one tick, the parking type is particularly suitable. In general, well designed cycle parking systems (such as the Sheffield Stand) will allow both the frame and wheels to be secured.

Table 8.2: Range of cycle parking types

Type	Location Type						Notes
	Retail On-street	Retail Off-street	Employment	Leisure, Schools etc	Residential	Public Transport Stop/ Station	
Sheffield Stand 	✓ ✓	✓ ✓	✓	✓ ✓	✓	✓	Flexible solution provides secure locking for a variety of cycles. Reasonably priced and available in a variety of finishes, multiple formats and shape variations. Well-spaced stands allow two cycles to be parked at each stand. May be combined with baseplates to form a 'toastrack'.
Street Stands 	✓ ✓	✓	✗	✗	✗	✗	More compact but less stable/locking points than a Sheffield stand. Suit a variety of cycle types.

<p>Vertical Stand</p> 	<p>✗</p>	<p>✗</p>	<p>✓</p>	<p>✗</p>	<p>✓</p>	<p>✗</p>	<p>✓</p>	<p>✗</p>	<p>✗</p>	<p>Compact space requirement but often requires user to lift cycle. May be incompatible with certain cycle types. Requires secure locking point.</p>
<p>Two-tier stand</p> 	<p>✗</p>	<p>✓</p>	<p>✓</p>	<p>✗</p>	<p>✓</p>	<p>✓</p>	<p>✓</p>	<p>✓</p>	<p>✓</p>	<p>Suitable for locations where very high levels of cycle parking are required in confined spaces. Some users may find lifting cycle to upper tier difficult.</p>
<p>Lockers/Cages</p> 	<p>✗</p>	<p>✗</p>	<p>✓</p>	<p>✗</p>	<p>✓</p>	<p>✓</p>	<p>✓</p>	<p>✓</p>	<p>✓</p>	<p>High security but time-consuming to use and with high-space requirement. Best suited to long-stay parking. Likely to require maintenance.</p>

<p>Wheel stands</p> 	✓	✓	✗	✓	✗	✗	<p>Compact footprint but should include facility to stabilise and lock the cycle frame to the stand. Can be incompatible with some cycles/ wheels. Stands that support cycles only by the wheel can cause damage to cycles and are subsequently often not used.</p>
<p>Wall Fittings</p> 	✓	✓	✗	✓	✗	✗	<p>More compact but less stable/locking points than a Sheffield stand. Suit a variety of cycle types.</p>
<p>Street furniture retrofit</p> 	✓	✓	✗	✗	✗	✗	<p>Compact space requirement but often requires user to lift cycle. May be incompatible with certain cycle types. Requires secure locking point.</p>



### Cycle parking at interchanges

- 8.9.10 Providing adequate space for cycle parking at bus, rail or ferry terminals is vital and should be given a high priority by authorities, working in partnership with the relevant operators and organisations managing the facilities.
- 8.9.11 A careful assessment of demand will be necessary. Where cycle parking already exists, regular counts of parked cycles will give an indication of any excess demand or current spare capacity. Counts should be undertaken in good weather at a range of times during the day. Where 'fly parked' cycles (cycles parked in locations that are not within the designated parking areas) can be found, this will give an indication that the existing parking provision is:
- insufficient to meet demand
  - not secure enough to provide confidence to users
  - too far from the entrance to the interchange or station
- 8.9.12 When evaluating demand, the nature of public transport trips and the direction of travel should be taken into account. Outlying stops and stations that serve daily commuters travelling by bus or train to town or city centres are likely to have a demand which is greater than termini or interchanges. For commuter stations in particular, demand for cycle parking should be provided based on the future anticipated cycle mode share. It is recommended that a starting point of 5% of passengers entering the station should be assumed, based on Better Rail Stations report, prepared for the Department for Transport.<sup>3</sup>
- 8.9.13 Secure cycle parking can also be provided in small quantities at suburban and rural bus stops, which will greatly increase their catchment area.

**Note 3 Green and Hall (2009). Better Rail Stations – An Independent Review. London: Department for Transport**

**Photo 8.4 – Secure cycle parking at suburban bus stop, Nantes, France**



- 8.9.14 Security of cycle parking at interchanges can be improved with better lighting, CCTV, and the provision of specific equipment such as lockers, or secure cycle storage compounds. In some locations local authorities, in partnership with rail operators, are introducing ‘Cycle Hubs’ which combine secure cycle storage with retail and hire facilities, as discussed in Chapter 7.

#### **Cycle Parking Layout and Other Requirements**

- 8.9.15 Cycle parking should, as a minimum, be large enough to accommodate the dimensions of a typical adult size cycle, as given in Chapter 4. Increased space provision may be required in locations where large cycles or cycles with goods baskets or child seats are expected to park frequently. In all cases the location of cycle parking should ensure that parked cycles will not obstruct nearby walking and cycling routes.
- 8.9.16 Table 8.3 sets out the appropriate space allowances for the layout of cycle parking. Providing insufficient space is likely to result in the cycling parking being frustrating to use with subsequent lower use.

**Table 8.3: Space allowances for cycle parking**

Situation	Dimensions	Area per cycle
Stands on street	1.8m x 0.5m	1m <sup>2</sup>
Within building minimum	1.8m x 0.5m spaces plus 1.8m aisle	1.35m <sup>2</sup>
Within building generous	2.0m x 0.75m spaces plus 3 - 4m aisle	2–3m <sup>2</sup>

8.9.17 There are many ways of arranging cycle parking but in all cases the following should be considered:

- Security – Cycle parking must allow users to secure their cycle with a variety of lock types;
- Lighting – essential for personal security and for parking after dark;
- Weather protection – can the cycle parking be covered? This is important for commuters and overnight parking;
- Obstruction – The needs and space requirements of other users, particularly blind and partially sighted pedestrians must be considered and parked cycles should not obstruct these routes. Visual aids such as high visibility markings on the first and last stand in a row or contrasting colour/texture paving may be used to delineate cycle parking areas;
- Potential to integrate with existing street furniture, signing or planting;
- Located on level ground or, if this cannot be achieved, perpendicular to the slope to avoid cycles rolling down the slope; and
- Located in obvious, clean, maintained and overlooked areas to deter vandalism/theft, and to make users feel safe and welcome.

8.9.18 Cycle parking must be installed appropriately. In addition to the correct layout, the physical installation must be correct to minimise the chance of damage through regular use or the risk of vandalism and theft. Construction details will vary for different options

8.9.19 In on-street locations where space for cycle parking is limited, for instance constrained or busy footways, consideration should be given to the placing of cycle parking stands on the carriageway. This may require the reallocation of existing kerbside car parking.

8.9.20 Around eight cycles can be accommodated in the same space as one car parking space. The provision of multiple cycle stands in place of one or two car parking spaces demonstrates the space efficiency of cycling over car use and allows a greater number of people to park in busy areas. Care should be taken with such designs to minimise the risk of vehicles striking cycle stands or parked cycles - the stands will usually need to be protected through the construction of build-out extensions into existing carriageway space.

**Photo 8.5: Cycle parking in kerbside parking area**



### **Paid-for cycle parking**

8.9.21 In key urban locations such as transport interchanges and city centres it may be appropriate to provide paid cycle parking facilities (the cycling equivalent to a car park with charges). Such facilities in the UK (Leeds, London and Brighton) and on the Continent typically offer high numbers of cycle parking spaces.

8.9.22 The success of such facilities is likely to be related to the availability of unpaid nearby cycle parking and the range of additional related facilities offered such as:

- cycle hire;
- bicycle shop;
- on-site workshop; or
- showers and lockers.



8.9.23 Further information on these Cycle Hubs is given in Chapter 7.

## 8.10. Signing for Cycling

8.10.1 Road signs and markings fall into three categories:

- Regulatory – enforceable traffic management signing;
- Warning and advisory– traffic management signing and markings that are to warn of hazards and to guide positioning;
- Route guidance – location and direction signing.

8.10.2 Signing for cycling may combine more than one of these functions. All signing must be bilingual.

8.10.3 In addition to general traffic signing and road markings there are cycling-specific signs and markings in each of the three above categories. Cycle specific signing is useful to

- warn drivers to keep out of cyclists' space and assist enforcement;
- encourage lane discipline and safe positioning by drivers and cyclists;
- warn other road users of the likely presence of cyclists;
- publicise recommended cycle routes; and
- promote cycling and raise its status.

8.10.4 The design of all prescribed road signs (and road markings which are technically signs) must be undertaken in accordance with the requirements of the Traffic Signs Regulations and General Directions (TSRGD) and should accord with Chapters 3, 5, and 7 of the Traffic Signs Manual (DfT, 2008 and 2003a and 2003b). The advice here complements that guidance by expanding on some signing issues particular to the design of cycle infrastructure.

8.10.5 For non-prescribed signs (i.e. signs not included in TSRGD), authorisation is required before they can be used. In Wales this authorisation is given by the Welsh Ministers.

8.10.6 The amended edition of TSRGD published in 2011 made some important changes over the previous version. These included:

- A new sign for contraflow cycling without a cycle lane
- Introduction of 'Cyclists Rejoin Carriageway' sign, which was a variant of the 'Cyclists Dismount' sign with the aim of discouraging the use of the latter.





- 8.10.7 A revised version of TSRGD is currently under preparation, and the revision will include further additional cycle specific signing:
- Allowing an 'Except Cyclists' sign to be placed under the No Entry sign (diagram 616)
  - Low level cycle signals
  - The use of a red cycle aspect on cycle signals
  - The use of 1010 road markings through junctions
  - The use of 'Elephants Footprint' markings through traffic signal junctions
  - The removal of the need to place vertical cycle route signs to diagram 967 in association with the cycle symbol, diagram 1057
- 8.10.8 The design of cycle signing and wayfinding should consider the following key principles:
- **Minimising signing.** The potential to improve the clarity and safety of a route through improved design rather than extra signs;
  - **Minimising clutter.** The use of signing which minimises street clutter through appropriate scale, good location and integration with existing street furniture;
  - **Signing coherence.** The importance of coherent and consistent signing over a whole network and along a particular route;
  - **Maintenance.** Minimise the need and cost of future maintenance to ensure that safety and wayfinding remain of a high quality in the long term; and
  - **Value of signing.** Good signing should enable cyclists to locate themselves and the intended destination through use of strategic and local destination signing to include key facilities
- 8.10.9 Many signs are optional rather than mandatory. On the majority of on-street routes cyclists can be adequately catered for within the general traffic signing regime and by exemption to restrictions. It is useful to bear this in mind, as cycle infrastructure can be quite sign intensive and, if not carefully designed, can create unnecessary visual intrusion. Overuse of coloured surfacing adds to this. Where appropriate, signs should be mounted on walls, existing posts or other street furniture to minimise the number of sign posts on the footway.

### Route guidance, location, and direction signing

- 8.10.10 Route, location and direction signing creates a usable network for cycling. It communicates to people where it is possible to travel and in many cases how much more direct these options can be than the alternative car or public transport journey. They are also essential to direct and reassure people who are not familiar with the area. Not all signing used for cycling needs to be specific - well implemented standard signing such as street names and traffic signs provide a foundation on which to make specific additions.
- 8.10.11 Cycle routes are usually distinguished by white on blue vertical signing with a cycle symbol. Cycle route signing and route confirmation should only be used where routes are direct and convenient and where the journey experience, under normal conditions, is reasonably good.
- 8.10.12 Along off-highway routes and along back streets, general direction signing is unlikely to be present, and so cycle signs should address the requirements of direction signing as well as route confirmation. This can be done with signs or with road markings. On main road routes vertical signs should be used for direction signing, with a route symbol either on the sign or combined with lane markings to provide route confirmation.\*
- 8.10.13 In addition to marking the route itself, signs may be required to direct cyclists onto the route at intermediate locations. Signs may also be required to direct cyclists to destinations along the route or at the end. A specific locality e.g. Abercynon train station should be used even if the cycle route itself does not go all the way there.
- 8.10.14 Within each area a consistent set of destinations should be used, these will typically be divided into primary, local and supplementary destinations. Examples of these categories are given in Table 8.4.
- 8.10.15 Care should be taken with the design of sign assemblies to reduce the risk of vandalism and sign rotation. Where fingerpost arrangements are proposed, purpose built products are available which can provide aesthetically pleasing non-rotatable signs. Alternatively, rectangular posts should be used for cycle direction signs as these will help prevent rotation.



**Table 8.4: Example signing categories**

Primary	Local	Supplementary
Cardiff	Roath Butetown Cathays Splott Ely	Public Toilets Shopping centres Sports centre Railway stations Tourist attractions Named cycle routes e.g. Taff Trail, Celtic Trail
Newport	Malpas Rogerstone Duffryn Maindee	
Caerphilly	Bedwas Machen Energlyn Trecenydd	

8.10.16 It is also important to ensure signs are located where they will be visible and not obscured by other signs or vegetation growth.

**Types of direction signs**

8.10.17 There are a variety of types of direction sign, with factors depending on location and purpose. The main types are listed below. However, detailed sign design requires specialist traffic engineer input, reference to the Traffic Signs Manual and normally the use of appropriate computer software.

- Finger posts are used at the actual junction. The sign itself points in the appropriate direction and includes a chevron type arrow.
- Advance signs are used prior to junctions to give warning of the junction and enable initial manoeuvring to take place.
- Stack signs are where the different destinations are listed above each other in tabular form. They can be used as advance direction or prior to a junction.

- Map type signs are where a pictorial representation (map) is used on the sign to help clarify the direction of the destinations. Signs of this type are of value at complex junctions or where the route taken may be unclear.

**Photo 8.6: Finger posts, Finger Post and Stack Sign, Map sign**



### Route confirmation signs

- 8.10.18 On long sections of cycle route between nodes, there may be the need to erect route confirmation signs to let the users know that they have not left the route without being aware. The cycle route sign Diagram 967 on its own is not recommended for this as the cyclist could be on a different route from that desired.
- 8.10.19 Route confirmation signs should be provided at least every 1 mile, as well as after each decision point (normally at the far side of every junction).

### Off highway signs

- 8.10.20 Although the TSRGD only applies to public highways, in other locations consistency with these standards is recommended so that the meaning of signs is clear to all users. However, on such traffic-free routes there is greater flexibility to add character to routes through branding, integration with public art and use of symbols on bollards and posts. Any bespoke signs should not be similar to standard signs that comply with TSRGD, however.



## 8.11. Cycle hire and public bike systems

8.11.1 Cycle hire and public bike systems have been implemented in a number of locations over the past decade; notable examples are London, Paris and New York. Such systems can encourage more people to cycle without the need to bring one into the centre of the town or city, or even to own a cycle at all, and can raise the profile of cycling generally. Successful schemes typically cover a broad network of hiring stations enabling users to travel between a variety of destinations and could provide a significant enhancement to the active travel network

8.11.2 A successful hiring scheme will require the following:

- significant capital and operating cost funding or sponsorship for the medium to long term;
- hire stations at major destinations: transport hubs, retail centres and major workplaces;
- careful planning of the number and size of hiring stations based on user survey or a demand assessment;
- sufficiently comprehensive coverage to offer an option for point-to-point journeys;
- a dedicated team to look after cycle availability/roadworthiness and station tidiness; and
- appropriate technology and/or staffing to include means of securing and releasing cycles that can be understood by a range of users and which is reliable.

8.11.3 In addition to the larger well-known public schemes a number of private operators such as train companies are expressing an interest in providing cycle hire in a variety of locations (see Photo 8.6) These may offer an alternative to public schemes, or may be 'closed' schemes with memberships limited to a known set of users for instance a company workforce. Such private operators may also offer a wider variety of cycle types for instance folding or electric cycles.

**Photo 8.7 - Bike&Go at Rochdale Station, operated by Merseyrail**



Image courtesy of David Dixon

## 8.12. On-street maintenance facilities

8.12.1 Many cyclists will not have the space, knowledge, equipment or inclination to maintain their cycle. In order to encourage cycling and particularly the roadworthiness of cycles there may be the opportunity to offer facilities or assistance to encourage cycling. Examples of such facilities, illustrated in Photos 8.7 might include:

- pumps
- tools
- electric bike charging points
- on-street cycle services
- mobile cycle shops

**Photos 8.8 : On-street cycle facilities**



**8.13. Cycle Counters**

- 8.13.1 Cycle counters are equipment that is able to monitor the level of cycle use over time. The data gathered can aid the understanding of travel habits and aid in the planning and justification of providing for cycling. Further guidance on the potential role for cycle counters in monitoring and evaluation programmes is given in Chapter 11, including costs.
- 8.13.2 Cycle counters are often not visible to the public (Photo 8.8a) but a variation on this is to attach a public display to a counter in order to display the information in real-time (Photo 8.8b). Installation of counters such as this have been well received and have a valuable function in the promotion of cycling by indicating to the general public the importance placed on levels of cycling in an area.

**Photos 8.9 : Typical cycle counter for monitoring, Public cycle counter**





# 9 Creating, Improving and Managing Highways

This Chapter provides guidance to local authorities when carrying out their general duties and powers in connection with creating, improving, maintaining and managing public highways, whether or not they are defined as an active travel route.

## 9.1. Introduction

- 9.1.1 The weight to be given to the Guidance is greater for defined active travel routes, however, since under Section 7 of the Act authorities must in every year secure new and make improvements to existing active travel routes and related facilities. This will have implications for how authorities go about their general highway duties.
- 9.1.2 Common legal processes associated with the provision of active travel facilities are given in Appendix C.
- 9.1.3 Section 9(1) of the Active Travel Act states that the Welsh Ministers and local authorities must take reasonable steps, as far as it is practicable to do so, to enhance the provision made for walkers and cyclists when exercising a number of key functions under various Acts related to highways. These have been summarised in Tables 2.1 and 2.2 in Chapter 2.
- 9.1.4 Unfortunately in the past, some highway authorities have not always carried out these functions in a way that would be compatible with the aims of the new Act. Some newly-built highways and “improvement” schemes have failed to improve conditions for pedestrians and cyclists – and in some cases have made things worse.
- 9.1.5 General highway schemes provide excellent opportunities for the creation and improvement of active travel routes. Authorities should therefore in future place as much importance on walking and cycling as on other types of traffic when creating, improving, maintaining and managing highways. It should be noted that the duties of authorities under Traffic Management Act 2004 to maintain the free flow of ‘traffic’ includes both cycle and pedestrian traffic.

## 9.2. Process - General

9.2.1 Manual for Streets (2007) set out a generic process for all highway schemes, as shown in Figure 9.1 below:

9.2.2 Further details on this process is given in Chapter 3 of Manual for Streets, but In terms of providing for active travel, the key steps are:

- objective setting
- design
- auditing

**Figure 9.1 - Generic Process for Highway Schemes**



C





### Objective Setting

- 9.2.3 Whilst many schemes to build new or improved highways will have a prime objective – for example to reduce congestion or to provide access to a new area of development – it is important that authorities give careful consideration to all of the possible objectives of a scheme before beginning the planning and design process.
- 9.2.4 With the Active Travel Act now in force, authorities should always expressly include the objective of enhancing provision for walking and cycling; and translate this into specific and measurable outcomes; for example making a suitable link from this residential area to that school. This will enable the emerging design options to be assessed against these stated objectives.
- 9.2.5 Similar objectives should be set when external agencies, such as developers or other public sector bodies – for example health and education authorities – are responsible for delivering new highways as part of new developments. This will require close collaboration between highway and planning authorities.

### Design

- 9.2.6 Designs of new and improved highways will need to strike an appropriate balance in order to best meet the various objectives that have been set. Further details on the design of networks and elements to meet the needs of active travel are given in Chapters 5 and 6.
- 9.2.7 There may sometimes be a tension between objectives, for example between increasing motor traffic capacity and providing for pedestrians and cyclists, but the statutory obligation to enhance provision for active travel means that this should be given a high priority throughout the design process.

### Auditing

- 9.2.8 Whilst it is common for highway schemes of all types to be subject to a Road Safety Audit, authorities should give consideration to more broadly-based audit techniques. These should be used to check how well a design meets the objectives that were set for it at the outset.
- 9.2.9 Where a Road Safety Audit identifies that a scheme departs from safety related design standard, all options to mitigate for the issues raised should be explored. The actual level of risk posed by issues highlighted should also be considered and a risk assessment of these may be useful in considering an appropriate proportionate response; it is important that

the usefulness of an active travel route is not compromised by an over-cautious approach to road safety – for example by installing unnecessary guardrail which reduces directness and attractiveness. It is important to remember that designs do not ‘pass’ or ‘fail’ a road safety audit; see Manual for Streets 2 for further guidance.

- 9.2.10 Given that objectives should in future include enhancing active travel, the audit process should normally include assessments of the quality of provision for walking and cycling. This could be by undertaking a Non-Motorised User Audit to HD 42/05 of the Design Manual of Roads and Bridges, although this is fairly general in nature.
- 9.2.11 A more detailed tool for assessing walking routes is included in Appendix B, and a tool for assessing cycling routes is included in Appendix C.
- 9.2.12 In situations where there are many competing types of objective (for example in sensitive locations in historic centres), a Quality Audit (QA) may be helpful. Further details of the QA process is given in Traffic Advisory Leaflet 5/11. Cardiff Council uses a Combined User Audit, which is a simplified version of the QA and which considers other aspects of a scheme than simply road safety.

### 9.3. Creating New Highways

- 9.3.1 New roads and streets are created either by authorities themselves using powers under Part 3 of the Highways Act 1980, or by the private sector by an Agreement under Section 38 of the same Act.

#### Public authority-promoted schemes

- 9.3.2 When public authorities are promoting new highways, it is important that active travel modes are properly planned and designed for from the outset, rather than being seen as an ‘add-on’ once the needs of motor traffic have been considered. Designers of new highways should consider the five attributes of good walking and cycling routes given in earlier chapters - Coherent, Direct, Safe, Comfortable and Attractive – and find ways to meet them as part of the scheme.
- 9.3.3 This means that whenever a new link is first being planned, its place within the existing and future network of walking and cycling routes is considered. In rural areas there may be only low numbers of journeys by foot and cycle, but nevertheless the designers of rural road schemes should always identify where walking and cycling routes could be severed



by the scheme, and appropriate mitigation measures included so that pedestrians and cyclists also benefit, or as a minimum are left no worse off.

- 9.3.4 New highways in urban areas will almost always affect large numbers of actual and potential active travel journeys and so designers take great care to identify how the scheme can make them better.
- 9.3.5 For example, a town bypass scheme or urban relief road will usually intercept a number of major and minor roads leading to the town centre. New and enlarged junctions on these roads can present real difficulties for pedestrians and cyclists travelling into the town from the surrounding areas if they are not well designed. In future, Authorities should make enhanced provision for people on foot and cycle at all junctions along a scheme, so that the use of these modes of travel is encouraged.
- 9.3.6 The route of a new highway itself provides a major opportunity for enhancing provision for active travel, simply on the basis that it provides the opportunities for journeys that are not presently being made. As a general rule, all highways, even in rural areas, should provide paved footways and cycle facilities that are appropriate to the volume and speed of motor traffic that will be using it and the number of users that can be anticipated.
- 9.3.7 The appropriate design solution for the junctions and links making up a new highway should be determined from the advice given earlier. Chapter 5 advises on the assessment of the importance of the active travel routes that are intercepted by a new highway, or are formed along the new route itself. This will enable designers to establish the importance of the route in the overall network and help to establish the likely level and type of demand. Chapter 6 then provides detailed advice on how to design network elements that meet active travel needs, and these should be incorporated into the overall design of the scheme as appropriate.
- 9.3.8 Planning and designing for active travel at the earliest opportunity is particularly important when land is to be acquired to enable a new highway to be built. Establishing sufficient land to include footways and cycle facilities of suitable width and type, together with any verges and planted strips, is vital. If compulsory purchase is required, it will be necessary to justify the amount of land that is needed, and reference may need to be made to the standards and guidelines given in this document as part of the case for acquiring land.



### Highways resulting from new development

- 9.3.9 Many new highways are promoted, funded, designed and built by the private sector (and by other bodies such as health and education authorities) as part of new development schemes. Even though the local authority may not be directly responsible for the scheme, it must use its powers to control development and approve technical designs to fulfil its obligations under the Active Travel Act to bring benefits to pedestrians and cyclists.

#### Photo 9.1 – Cycle track provided with new road scheme, Swansea



- 9.3.10 In some cases new developments can provide entirely new routes away from the site itself – for example a large housing scheme may fund a bypass or other type of new link under an agreement to S106 of the Town and Country Planning Act 1990. In this case the guidance given in the preceding section will again apply – an entirely new link is being created which will intersect existing walking and cycling routes and will itself provide a new opportunity for active travel.

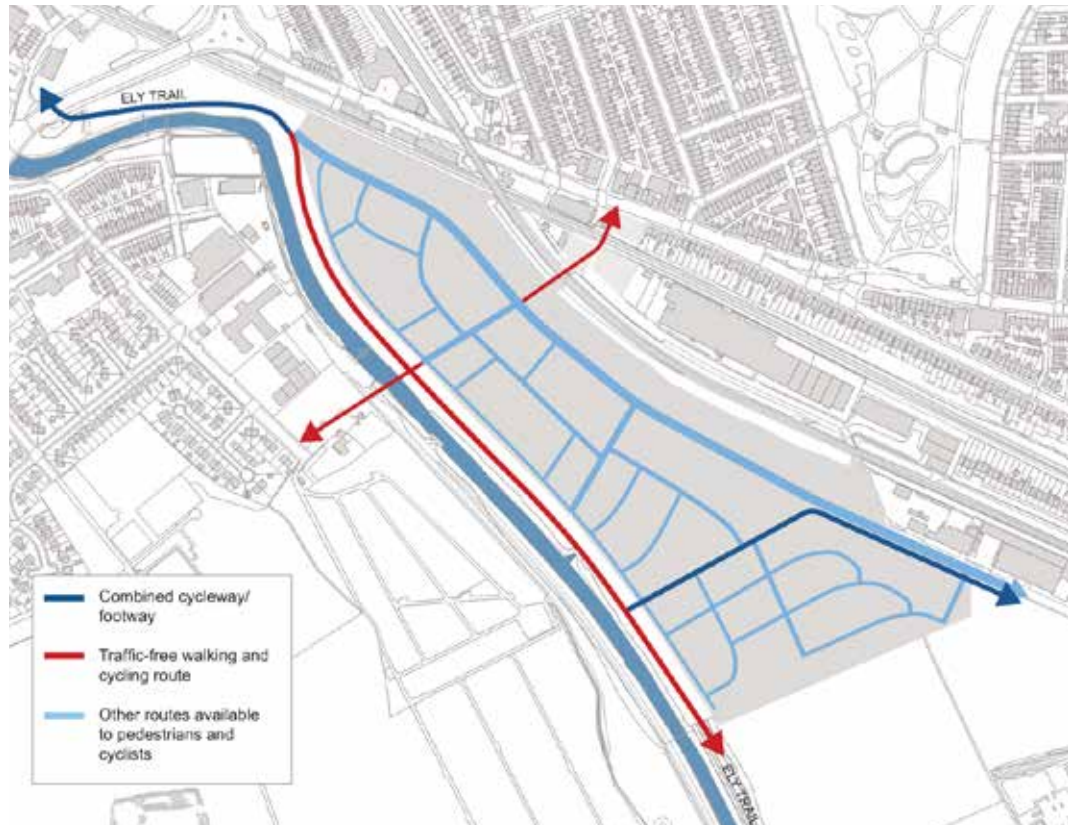
- 9.3.11 In most cases, however, the new highways will be built as part of the development itself, and will be offered for adoption under Section 38 of the Highways Act.
- 9.3.12 Most new highways of the second type are designed in accordance with local authority design guides. These normally lay out minimum geometric parameters for roads and streets serving residential and commercial developments and should generally be in conformity with the advice contained in Manual for Streets 1 and 2, which place greater emphasis on the needs of pedestrians and cyclists.
- 9.3.13 The passing of the Active Travel Act and the publication of this guidance means that authorities should again review their design guidelines to ensure that proper provision is made for active travel by developers' design teams. This will require a consideration of the basic elements making up new highways – motor traffic lane widths, cycle lanes/ tracks, footways, verges and so on – to ensure that highways on new developments provide appropriate facilities for walking and cycling as a matter of course.
- 9.3.14 In new developments, the planning and design of new and improved infrastructure will be led by the Transport Assessment, which is used to provide forecast of the all-mode travel demands of new developments, assess their impact on the surrounding network and design appropriate mitigation measures. It should be noted that smaller developments, on designated active travel routes, which fall below the normal thresholds to provide Transport Assessments should still be required to contribute to active travel improvements.
- 9.3.15 In general, it is important not to err on the side of high motor traffic forecasts on the assumption that it is always best to use 'worst case' figures for trip generation. Using high motor traffic flows will tend to lead to the over-design of links and junctions, which may make it more difficult to provide good facilities for pedestrians and cyclists. The requirements of the Active Travel Act mean that the designers should take reasonable steps to enhance the provision for walkers and cyclists when considering highway works.



- 9.3.16 Active travel routes and networks should be a fundamental consideration when the layout of new developments is being planned and designed, and again the processes set out in Chapters 5 and 6 should be followed. Larger developments will have important destinations within them – schools and retail centres for example – and suitable links to them from new and existing residential areas should be planned.
- 9.3.17 Although some new active travel routes may be along motor traffic-free links, for example through parks and open spaces, it is likely that they will mostly be along streets that are also used by motor vehicles. Designers should therefore carefully assess the speed and volume of motor traffic that can be expected along new internal links. If necessary these will need to be limited through traffic calming and traffic management techniques, as set out in Chapter 6, to ensure that cyclists (and in some cases pedestrians) are able to share the carriageway with motor vehicles.
- 9.3.18 Where speeds and volumes are higher, separate cycle lanes/tracks (and in most cases footways) will be needed. Guidance on the appropriate thresholds for cycling is contained in Table 6.2 in Chapter 6.
- 9.3.19 In almost all cases there will also be the need for connections to places beyond the development itself – for example to a nearby town centre or major employment zone – and it will be necessary for good connections to be made by foot and cycle to these places from all parts of the site.
- 9.3.20 Active Travel connections should not be seen as optional; they are as important as points of general access and off-site improvements to cater for motor traffic increases, and developments that do not adequately make provision for walking and cycling should not be approved. In many cases this will mean that off-site improvements along existing highways that are specifically for active travel – for example the introduction of cycle lanes or tracks, or reductions in speed so that sharing the carriageway is made acceptable – will be necessary in order for the development to be made acceptable.



**Figure 9.1 – Planning for walking and cycling at the Masterplanning Stage. The Mill, Cardiff**



## 9.4. Improving Highways

9.4.1 In the past, some highway ‘improvement’ schemes have tended to focus on increasing capacity for motor traffic, which have sometimes made the situation worse for pedestrians and cyclists, by widening carriageways and enlarging junctions. The duty to enhance provision for walking and cycling placed on authorities by the Active Travel Act means that this is no longer acceptable.

9.4.2 Improvement schemes that are specifically designed to make conditions better for walking and cycling have also taken place and will continue, such as the provision of new zebra or signal-controlled crossings. Where cycling schemes have been carried out they have tended to be of a standard below that which is now required – for example the conversion of footways to shared use facilities.



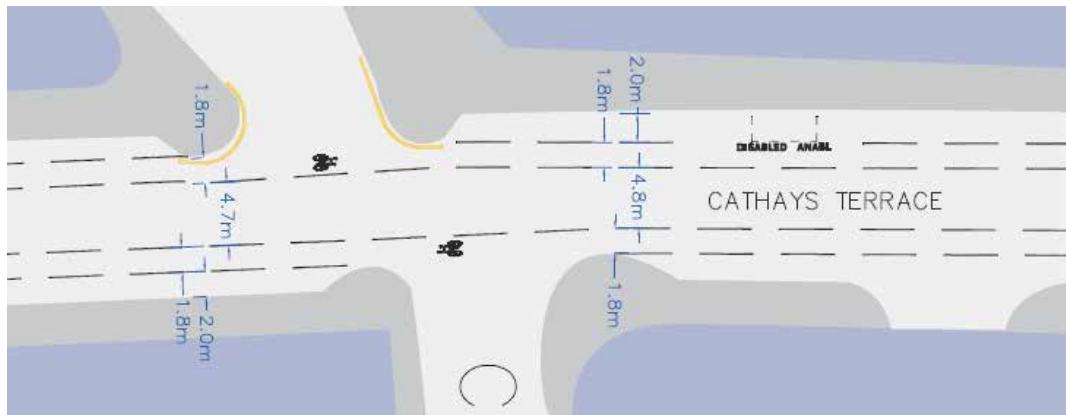


- 9.4.3 With the passing of the Active Travel Act it is expected that authorities will increasingly be promoting schemes that specifically improve conditions for walking and cycling, particularly along designated Active Travel Routes, but also on all other all-purpose roads where cycling and walking are permitted.
- 9.4.4 As noted in Section 9.2 above, even where improvement schemes are mainly justified by a requirement to relieve congestion, their objectives should also expressly include making conditions better for pedestrians and cyclists.
- 9.4.5 There can sometimes be tension between the need to provide additional capacity for motor traffic and creating better conditions for walking and cycling. In considering options, it should be recognised that providing better active travel facilities will encourage more people to use these modes; which in turn will reduce the need to travel by motor vehicle.
- 9.4.6 In general the planning and design considerations for improved highways are similar to those for new schemes – the importance of the active travel links through the scheme should be considered in accordance with chapter 5 and the advice contained in chapter 6 should be followed when the scheme is designed.
- 9.4.7 Where improved highways require additional land to be acquired, again care should be taken to ensure that the area is of sufficient size to enable proper provision to be made for pedestrians and cyclists.

#### **Improvements through maintenance**

- 9.4.8 Highway maintenance issues are covered in general in Chapter 10, but it is important to note here that improvements for active travel – particularly cycling - can be achieved at minimal cost during maintenance operations.
- 9.4.9 During resurfacing, road markings are often removed, and this creates an ideal opportunity to reallocate the amount of carriageway given to motor traffic and cyclists. General traffic lanes can be narrowed, wide central hatching can be removed and the resulting space given over to cycle lanes, which can also be protected with light segregation, all at minimal or low cost.

**Photo 9.1 a/b/c – Cycle lanes were widened to 1.8m on Cathays Terrace, Cardiff, during resurfacing**



- 9.4.10 An even lower cost technique, mainly suitable for routes with lower motor traffic volumes and speeds, is to simply not replace centre line markings which has been shown to reduce speeds (see Manual for Streets para 9.3.3). As discussed in Chapter 6, removing centrelines can also enable the provision of advisory cycle lanes with a single all-purpose lane for motor traffic – see DE017.
- 9.4.11 Resurfacing provides an opportunity to improve the riding quality of carriageways. As noted in Chapter 10, Stone Mastic Asphalt provides a much smoother surface than Hot Rolled Asphalt, and is a better surface for cycling.



9.4.12 During maintenance, authorities need to carefully consider which signs are actually necessary – for example ‘End of Route’ signs should be removed and replaced with signing indicating how the route will continue. All redundant or unnecessary repeater signing should be removed. Any signing which reduces the available width or poses a hazard should be relocated as part of ongoing de-cluttering programmes.

## 9.5. Managing Highways

9.5.1 Authorities have a wide range of powers at their disposal and under the Active Travel Act they must now have regard to the needs of walkers and cyclists when using the powers listed in Table 2.2 in Chapter 2. Chapter 4 of these guidelines provide information on user needs.

9.5.2 Under the Road Traffic Regulation Act 1984, authorities are empowered to make Traffic Regulation Orders to regulate the speed, movement and parking of vehicles and to regulate pedestrian movement. Authorities also have powers to make Orders, similar to Traffic Regulation Orders, which require the same or similar procedure to be followed for management of parking and loading.

9.5.3 Examples of TROs which may be relevant to schemes intended to create good conditions for walking and cycling are:

- prohibitions of specific classes of vehicle – by weight, width, length or specific description e.g. goods vehicles above 7.5 tonnes
- prohibition with exemption for certain classes of vehicle – commonly used for providing priority or improving access for cycle traffic and buses
- all motor vehicles prohibited – allows pedal cycles (and horse-drawn vehicles) to continue to use the road, and is normally used to create pedestrianised areas where cycling is permitted.
- prevention of footway (pavement) parking

9.5.4 A TRO may also be made to prohibit vehicles entirely, which would make cycling along a road illegal. Unless there are particular local circumstances, however, authorities should normally allow cycling in pedestrianised areas. The issue of allowing cycling in vehicle restricted areas is discussed in detail in Chapter 6.

- 9.5.5 At junctions, TROs may be used to restrict vehicle movements. These may be shown either by regulatory signs – which prevent certain manoeuvres being undertaken and are indicated by a sign within a red roundel – or by positive signs which make certain manoeuvres mandatory and are indicated by a round sign with a blue background.
- 9.5.6 Authorities should always start with the presumption that cycle traffic should be exempt from these restrictions. Banning movements for cycling will mean that cyclists are required to travel further and exert more energy in order to complete their journeys, and this is contrary to the principles of the Active Travel Act.
- 9.5.7 As noted in Chapter 6, a TRO is currently needed to establish mandatory cycle lanes and although this involves additional time and expense, mandatory lanes do give greater protection to cyclists than advisory lanes. Mandatory lanes can be part time only, but this is not the preferred approach – mandatory lanes should be made full time unless there are exceptional circumstances, so that all types and times of cycle journey are facilitated.
- 9.5.8 TROs or Parking Orders may be introduced to prohibit waiting and/or loading of vehicles at any time or to restrict loading and waiting to certain times and duration. This is normally shown by yellow line markings on the carriageway and the kerb, although these markings can be omitted within Restricted Parking Zones.
- 9.5.9 Authorities should always seek to use Orders to prevent parking and loading in all cycle lanes (both mandatory and advisory) at all times. A cycle lane which is blocked by a vehicle is of no value and will simply place the cyclist in danger when moving out into the traffic stream. Chapter 6 gives details of how car parking and loading can be achieved while still providing safe space for cycling.
- 9.5.10 TROs are also used to set local speed limits and guidance on this is contained in Circular 24/2009 ‘Setting Local Speed Limits in Wales’. Amongst other factors, this guidance states that the needs of vulnerable road users must be fully taken into account in order to further encourage their mobility and improve their safety. Setting appropriate speed limits has significant benefits for pedestrians and cyclists, and the use of 20mph limits is encouraged and supported by the Welsh Government for certain road types, particularly in residential areas. The contribution that 20mph limits and zones make to achieving Active Travel Routes is discussed in Chapter 4.



9.5.11 Where there is uncertainty as to the effects or public response to any traffic management proposals, an Experimental Order under chapters 9-13 of the Road Traffic Regulation Act 1984 may be used, or in any other circumstances where a trial measure is considered appropriate. Trial measures can be particularly useful where there is concern over the effects of reallocating road space on motor traffic capacity – see Leicester example below.

**Photo 9.3 – Contraflow cycle track, Newarke Street, Leicester**



Image courtesy of Kiran Parmar

# 10 Construction, Maintenance and Management

This chapter deals with the construction, maintenance and management of any pedestrian or cycle facility, and associated matters.

It should be noted that for all trunk roads pavements should be constructed as per the requirements of the Design Manual for Roads and Bridges.

## 10.1. Introduction

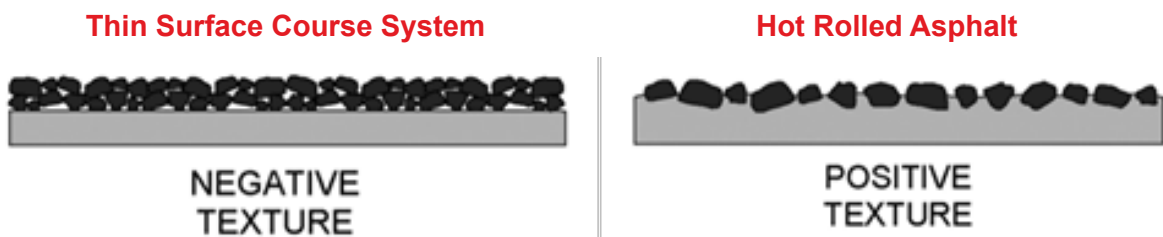
- 10.1.1 It is essential that close attention be paid to construction and maintenance standards and details to ensure that routes used by pedestrians and cyclists are comfortable for all users, including people with mobility, sensory or cognitive impairments, as well as being legal, aesthetically acceptable, easy to maintain and durable.
- 10.1.2 It is important to consider the full life costs and benefits of a scheme. Certain options may require increased capital expenditure at the outset but may result in lower maintenance and management costs. It is only by considering street planning, street design and street management as a whole that pedestrian user needs can best be met. For example, construction costs for a sealed surface path may outweigh those of an unsealed path, but this is false economy once maintenance requirements are included.

## 10.2. On-carriageway cycle routes

- 10.2.1 The typical choice for carriageways is a bituminous surface. Different products are available, each with their own properties, but the main choice is usually between Hot Rolled Asphalt (HRA) and Thin Surface Course System (TSCS).



10.2.2 All routes for cyclists should be machine-laid rather than hand-laid, which is less regular. As noted in Chapter 4, a smooth surface with negative texture significantly reduces the effort needed to cycle, adding to comfort. For this reason, TSCS is recommended as the preferred surfacing for Active Travel Routes.



10.2.3 Modifications to the surface may be required to incorporate cycle lanes, advanced stop lines, or traffic speed control measures (traffic calming). Dimensional tolerances should follow normal highway standards.

10.2.4 Where kerb re-alignment is needed any new carriageway construction should be to normal highway standards unless there is kerb segregation of the cycle lane, when a lighter construction should be used, although surface quality should still be to highway standards.

### 10.3. Coloured surfacing

10.3.1 In most situations, as noted in Chapter 6, black bituminous surfacing in conjunction with cycle logos and appropriate lane markings is satisfactory in most circumstances and colour should be used sparingly. Extensive use of coloured surfacing is not recommended for maintenance reasons, and poorly maintained coloured surfacing can pose an additional hazard for cyclists.

### 10.4. Footway construction

10.4.1 Footway construction should be of sufficient depth to withstand the loads likely to be imposed on it.

10.4.2 Consideration should be given to the likelihood of accidental or intentional overrun of a footway by heavy vehicles and the thickness increased accordingly. The construction at vehicle crossovers will need to be thicker than the adjacent lengths of footway. Cracking or rutting of surfaces due to overloading can be unsightly, create trip hazards and/or drainage problems. The construction specification for footways, footpaths and cycle tracks is contained in HD39, Tables 3.1 to 3.4.

## 10.5. Footpath construction

- 10.5.1 Where a footpath is constructed away from the highway consideration should be given at the design stage to the practicalities of constructing the path and in particular access arrangements for construction vehicles. Access points to some paths can be several hundred metres away and may require material to be moved by dumper truck. This might be satisfactory for moving sub base materials, but keeping tarmac hot enough to lay properly may be a concern. Additional access points may need to be constructed, and the path may need to be able to carry plant associated with the works.
- 10.5.2 Where a footpath also serve as access routes for maintenance vehicles e.g. adjacent to waterways, the surfacing and construction of the path needs to reflect this.
- 10.5.3 It may also be appropriate to thicken sub base layers, or use geotextile materials if necessary where ground conditions are poor. Where paths use land that is contaminated avoid excavating in these circumstances and lift path levels if areas are unavoidable.

## 10.6. Cycle Track Construction

- 10.6.1 It should be borne in mind that one of the most common reasons why some cyclists use the main carriageway in preference to a cycle track alongside the road is that the riding quality of the main road carriageway is better. The riding quality of the cycle track should be at least as good as that of the adjacent road and should be machine laid.
- 10.6.2 Among the most important considerations in choosing an appropriate surface material are cost (and variation by colour), durability and skid resistance. Polished stone value (PSV) gives a measure of skid resistance. A PSV of 55 is normally acceptable for road skid resistance. Table 10.1 below shows, indicatively, a comparison of different surface materials and treatments according to these criteria.

**Table 10.1 Surface treatments for cycle routes**





Surface Material <sup>1</sup>	Life (years)	Skid resistance (PSV)
6mm asphalt concrete	20	60+
Coloured TSCS, 30-50mm thick	20	55+
Block paving	20	55
Brick paving	20	-
Concrete paving flags	10	-
Tactile paving	10	-
York stone flags	20	-
Granite paving flags	20	-
Thermoplastic High-Friction Surfacing	4-6	70+
Resin High-Friction Surfacing	8-10	70+
Cycle Track Veneer (thermoplastic slurry)	5	55+
Cycle Lane Veneer (polymer binder)	10	55+
Slurry Seal (poor colour and life)	5	55
Surface Dressing – Granite Stone (bituminous binder)	20	60+
Surface Dressing – Granite Stone (clear binder colour enhance)	20	60+
Surface Dressing – Pea Shingle Stone	20	50

- 10.6.3 The preferred surfacing is machine laid bituminous material, although bound or unbound aggregate, concrete or stone flags or paving blocks are sometimes used. Unbound aggregate surfaces are generally unsuitable in an urban / urban fringe environment as they cause excessive dust in dry weather and can be susceptible to ponding and become muddy and in wet weather, leading to rapid deterioration; for these reasons they are not generally recommended.
- 10.6.4 Generally paving blocks and concrete or stone flags will provide a more aesthetically attractive finish and are more suited to high quality public realm areas, but will be less comfortable to cycle on and can be more problematic to maintain.
- 10.6.5 There may be local sensitivities around surfacing of paths with black bituminous material in areas of high heritage value or green spaces and these should be considered and addressed as part of the consultation. If necessary, paths can be surface dressed with appropriate materials.

## 10.7. Tactile paving

- 10.7.1 Tactile paving is provided on walking routes to assist visually impaired people in moving around an area and on segregated shared-use routes to enable them to navigate safely, preventing them from walking into the cycle track inadvertently. Types of tactile paving used and their typical uses are listed below in Table 10.2. The most common form of tactile paving provided in association with walking routes is blister type tactile paving at road crossings.

**Table 10.2 – Common Tactile Paving Types for Pedestrian and Cycle Areas**

Type of tactile paving	Typical usage	Typical example
Blister (red coloured)	Signalised pedestrian crossing facilities, including zebra and toucan crossings	
Blister (buff coloured)	Uncontrolled pedestrian crossing facilities	
Corduroy	Where a footway joins a shared use path, top and bottom of steps or other hazard	
Ladder/tramline	Start, end and repeater indication of segregated footway/ cycleway (ladder on footway side and tramline on cycleway side)	

C




- 10.7.2 Guidance on the provision of tactile paving is set out in the Department of Transport publication 'Guidance on the Use of Tactile Paving Surfaces' and reference should be made to that document when specifying tactile paving.
- 10.7.3 Current national guidance covers simple layouts but does not give detail for the wide variety of layouts that are encountered in reality. For non-standard layouts engineers need to apply the principles contained in the guidance and consult with local groups representing the visually impaired during the design process.

## 10.8. Kerbs, edgings and verges

- 10.8.1 Footways may require some form of edge restraint in order to maintain their structural integrity. Where a footway is not adjacent to a wall or building this can be provided by an edging strip. Edgings are generally formed from precast concrete units. Any edge treatment will increase the overall cost - pre-cast concrete kerbing roughly doubles the cost of a path.
- 10.8.2 Where a footway is provided adjacent to a road the footway will normally be delineated from the adjacent carriageway with a kerb. This offers a degree of protection to pedestrians and can assist blind or partially-sighted pedestrians identify the edge of the footway.
- 10.8.3 In low vehicle speed environments where a 'shared space' is being created it may be appropriate to omit the kerb. In these cases the impact of not providing a kerb on blind or partially-sighted users should be considered with appropriate use of tactile paving, or a low kerb upstand be retained. Further guidance on the design of shared space areas is given in Chapter 6.

10.8.4 Kerb heights should be as set out in Table 10.3:

**Table 10.3 – Kerb Heights**

Location	Upstand	Typical example
General	75mm to 125mm Half battered profile adjacent to footway Splayed (45°) where no adjacent footway and on high speed roads	
Pedestrian or cyclist crossing	Flush with tactile paving Any upstand makes it more difficult for wheelchair users	
Vehicle crossover	25mm To maintain continuity of edge of carriageway drainage and provide a continuation of the kerb line for blind or partially-sighted pedestrians.	

10.8.5 Away from the carriageway edgings are generally formed from precast concrete units but in rural or more lightly used situations timber edges can be used. However, in many locations away from the highway an alternative to kerb edgings is to construct the sub-base and binder course 300mm wider than the path, providing a 150mm shoulder on either side to support the path.





- 10.8.6 Where a footway or cycle track is provided adjacent to a higher speed, or more heavily trafficked road the footway should be separated from the adjacent carriageway by a verge, typically at least 1m in width, in order to provide a margin between the active travel path and vehicular traffic. In most cases this margin is likely to be grassed.
- 10.8.7 On off-carriageway routes, a verge of between 0.5m and 1m should be maintained each side of the path, as mown edges prevent the vegetation encroaching and making a footpath or cycle track unusable, or reducing the extent of usable width. The remainder of the verge may be left and can be of value to wildlife.

## 10.9. Drainage

- 10.9.1 Standing water and poorly-designed surface water run-off can cause problems for pedestrians and cyclists users and seriously damage pavement construction. Keeping water off and moving it away from a carriageway or path will increase the longevity of the pavement structure and increase its use. Any drainage system needs to be efficient and reliable and may need to extend beyond the immediate edges of a new path to be effective.
- 10.9.2 Where water comes from and how it is disposed of needs proper consideration. It is important to include proper drainage within a design. Poor drainage can give an impression of a forgotten route and lead to safety and maintenance problems.

### On carriageway drainage

- 10.9.3 When cyclists are on carriageways, attention will need to be paid to gully location and levels, which are critical for cyclists as well as ensuring good route drainage. This is particularly important where full or light segregation for cycling has been introduced, since cyclists will find it difficult to avoid gullies. Acceptable gully characteristics are as follows:
- in any location where there is a possibility that cycle wheels will cross gullies, the grate slots should be at right angles to the direction of travel. Alternatively, non-slot 'pedestrian style' gratings should be provided.
  - no gaps between the frame and cover wider than 15 mm
  - recessed gully frames raised to be flush (tolerance +/- 5mm) with the surface
  - suitable for their location to take public highway loadings
  - open in a manner suitable to be cleansed by a normal gulley cleansing or jetting machine under the relevant highway authority contract

- 10.9.4 Dished and other gratings unsuitable for cycling across should be replaced. Side-entry gullies or perforated kerb type gullies may be suitable in some circumstances, particularly where there is restricted width and where cyclists will be close to the kerb.
- 10.9.5 Fully segregated cycle tracks and hybrid tracks will need additional gullies as well as appropriate falls to facilitate run-off. A minimum grating size of 300 x 300mm is recommended, as the smaller size gully gratings that are sometimes used in off-carriageway situations tend to block.
- 10.9.6 A gully should be provided in the carriageway at the upper side of any pedestrian / cycle crossing in order to prevent surface water running across the point at which people step into the carriageway.

**Off-Carriageway Routes**

- 10.9.7 Where new routes are being provided, or widened into soft verges consideration should be given to the effects of any increase in the volume of surface water run-off contributing to the existing drainage system. Once taken off the path surface it is essential that water is returned back into the system at a suitable location. This requires careful thought and understanding. Simply diverting over land run off, or removal of flood water into the nearest ditch or culvert may create problems further downstream.
- 10.9.8 To prevent ponding of surface water, or the formation of ice, a crossfall or camber should be provided on the carriageway or path surface within the limits stated in Table 10.4 below. Excessive crossfall is uncomfortable to walk on and can cause difficulties for wheelchairs, pushchairs and cyclists.

**Table 10.4 – Crossfalls**



	<b>Crossfall (%)</b>
Minimum	1.5
Preferred	2.5
Desirable Maximum	3.3
Absolute Maximum (at crossings)	10






- 10.9.9 The direction of the crossfall should be set so that surface water does not run-off onto adjacent property where there is no highway drainage along the boundary. Typically footways will fall towards the adjacent carriageway. On cycle tracks the crossfall should generally fall towards the inside of a bend.
- 10.9.10 Where it is not possible to provide a continuous crossfall across a path, either due to the relative levels between the kerb and the back of the path or the width of the path, it will be necessary to provide drainage channels within the path. Table 10.5 sets out four options.

**Table 10.5 – Drainage Channels on Paths**

Measure	Advantages	Disadvantages	Typical example
Dished channel blocks	Easy to maintain	Trip hazard Requires gullies Can result in ponding water Not suitable on cycle routes	
Flat channel blocks	No trip hazard Easy to maintain	Less capacity Requires gullies Can result in ponding water	
Linear channel with gratings	Can avoid having to create a low spot in a surface	Prone to blocking and silting up Gratings can work loose and cause trip hazards	



<p>Linear slot drain</p>	<p>Visually un-intrusive</p> <p>Can have high capacity (in pipe below ground)</p>	<p>Prone to blocking and silting up</p> <p>Have to be jetted or rodded to be cleaned</p>	
--------------------------	---	--	--

10.9.11 If gullies or gratings are used as part of a path drainage system a heel proof grating should be specified.

## 10.10. Access Controls

10.10.1 Access Controls are sometimes placed on off-carriageway routes to prevent access being gained by unauthorised vehicles, particularly motorcycles.

10.10.2 It is recommended that designers should start with a presumption against the use of any form of access control, as these cause difficulties to many legitimate users and are often ineffective in addressing the issues they are intended to address. In particular, restrictive access controls:

- are inconvenient, can be unsightly and can actively discriminate against some user groups who have legitimate rights to use a path.
- extend the journey time for cyclists and so reduce the utility of a cycle route
- add another level of cost, and maintenance concern, to a path.
- are frequently ineffective because fencing along a traffic free corridor is missing, broken or subsequently vandalised so that the access control can be bypassed.

10.10.3 There is also a tendency to install access barriers to stop, or slow, cyclists at the end of a path for safety reasons – whether actual, or perceived. This is often inappropriate, and designers fail to consider other solutions, such as clear signing and (if necessary) other means of slowing cyclists such as changing path geometry.

- 10.10.4 A single bollard, and clear sight lines will be effective in many locations. Double rows of bollards, with a minimum spacing of 1.50m can reduce cycle speeds and prevent motor vehicle access, whilst retaining better permeability for users than chicane barriers.

**Photo 10.1 – Access Control using bollards, Weymouth**



- 10.10.5 Sustrans' document "A guide to controlling access on paths" provides detailed information on assessing whether an access control is needed, and if so the most appropriate design solutions. It covers:

- legal issues, including the Equalities Act
- whether an access control is required
- alternative measures to control access
- risk assessment
- deciding on type of access control required
- design parameters
- layout and design solutions



## 10.11. Fencing and Hedgerows

- 10.11.1 Fencing may be required along off-highway paths for the safety of users, the security of neighbours and livestock control. Where needed fencing should remain visually unobtrusive.
- 10.11.2 The installation of fencing has an impact upon all route users, but greater impact upon cyclists as a fence immediately adjacent to the path edge reduces the effective path width by 500mm.
- 10.11.3 Fencelines set 1m away from a path edge will generate a better visual aspect, and where required on both sides of a path reduce the “tunnel effect”. Verges will allow space for drainage, and if necessary ducting for lighting.
- 10.11.4 Security fencing can be harsh and oppressive, creating environments that are visually off putting to pedestrians and cyclists alike.
- 10.11.5 Under most circumstances 1.5m high fencing is, or should be, adequate in all but exceptional circumstances. To a pedestrian they still provide views over, and the visual and aesthetic impact upon a traffic free route is considerably less.
- 10.11.6 Hedgerows form part of the immediate environment for many paths away from or alongside the road. Developing routes that include at least one hedgerow as a boundary feature can re-invigorate them as dead wood, brambles and unwanted species are removed and new growth encouraged. Thorny species such as Hawthorn or Dog Rose should be avoided where necessary, but if used will require planting further back from the path edge to prevent hedge clippings causing punctures.
- 10.11.7 Sustrans Technical Information Notes E 01 “Hedgerow Management” provides further guidance on hedgerows alongside cycle routes.

## 10.12. Lighting

- 10.12.1 If walking and cycling are to play an important role as an alternative to the car for short journeys they must be promoted as around-the-clock means of transport, rather than just a daylight activity.
- 10.12.2 Many walking and cycle journeys will be made after dark, especially during the winter months, and routes should normally be lit to provide an adequate level of safety, both real and perceived. It is recognised that



some authorities are looking to reduce lighting to reduce costs and light pollution, but the benefits of lighting a walking or cycling route include enabling users to:

- orientate themselves and navigate the route ahead
- identify other users ahead
- detect potential hazards
- discourage crime and increase a sense of personal security

10.12.3 It is important that the provision of lighting is considered at an early stage in the design process, so that the issues can be properly considered and the needs of users taken fully into account in the choice of equipment and the design of the scheme.

10.12.4 Routes along urban and many rural highways will be lit by the existing highway lighting but specific lighting will be needed for off-highway routes. However, in lighting such routes consideration also needs to be given to wider factors, including:

- limiting levels of light pollution
- level of ambient brightness in the surrounding area
- the visual impact of the lighting equipment
- intrusion on nearby properties
- the needs of visually impaired users for uniform illumination at surface level
- vandalism issues
- proximity of electricity supply
- energy usage and cost
- costs of installation, operation and maintenance

10.12.5 Sustrans Technical Information Note 12 Lighting of Cycle Paths, 2012 provides further guidance on lighting

## 10.13. Maintenance and Management - Introduction

10.13.1 Maintenance of the path or carriageway surface is of great importance to pedestrians and cyclists, including proper reinstatement following works by statutory undertakers. For routes away from the highway it is essential to establish responsibility for maintenance of the path, and put into place a regular regime for inspections.



10.13.2 A route that is kept in good condition will be more useful, attractive and popular than one allowed to deteriorate. Maintenance needs to be well planned as, having invested time and money by building the route, it is important that it remains attractive to users.

10.13.3 Programmed maintenance of the wider highway network can offer opportunities to enhance the network of walking/cycling routes if properly planned – see Chapter 9.

10.13.4 Walking and riding quality should be maintained, particularly keeping routes clean and ice free in autumn and winter.

## **10.14. Designing with maintenance in mind**

10.14.1 Maintenance should be considered as part of the route development process long before construction starts. A thoughtful design will mean less maintenance in the future. For example an off-highway path surfaced with bituminous material will have a long life needing little maintenance.

10.14.2 The future maintenance burden, both financial and operational, on local highway authorities for any new cycling and walking infrastructure should be a major consideration for designers and it is recommended that both a Value Engineering and Future Maintenance Audit are carried out on all proposed designs before implementation.

10.14.3 It is particularly important to think about maintenance at the start of the design process if the project has capital funding available but maintenance will have to come from existing budgets. Sometimes money can be put aside from the capital source into a separate fund for future maintenance. Irrespective of what the ultimate arrangement will be, it is essential that the design team has agreed the future maintenance arrangements early in the scheme's development.

## **10.15. Maintenance Responsibilities**

10.15.1 As noted in Chapter 2, most active travel routes will almost certainly be highways under the definition of the Act (a highway being a route that the public has the right to pass and re-pass), but this does not mean that the highway authority is responsible for their maintenance. Where the route is on the road it will usually be the responsibility of the highways authority but some routes may well be the responsibility of another part(s) of the council – for example the education authority if the route is through school playing fields.

- 10.15.2 Every department with future responsibility for the maintenance of the route needs to accept those responsibilities at the outset of the project and allow for them in future budgeting.
- 10.15.3 Many local parks and former railway greenways have local volunteer groups supplementing the staff carrying out the bigger maintenance tasks. They provide a hugely valuable role, ensuring the local community is involved in its local path and promoting its use, while carrying out smaller maintenance tasks.

## 10.16. General Maintenance Tasks

- 10.16.1 Each local highway authority will have its own defect intervention criteria as part of the 'well maintained highways' process and established safety inspection regimes based on the hierarchical status and functionality of each asset.
- 10.16.2 The following list, though not exhaustive, gives some indication on the type of defects that affect walking and cycling network safety and serviceability.
- carriageway, footway and cycleway surface defects
    - » broken/uneven riding or walking surface with defects meeting or exceeding applied intervention criteria.
    - » worn riding or walking surface with suspect skid resistance - where appropriate, testing of the surface should be carried out to ensure adequate skid resistance for traffic expected to use it
    - » defective kerbs, edging and channels
    - » consider prioritising the section of the road where people usually cycle i.e. the first 2m or so from the kerb needs to be in good condition.
  - drainage and utility covers maintenance
    - » missing or damaged inspection or drainage covers and frames
    - » surface water flooding or severe standing water
    - » blocked surface water gullies and drainage systems
    - » ironwork surface texture



- ironworks, such as drainage gullies and utility covers, are particularly hazardous for cyclists, being both slippery in wet conditions, and often associated with potholes which form around their edges. Where cycle routes are located on roads shared with traffic, such surface defects can lead to greater conflict, with people on bikes often having to make often risky manoeuvres.
- guardrail, fencing and restraint systems
  - » missing or damaged posts, rails or barrier likely to cause a potential danger or render system ineffective
- signing, road studs and markings
  - » missing, damaged or illegible sign faces.
  - » damaged post or fixings
  - » insufficient headroom from underside of sign
  - » insufficient offset from trafficked areas
  - » post / sign obstruction to passage or visibility
  - » loose sign brackets resulting in turned sign face
  - » missing or damaged road studs
  - » missing , faded, worn or incomplete markings
- streetlighting, traffic systems, pedestrian and cycle crossings
  - » daytime lamp burn
  - » lamp out
  - » damage, corrosion to columns or posts
  - » damaged / turned heads or lanterns
  - » missing/loose access doors to columns or cabinet
  - » missing / damaged tactile paving at crossing
  - » missing / damaged tactile rotating cone on crossing

- verge, trees and hedges – on both rural and urban routes
  - » obstructed visibility or physical obstruction to free passage by vegetation, particularly at junctions and crossing points; cuttings to be kept clear of path surface.
  - » root heave to surrounding walking or cycling surface
  - » obvious damage, disease or poor condition of any tree within falling distance of the route
  - » need for periodic cutting back of adjacent grass verges or banks to maintain full width of asset
  
- cleanliness and weed growth
  - » unacceptable levels of leaf litter likely to cause drainage or safety issues for users
  - » unacceptable levels of litter, detritus or dog fouling
  - » sign face cleansing
  - » unacceptable levels of weed growth
  - » presence of noxious weed growth
  - » programmed cleansing of litter/dog fouling bins

10.16.3 A poorly cleansed surface, apart from discouraging users, can present real dangers to the user. Bypasses and gaps for cyclists do not benefit from the movement of motor traffic to push debris out of the way, so these need to be of sufficient width for street sweepers and be regularly swept if they are to be usable.

10.16.4 Broken glass is one of the more obvious dangers to both cyclists and walkers. Excessive leaf litter or detritus build up can cause potential slip hazards and impact on the efficiency of surface water drainage infrastructure.

10.16.5 Often more of an issue for off road infrastructure, failure to control weed growth can have a detrimental effect of the safety and serviceability of an asset as well as its attractiveness to users.

10.16.6 If litter bins are provided within the design, they should be cleaned regularly.

## 10.17. Maintaining Active Travel Routes Through Roadworks

10.17.1 Section 9 of the Active Travel Act requires that roadworks should provide suitable provision for pedestrians, including disabled people, and cyclists – and preferably without cyclists needing to dismount. Equipment located on the footway should be fenced off and the accessibility of the route maintained for all types of user, with signed diversion routes where necessary.

10.17.2 TROs may be used to place temporary traffic restrictions on roads during construction in order to enable the works to proceed safely, such as making a route one way.

**Photo 10.2 – Temporary contraflow cycle lane during roadworks, London**



10.17.3 UK Department for Transport guidance concerning street works and road works, *Safety at Street Works and Road Works - A Code of Practice*, states that:

“If your work is going to obstruct a footway or part of a footway, you must provide a safe route for pedestrians that should include access to adjacent buildings, properties and public areas where necessary. This route must consider the needs of those with small children, pushchairs

and those with reduced mobility, including visually impaired people and people using wheelchairs or mobility scooters. You should always try to enable pedestrians to remain safely on the footway if at all possible.” (p28 DfT, 2013)

10.17.4 Chapter 8 of the Traffic Signs Manual states that:

“O3.14.6 Where there is cycle provision, such as cycle lanes or tracks, efforts should be made to keep these open or to provide an acceptable alternative during the road works. They should not be blocked by signs, debris, plant etc”

10.17.5 Road works and any unavoidable consequential route changes must be clearly signed and promoted. Where route changes are planned the local authority must raise awareness in the local community and at key facilities or destinations served by the route. This must include using local radio, talking newspapers, and informing disability groups.

## 10.18. Bridges and other structures

10.18.1 Bridges usually have a separate inspection and management system from the rest of the highway and traffic free networks. Bridge owners such as local councils and Network Rail have sophisticated bridge management systems. These tend to focus on the structural condition of the bridge and can pay less attention to the environment of the bridge. Thus graffiti can remain indefinitely unless reported to the council, making the whole environment feel uncared for and potentially threatening for walkers and cyclists. Underpasses provided for pedestrians and cyclists to avoid busy roads are particularly vulnerable to this type of abuse making their use at best an off-putting and sometimes frightening experience.

10.18.2 Smaller bridges in parks and similar traffic-free environments sometimes have wooden decks. Unless these are treated with a good antiskid surfacing material at the time of construction they can become very slippery when wet. Once again, by considering the maintenance problems at the design stage, potential problems can be avoided before they become significant.

10.18.3 It is important to keep trees and bushes cut back close to bridges to allow inspectors a clear view of the structure and to avoid damage. Trees and bushes can cause masonry to crack and painted surfaces to corrode.



## 10.19. Winter Maintenance

- 10.19.1 Local highway authorities are under a duty to ensure, so far as reasonably practicable, that safe passage along a highway is not endangered by snow or ice.
- 10.19.2 Whilst this is not an absolute duty due to the qualification of ‘reasonable practicality’, the Active Travel Act raises the priority of walking and cycling routes and this should be reflected in local authorities’ winter maintenance programmes.
- 10.19.3 It is not reasonable, due to the scale and cost to expect local highway authorities to apply this service to the entire highway network or ensure that treated sections of the network remain ice or snow free. However, well used walking and cycling routes should merit a high priority.
- 10.19.4 It is therefore recommended that local highway authorities:
- undertake risk assessments of which parts of the cycling and walking network should be identified for treatment in Winter Service Plans
  - engage cycling and walking stakeholders and users in the development of policies, winter service and operational Plans
  - advise and inform walking and cycling network users and stakeholders on the extent of the service and safe use during these periods

## 10.20. Highway Enforcement and Custodianship

- 10.20.1 Although not strictly a maintenance function, local highway authorities also have a duty to assert and protect the rights of the public to the use and enjoyment of any highway, including active travel routes.
- 10.20.2 The following list, though not exhaustive, shows typical enforcement or controlling actions that may need to be taken to meet the needs of users and ensure compliance with statutory duties in relation to walking and cycling. All the following have potential to cause unnecessary obstruction or potentially unsafe conditions for both cyclists and walkers, and should be addressed by the local authority or police, as appropriate.
- placing of builders skips within the highway
  - placing of building materials within the highway
  - scaffolding within the highway
  - ‘A’ boards placed within the highway
  - displaying of goods for sale within the highway



- parking on the footway and across dropped kerbs
- parking of trailers or caravans so as to cause obstruction
- illegal signing within the highway
- cutting back of privately owned vegetation encroaching on the highway
- mud and soil deposited on the highway
- control of statutory undertakers and maintenance works



## Key References

Cycling England: Design Guidance, C.06 Maintenance

Sustrans (2012) Trees, Technical Information Note 11

UK Roads Board (2003) Footway and Cycle Route Design, Construction and Maintenance Guide, Application Guide AG26 (Version 2)

Department for Transport (1999) Cyclists at Road Works, TAL 15/99

Sustrans (April 2011) A Guide to Controlling Access on Paths

Sustrans (2012) Technical Information Note 12 Lighting of Cycle Paths

Sustrans Technical Information Notes E 01 "Hedgerow Management" for further guidance

Department for Transport, Guidance on the use of tactile paving surfaces

Transport for London (2013) Cycling Design Standards

UK Roads Board (2005) Well-maintained Highways - Code of Practice for Highway Maintenance Management

Department for Transport (October 2013) Safety at Street Works and Road Works - A Code of Practice

# 11 Monitoring and Evaluation

11.1.1 This chapter sets out the reasons why local authorities should carry out monitoring and evaluation of active travel routes and schemes, and provides advice on how this should be carried out.

## 11.1. Introduction

11.1.1 It is vital that authorities establish a programme of active travel monitoring, which will establish a baseline for measuring future improvement and progress towards targets and policy goals.

11.1.2 As part of the development of individual improvement schemes, monitoring should be considered from the outset and should be built into all projects. The type of monitoring that is undertaken will depend upon a number of factors relevant to the specific scheme itself. This chapter explores some of the reasons for monitoring and evaluation and details how it can be approached.

## 11.2. Why Monitor and Evaluate?

11.2.1 Gathering data around the usage and impact of routes provides the justification for existing plans and schemes, and makes the case for new proposals and helps with exploring future options. Typically monitoring will be used to:

- compare and prioritise scheme design options
- compare active travel schemes with other local transport schemes
- demonstrate that schemes represent value for money
- review operation of experimental scheme that may disadvantage some stakeholders, prior to deciding on whether to make it permanent
- assess the operation of innovative schemes to learn lessons on how the design might be developed / improved in future



11.2.2 When planning a new route or network, or improvements to existing infrastructure, data from other similar routes and networks can be used as the basis for forecasting what usage and impact might look like following the intervention, and for making the case to support the proposition.

11.2.3 The Welsh Government and other funders generally expect to see evidence of the impact of the scheme post implementation. The case for future funding or providing support at public consultation can be enhanced by a quantified (and qualitative) examination of usage.

### 11.3. How to approach data gathering

11.3.1 At the outset a Monitoring and Evaluation Plan should be developed for any intervention and the costs of this should be factored in when evaluating costs. The plan would typically be some variant on a logic map or logic framework – a systematic and visual presentation of the key steps forming a monitoring programme based on the scheme objectives. This requires the identification of

- objectives,
- inputs
- outputs
- outcomes
- impacts

11.3.2 A simple example is given in Table 11.1.

**Table 11.1: Example of a simple Logic Map**

Objective	Input	Output	Outcome	Impact
Improve cycling safety	Infrastructure improvement resources	Physical route, signing	Increased usage, improved perceptions of safety	Reduction in incidence of accidents, congestion reduction



- 11.3.3 In the context of a route or network intervention the parameters can range widely:
- what is the route for? (objectives: increasing commuting, making journeys to school safer);
  - what might the route achieve? (outcomes: increased tourism activity, increased commuting, improved perceptions of safety);
  - what results from the intervention? (impacts: increased tourism revenue, reduced absenteeism, reduction in accidents).
- 11.3.4 The Monitoring and Evaluation Plan, must consider the characteristics of the route or network in question. There are no quick fix ‘counts required per kilometre’ or ‘survey this many users’. Rather the data to be collected should directly address the intended outcomes and impacts, and should relate to what is on the ground. Is there a suitable location for an automatic counter on the route/ network? Are there schools/ workplaces that are served by the route/ network where data can be gathered?
- 11.3.5 Consideration should also be given to unintended consequences, such as the possibility that certain types of users may avoid a route following an intervention. This will not always be easy but good baseline data that identifies the existing level of use by type of user will enable this to be done if it is considered necessary.
- 11.3.6 The other key constraint is cost. The investment in data gathering needs to be proportionate and to address the outcomes and impacts cost effectively. Scaling of costs is not a simple formulaic matter. If a more detailed data set is required, costs are inevitably higher. A low cost scheme may not necessarily correspond to a scheme with a minimal data requirement. Examples in Sustrans’ portfolio include circumstances where 1% of a multi-million pound investment has been spent on monitoring, and where monitoring has amounted to around a quarter of total project cost.

## 11.4. Data gathering tools available

- 11.4.1 Currently very few local authorities collect data on walking unless specific to a particular scheme, and approaches to the collection of data on cycling varies enormously both in approach and robustness. Most monitoring of walking and cycling relate to levels of use.

- 11.4.2 A very wide range of tools for data collection is available. These should be selected according to the information outputs to be generated for the Monitoring and Evaluation Plan. It is absolutely crucial to consider what might already be available from existing national or local datasets that might meet the project’s needs before embarking on tool selection.
- 11.4.3 There is a range of tried-and-tested tools available, which makes any data collection, analysis and comparison to other projects more robust, easy to implement and more cost effective.
- 11.4.4 Table 11.2 lists the most common tools, along with a basic indication of costs, and considers their scale of application.

**Table 11.2: Tools available for monitoring**

Quantitative Tools:	Advantages and Disadvantages
Automatic cycle/ pedestrian counts	Initial investment costs are high due to hardware costs, and there is an ongoing maintenance liability; extent of costs depends on number of counters required, and intensity of coverage required; costs can range from £1,500 to £5,000 per counter unit, depending on specification, but greater for complex locations. Ongoing maintenance costs are also a consideration.
Manual cycle/ pedestrian counts	No hardware costs, but an ongoing cost in commissioning repeat counts; frequency and the number of points to be covered are the primary determinants of cost; expect to pay a standard day rate per count day per site per iteration
Video counts	Modest hardware cost and installation costs, but data is not continuous unless repeat periods of operation are scheduled
Cycle parking counts	Cost depends on area to be covered; expect to pay a standard day rate per person required per iteration



Quantitative Tools:	Advantages and Disadvantages
Beneficiary and participant count record and surveys	Main cost is the time of the project delivery team in administering the tools
Route user intercept surveys	Based on four days coverage per survey event, usually using two people per site; cost is standard day rate times eight for data collection.
Household travel behaviour survey	Usually very expensive for very strong data; survey design and sampling are part of the process, but the bulk of the cost is surveyor time; key cost determinants are level of coverage with respect to sample size and statistical surety; expect to pay £40,000-90,000 per iteration; typical sample size required would be around 1000 households.
Workplace travel surveys	Main cost is the time for administering the survey (may be done in house)
School travel surveys	Main cost is the time for administering the survey; some data may be available through school travel plans where available
Qualitative Tools:	Advantages and Disadvantages
Community impact evaluation <sup>1</sup>	Tools can be supplied at modest cost; main cost is the time of the project delivery team in administering the tools
Process evaluation <sup>2</sup>	Modest costs, requiring a series of interviews with a defined range of stakeholders
Evaluative exploitation of social networking sites, etc.	Modest costs, but needs a clear plan of operation

<sup>1</sup> Surveying participants at events organised by the council or other organisations provides a focused look into the behaviour of individuals who are somehow engaged in active travel initiatives.

<sup>2</sup> Process evaluation involves engaging with stakeholders, partners, volunteers and others involved in project delivery to gauge their impressions of how the programme is being carried out.



'Context' Tools:	
Intervention diary <sup>3</sup>	Tools can be supplied at modest cost; main cost is the time for entering data, which is best done by the project delivery team
Ancillary data	Limited cost for collating existing data; main bulk of costs are for analysis and reporting

## 11.5. Analysing the data

- 11.5.1 The analysis should be planned at the stage of designing the data collection approach and should respond directly to the requirements of the Monitoring and Evaluation Plan. For example, there would be no requirement to report on trips to school if the primary outcome measure is tourism-derived revenue.
- 11.5.2 The complexity of assembling an expression of impact depends on the reporting needs and the data sources used. It is relatively easy to report on the usage of a short stretch of route if counter and user intercept survey data is available.
- 11.5.3 However, this approach can risk significantly underestimating usage on a more complex network due to the failure to account for sections of the route not covered by data collection activity.
- 11.5.4 In response to this, anonymous data collection methods such as mobile apps or Bluetooth surveys are being developed that go beyond traditional approaches and provide a variety of data types on the volume and characteristics of journeys at specific points. This data can then be used as a proxy for the usage on the surrounding area. It allows geographically distinct sources of data, collected on a network of routes, to be combined to estimate use across that network. This approach can generate a single annual usage estimate (broken down by user type) for a walking or cycling infrastructure scheme for both pre and post (where data permits) scheme construction.

<sup>3</sup> The online intervention diary provides a diary of infrastructure, softer measures (cycle training, events etc) and other factors that can affect cycling levels.

## 11.6. Output

11.6.1 The output from the analysis will need to be expressed clearly to communicate the findings to a range of stakeholders and its content and format should be set at the outset in the Monitoring and Evaluation Plan.

11.6.2 Options might reasonably be expected to include:

- measures of levels of walking and cycling
- measures of / change in
  - » levels of walking and cycling
  - » levels of walking and cycling among particular user groups
  - » levels of walking and cycling by particular trip type category
  - » perceptions of safety
  - » perceptions of facets of a route
  - » revenue-generation performance of a route
  - » health benefits associated with a route
  - » economic benefits associated with a route
- benefit to cost ratio of a route

11.6.3 Presentation of these results must have regard to the target audiences and be accessible to them. Whilst a detailed analysis may be appropriate for a more technically minded audience, a more visual representation of key results will be more suited to others, including decision makers and the general public.



## Key References

TRL (1999) Guidance on Monitoring Local Cycle Use, Report 395

TRL (1999) Research on Monitoring Local Cycle Use, Report 396

The Institution of Highways & Transportation (2000) Guidance for Providing for Journeys on Foot



Llywodraeth Cymru  
Welsh Government

# Appendix A

## Design Elements



## List of Design Elements

- DE001 – Footway
- DE002 – Footpath
- DE003 – Ramp
- DE004 – Steps
- DE005 – Raised Table Junction
- DE006 – Sinusoidal Hump
- DE007 – Cycle Bypass at Narrowing
- DE008 – Cycle-Only Access with Right Turn Facility
- DE009 – Segregated Contraflow Cycle Lane
- DE010 – Unsegregated Contraflow Cycling
- DE011 – Quiet Streets
- DE012 – Cycle Streets
- DE013 – Mandatory Cycle Lane
- DE014 – Advisory Cycle Lane
- DE015 – Cycle Lane Passing Car Parking/Loading
- DE016 – Cycle Lane at Side Road
- DE017 – Cycle Lanes with Removal of Centrelines
- DE018 – Cycle Lane with Light Segregation
- DE019 – Cycle Lane with Light Segregation at Side Road
- DE020 – Car Parking/Loading with Light Segregation
- DE021 – Hybrid Cycle Track
- DE022 – Hybrid Cycle Track at Side Road
- DE023 – Cycle Track Alongside Road, Separated from Pedestrians
- DE024 – Cycle Track Alongside Road, Shared With Pedestrians
- DE025 – Cycle Track at Side Road with Cycle Priority
- DE026 – Cycle Track at Side Road, Cyclists Give Way
- DE027 – Two-Way Cycle Track in Centre of Carriageway
- DE028 – Bus Stop: Cycle Lane Bypass
- DE029 – Bus Stop: Island Bus Stop
- DE030 – Bus Stop: Bus Boarder
- DE031 – Bus Stop: Shared Use
- DE032 – Cycle Track Away From Road, Separated From Pedestrians
- DE033 – Cycle Track Away From Road, Shared With Pedestrians
- DE034 – Transition Between Carriageway And Cycle Track
- DE035 – Bus Lane
- DE036 – Simple Uncontrolled Crossings (Walking, Shared Use or Cycle Only)
- DE037 – Cycle Priority Crossing
- DE038 – Uncontrolled Crossing With Central Refuge
- DE039 – Side Road Entry Treatment
- DE040 – Blended Side Road Entry Treatment
- DE041 – Central Median Strip
- DE042 – Zebra Crossing
- DE043 – Parallel Crossing for Pedestrians and Cyclists
- DE044 – Puffin and Ped-X Crossings
- DE045 – Toucan Crossing
- DE046 – Pedestrian/Cycle Bridge
- DE047 – Subway/Underpass
- DE048 – Wheeling Ramp
- DE049 – Unmarked Informal Junction
- DE050 – Advanced Stop Line
- DE051 – Cycle Bypass at Traffic Signals
- DE052 – Cycle Lanes Through Signalised Junction
- DE053 – Two Stage Right Turn at Traffic Signals
- DE054 – Mini Roundabout
- DE055 – Compact (“Continental”) Roundabout



## Notes:

1. These Design Elements provide concise guidance, including dimensioned drawings where appropriate, on the layout and use of particular types of design solution.

In order to enable authorities to gain experience in the use of more innovative techniques, as well as being able to apply more well-established solutions with confidence, each Design Element has been given one of three statuses, defined as.



### Standard Details

Details that are well understood and should generally be applied as shown unless there are particular reasons for local variation.



### Suggested Details

Details that have not been widely applied in Wales but may be considered appropriate for use in the circumstances as advised.



### Possible Details

Details that are largely untested in Wales but have been used successfully in other places and may be considered for use in pilot schemes to gain further experience.

Within this document those elements denoted as Standard Details will be regarded as “standards” for the purposes of section 3(6)(a) of the Active Travel Act.

The use of advice categorised as Suggested Details or Possible Details will require careful monitoring by the highway authorities who implement them. More details of monitoring processes can be found in Chapter 11.

2. The drawings and images provided are illustrative and will not cover all circumstances. They should be applied in the light of local context. Where appropriate references are given to other documents that will provide relevant advice, but readers should ensure that they any such documents are the current editions.
3. Advice indicated with an asterisk (\*) anticipates the coming into force of the revised Traffic Signs Regulations and General Directions (TSRGD), which is planned for March 2015. Until this document is published, special authorisation from Welsh Ministers will be required in order to comply with the guidance as written.

# DE001 Footway

## Measure and Brief Description

Footways provide routes for pedestrians within highways. A satisfactory footway of sufficient width is important to allow pedestrians to travel at their chosen speed and to pass one another safely. Footway widths may be increased by reallocating road space away from motor vehicles to pedestrians or increasing the usable width by removing street clutter. Footway provision for pedestrians is contingent on range of factors including the local context, static pedestrian activities such as seating or congregation near tourist attractions, crossing types, significant trip generators such as schools and workplaces, street clutter or pavement parking

## Benefits

- Provision of direct and safe movement space for pedestrians alongside carriageways and cycle tracks

## Key Design Features

- Surface materials should be even, firm and slip resistant in wet and dry conditions.
- Surface materials and layouts should be consistent in colour and tone, with good contrast between pedestrian routes, cycle tracks and carriageways.
- Manhole covers and service hatches should match surrounding material pavers and pavement treatments.
- Rest areas should be provided on a regular basis.
- Footways should normally be lit by the overall highway lighting system.

## Dimensions

- Should ideally be level with a desirable maximum longitudinal gradient of 5% (1 in 20).
- Absolute maximum longitudinal gradient of 8% (1 in 12.5).
- Cambers and crossfalls should preferably be 2.5% (1 in 40) and should not exceed 3.3% (1 in 30) and an absolute maximum of 10% (1 in 10) at crossings.
- Footways will normally be separated from carriageways by a kerb. The desirable minimum kerb height is 60mm, which can be reliably detected by a blind person.
- Minimum obstacle-free footway widths (a) are shown below. Where it is expected that there will be high volumes of pedestrians, widths should be increased accordingly – see Guidance on Pedestrian Comfort in Chapter 4.

Provision	a - Footway width (m)	Width can accommodate
Desirable minimum	2.0	Two wheelchairs or double buggies passing comfortably
Accepted minimum	1.8	Two pedestrians passing, one pedestrian passing a wheelchair or double buggy
Absolute minimum	1.5	Two wheelchairs or double buggies passing
Restricted width at immovable object	1.2	Provides space for a blind or partially sighted person to walk using a long cane, or with a guide dog, or alongside a person providing guidance.

- On roads with a speed limit of 40mph or above, or with over 1,500 HGVs AADT, it is desirable to allow an additional minimum of 0.5m of footway or verge width to allow for vehicle overhang and pedestrian 'kerb shyness'. There may also be a dead area of up to 0.5 m at the back of the footway where the footway is bounded by a vertical feature such as a wall, or by the entrances to buildings.
- Minimum headroom (b):
  - Desirable minimum - 2.3m.
  - Absolute minimum to isolated obstacles (eg signs) – 2.1m .

## Other Considerations

- Footways should be free of obstructions, with street furniture restricted to items which benefit pedestrians. These should be located in a street furniture zone out of the pedestrian flow, with adequate tactile and visual warning.
- Hazard protection (a detectable object, eg tapping rail or similar, with a minimum height 150 mm to underside)
  - Isolated objects, eg advertising boards, that cause an occasional narrowing of a footway, but which project no more than 100 mm from their base do not need hazard protection.
  - Where the base of the projection is less than 300 mm above ground level, no hazard protection is required.
  - Where an object projects more than 100 mm within a zone between 300 mm and 2.1 metres above ground level hazard protection should be provided. – See BS8300 for further details
- At dropped kerbs and at side-road junctions the appropriate tactile paving should be provided.

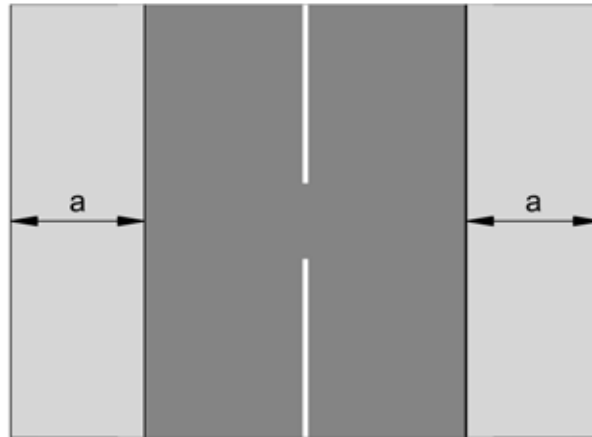
## Further References

- National Federation for the Blind (2013) - Access for Blind People in Towns. SS1401 (Circulated by DfT).
- Department for Transport (2005) – Inclusive Mobility.
- Department for Transport (2007) – Manual for Streets.
- British Standards Institution (2009/2010) - BS 8300:2009+A1:2010 Design of buildings and their approaches to meet the needs of disabled people. Code of practice.

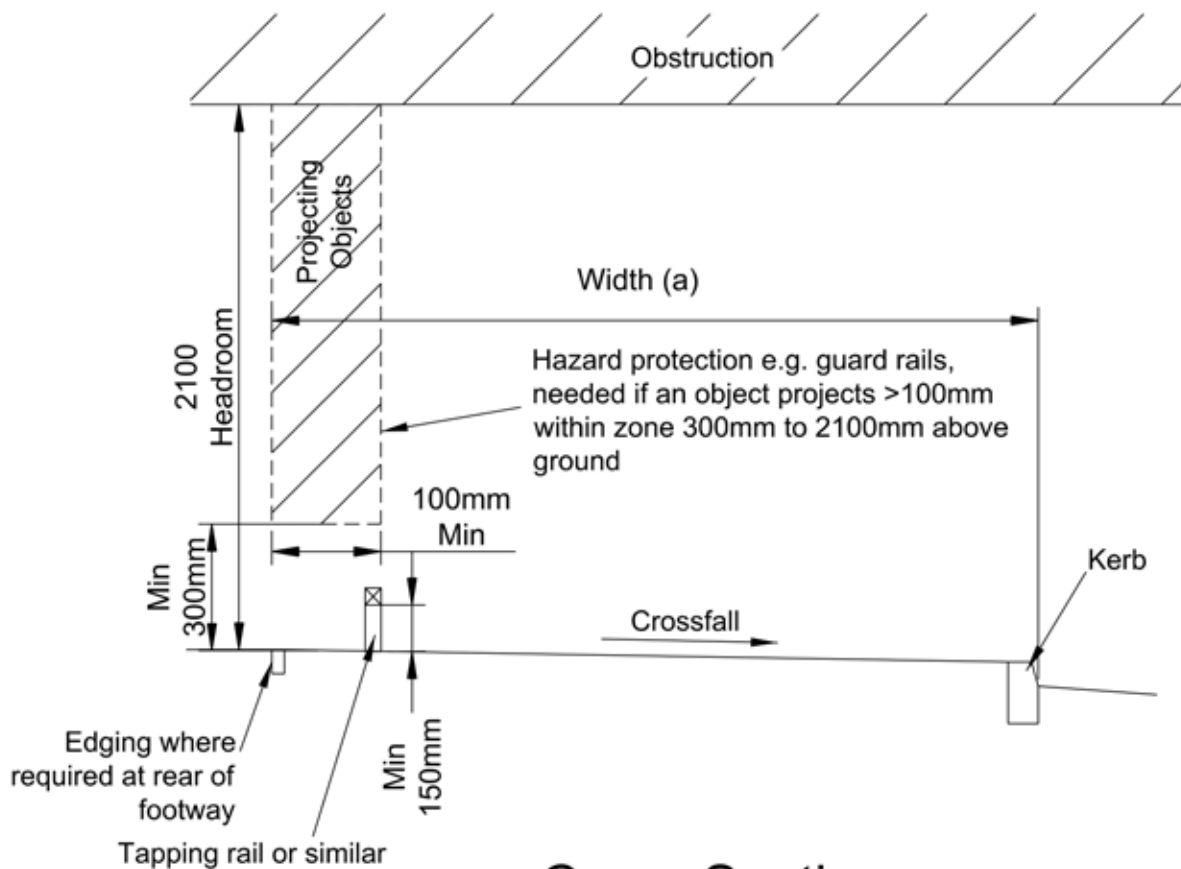


DE001

# Footway



Plan



Cross Section



Llywodraeth Cymru  
Welsh Government

Last Revised

September 2014

Do Not Scale Drawing

Drawing Produced By: Arup, 4 Pierhead Street, Capital Waterside, Cardiff, CF10 4QP

Copyright: Welsh Government

# DE002 Footpath

## Measure and Brief Description

Footpaths provide separate direct routes for pedestrians for journeys in a range of locations such as through housing developments or across open space and countryside. A satisfactory footpath of sufficient width is important to allow pedestrians to travel at their chosen speed and to pass one another safely.

## Benefits

- Provision of direct and safe movement of pedestrians typically linking footways

## Key Design Features

- Surface materials should be even, firm and slip resistant in wet and dry conditions
- Surface materials and layouts should be consistent in colour and tone, with good contrast between the footpath and any cycle track
- Manhole covers and service hatches should match surrounding material pavers and pavement treatments.
- Rest areas should be provided on a regular basis
- Footpaths should be lit where users might otherwise be discouraged from using the route outside daylight hours.

## Dimensions

- Should ideally be level with a desirable maximum longitudinal gradient of 5% (1 in 20)
- Absolute maximum longitudinal gradient of 8% (1 in 12.5)
- Cambers and crossfalls should preferably be 2.5% (1 in 40) and should not exceed 3.3% (1 in 30) and an absolute maximum of 10% (1 in 10) at crossings.
- Minimum obstacle-free footpath widths (a) are shown below. Where it is expected that there will be high volumes of pedestrians, widths should be increased accordingly – see Guidance on Pedestrian Comfort in Chapter 4.

Provision	a - Footway width (m)	Width can accommodate
Desirable minimum	2.0	Two wheelchairs or double buggies passing comfortably
Accepted minimum	1.8	Two pedestrians passing, one pedestrian passing a wheelchair or double buggy
Absolute minimum	1.5	Two wheelchairs or double buggies passing
Restricted width at immovable object	1.2	Provides space for a blind or partially sighted person to walk using a long cane, or with a guide dog, or alongside a person providing guidance

## Other Considerations

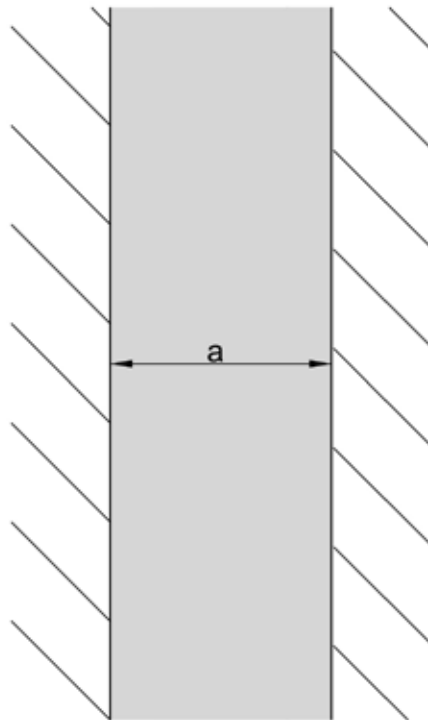
- Footpaths should be free of obstructions, with street furniture restricted to items which benefit pedestrians. These should be located in a street furniture zone out of the pedestrian flow, with adequate tactile and visual warning.
- Hazard protection (a detectable object, eg tapping rail or similar, with a minimum height 150 mm to underside)
  - Isolated objects, eg advertising boards, that cause an occasional narrowing of a footway, but which project no more than 100 mm from their base do not need hazard protection.
  - Where the base of the projection is less than 300 mm above ground level, no hazard protection is required.
  - Where an object projects more than 100 mm within a zone between 300 mm and 2.1 metres above ground level hazard protection should be provided. – See BS8300 for further details.

## Further References

- British Standards Institution (2009/2010) - BS 8300:2009+A1:2010 Design of buildings and their approaches to meet the needs of disabled people. Code of practice.

DE002

## Footpath



Footpath

Llywodraeth Cymru  
Welsh Government

Last Revised

September 2014

Do Not Scale Drawing

Drawing Produced By: Arup, 4 Pierhead Street, Capital Waterside, Cardiff, CF10 4QP

Copyright: Welsh Government

# DE003 Ramp

## Measure and Brief Description

Ramps (defined as a gradient of more than 5 % (1 in 20)) are provided to facilitate a change in level or grade on a walking route. They should only be used where a change in level or grade cannot be avoided. In many places ramps will provide the alternative access to stairs for wheelchair users.

## Benefits

- Ramps provide an accessible alternative to steps for disabled people, older people and parents and carers with pushchairs.

## Key Design Features

- Where the change in level is no more than 200mm a ramp may be used without alternative steps.
- Desirable Maximum Gradient – 5% (1 in 20).
- Absolute Maximum Gradient – 8% (1 in 12). Steeper ramps will cause difficulties for manual wheelchair users.
- Absolute Maximum Gradient over short distances (max 1m) - 10% (1 in 10) - eg on a ramp between a bus entrance and the pavement.

## Dimensions

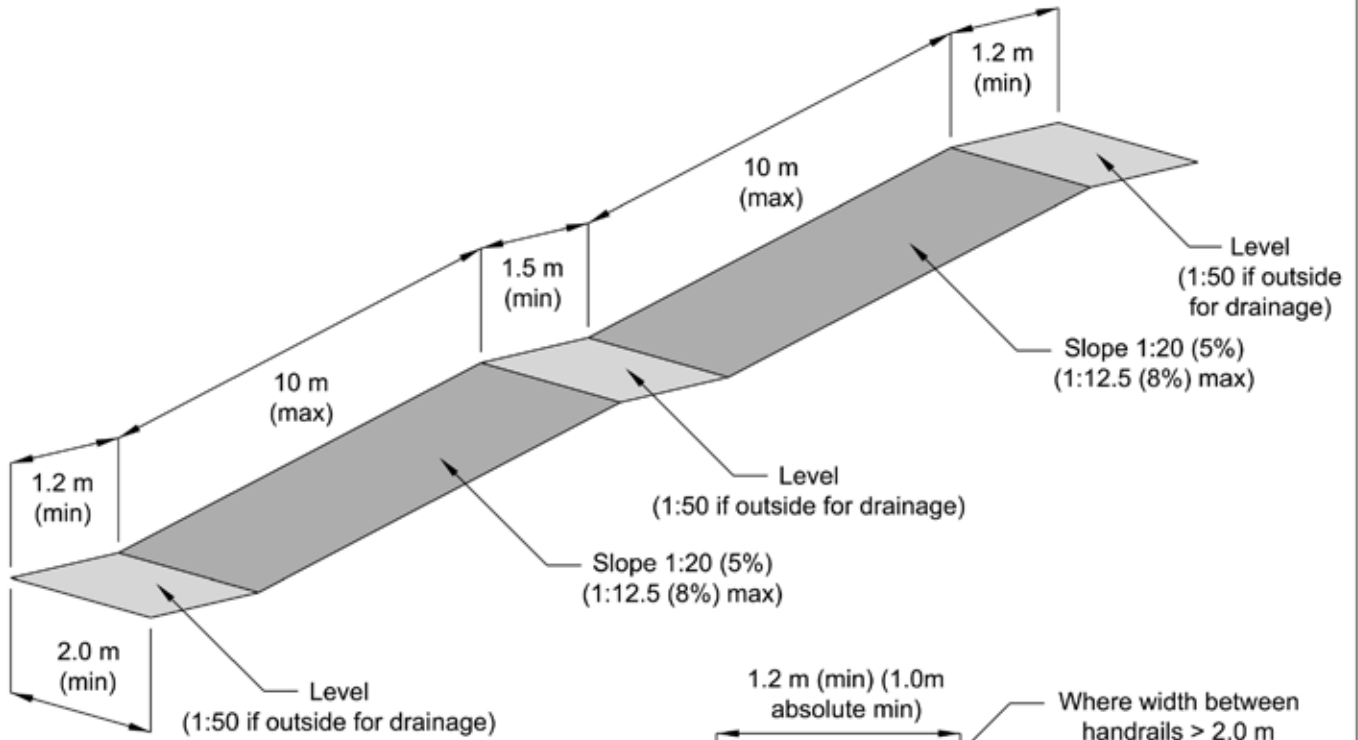
- Ramp surface width
  - » Preferred Minimum – 2m
  - » Desirable Minimum – 1.8m
  - » Absolute Minimum – 1.2m
- Sides of a ramp should be protected by a raised solid kerb at least 100mm in height.
- If kerb height exceeds 75mm there must be no slot or gap greater than 20mm in the range of 75mm to 150mm. This is done to avoid the possibility of the footplate of a wheelchair riding over the kerb or becoming trapped.
- Ramp-side face of the kerb to be flush with, or no more than 100mm away from, the ramp-side face of the handrail.
- Handrails should be provided on each side, with a minimum clear width rail to rail of 1,000mm. Where this unobstructed width exceeds 2000mm, a central, continuous handrail may be used as an alternative to a handrail on each side.
- Handrails should be provided on both sides of stairways and ramps and down the centre of stairs when their unobstructed width (ie between handrails) exceeds 1,800mm.
- Recommended height to the top of the principal handrail is between 900mm and 1000mm above the pitchline of the steps or above the surface of the ramp. On landings the top of the handrail should be between 900mm and 1100mm from the surface.
- Handrails should continue beyond the end of the ramp slope or end of the stairs by a (minimum) distance of 300mm and should either return to the wall or down to the floor or have a minimum rounded downturn of 100mm.
- Second, lower handrails for children and people of restricted growth are helpful and should be at heights of between 550mm and 650mm.
- The handrail itself should be smooth and comfortable to use by people with arthritic hands that is they should not be too small in diameter. Circular handrails should have a diameter between 40mm and 50mm; if not circular the handrail should be a maximum of 50mm wide by 38mm deep with rounded edges (radius of at least 15mm).
- There should be a clear space between the handrail and any adjacent wall of at least 50mm, preferably 60mm. Handrails should be supported centrally on the underside so there is no obstruction to the passage of the hand along the rail. There should also be a minimum of 600mm clear space above the handrail.

## Other Considerations

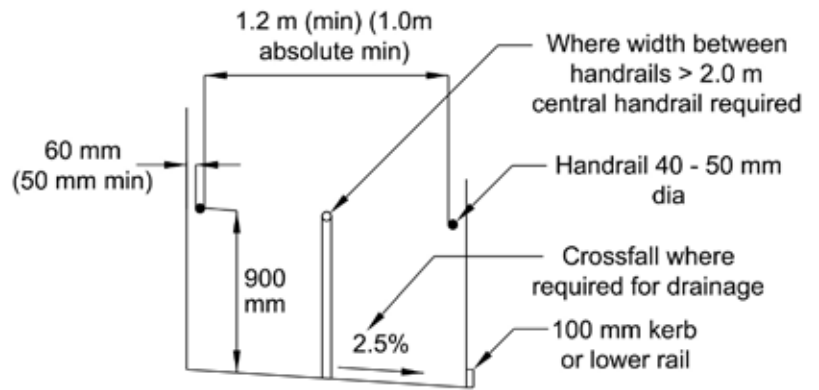
- There is a relationship between the length of a ramp and the gradient that people can manage; the longer the ramp the less severe the gradient that is feasible. One possible approach to this is, where a lengthy ramp is necessary, to design more frequent landings and lesser slopes for each successive segment.
- Ramps should never be longer than 132 metres in total and preferably no longer than 50 metres.
- Means should be provided to limit the risk of people colliding with the underside of freestanding ramps at any point where the clear height is less than 2.1m.
- The transition between the level and inclined parts of the ramp should be sufficiently rounded to ensure that a wheelchair user does not get caught by the foot supports.

## Further References

- Department for Transport (2005) – Inclusive Mobility.



Ramp key dimensions



Section through ramp



# DE004 Steps

## Measure and Brief Description

Steps allow direct movement for pedestrians from one level to another where there would otherwise be a significant gradient.

## Benefits

- Direct routes for pedestrians.
- Steps can provide a useful shortcut to maintain desire lines where it is necessary to also provide a ramp to accommodate a change in level or grade.
- Steps built within public spaces are particularly popular because they can also serve as a good lookout point.

## Key Design Features

- Steps should usually only be provided in conjunction with a ramp (or lift) in order to retain accessibility for disabled people, older people and parents and carers with pushchairs.

## Dimensions

- A riser height of 150mm can be managed by most people; a little more than this is possible if there are well designed handrails but 170mm should be regarded as the absolute maximum in most circumstances. Steps with very shallow risers can cause problems and should be avoided; 100mm is the absolute minimum. All steps in a flight must have the same dimensions.
- Tread depth or going should be 300mm deep (approximately the length of a size 9 shoe), with an absolute minimum of 250mm.
- The nose of the step should be rounded (6mm radius) without any overhang.
- Steps should be well lit (minimum 200 lux, see Section 11) and surfaced with a slip resistant material.
- Colour/tonal contrast on the step noses is beneficial for visually impaired people and should extend across the full width of each tread, 55mm deep on both tread and riser.
- The maximum number of risers in a flight should be 12, with resting places between successive flights. Resting places should have a Desirable Minimum length of 1.8m and an Absolute Minimum length of 1.2m, and be across the full width of the steps. The minimum number of steps in a flight should be three; fewer than this is less safe.
- The Desirable Minimum clear width between handrails is 1.2m which is sufficient for a disabled person and companion, with an Absolute Minimum width of 1m.
- Handrails should be provided on both sides and, where steps have a clear width of more than 1.8m, a centre handrail should also be provided.

## Other Considerations

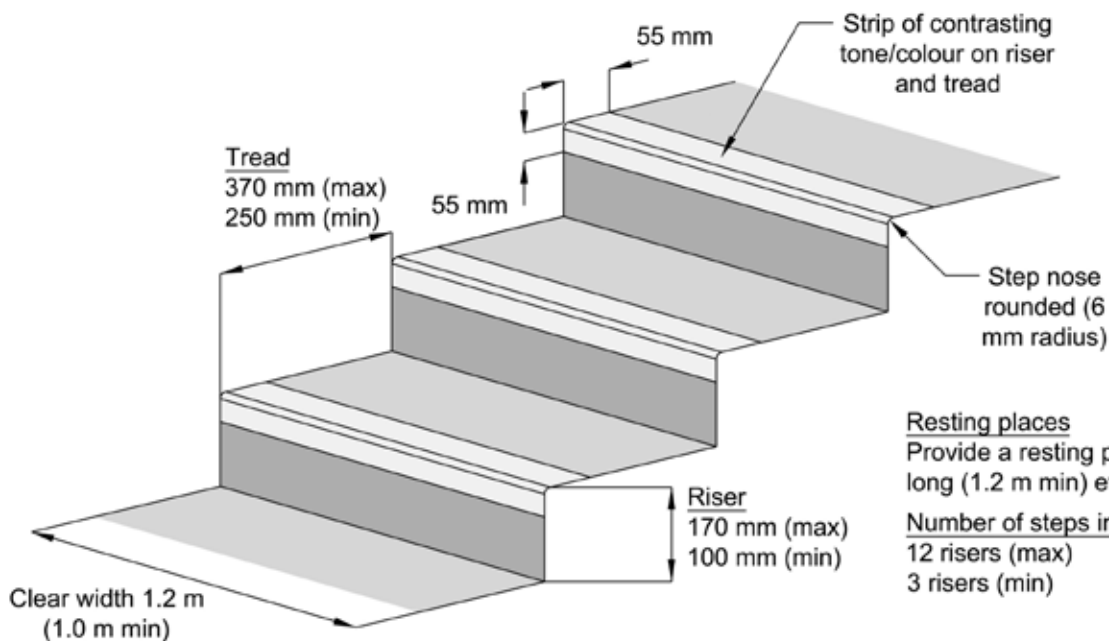
- Means should be provided to limit the risk of people colliding with the underside of freestanding steps at any point where the clear height is less than 2.1m.
- Incorporation of corduroy warning paving to the top and bottom, and visual contrast between elements should be used to highlight features such as steps edges and handrails.
- Open tread steps are to be avoided, as are curved or spiral steps.
- There should be unobstructed landing space at the top and bottom of each flight of steps of a length at least equal to the unobstructed width of the steps.

## Further References

- Department for Transport (2005) – Inclusive Mobility.

DE004

# Steps



Resting places

Provide a resting place (landing) 1.8 m long (1.2 m min) every 12 risers.

Number of steps in a flight

12 risers (max)  
3 risers (min)

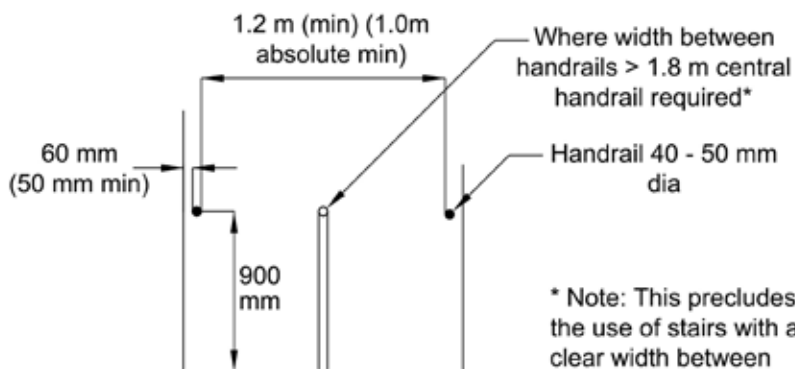
Pitch (angle) of steps

- 25° (min)
- 35° (max for high usage)
- 45° (absolute max)

Rule of thumb:

tread length + 2 x riser height = 600 mm

## Steps key dimensions



\* Note: This precludes the use of stairs with a clear width between 1.8 and 2.0 m

Section through steps



Llywodraeth Cymru  
Welsh Government

Last Revised

September 2014

Do Not Scale Drawing

Drawing Produced By: Arup, 4 Pierhead Street, Capital Waterside, Cardiff, CF10 4QP

Copyright: Welsh Government



# DE005 Raised Table Junction

## Measure and Brief Description

Raised table junctions create safer environments for all users by reducing the speed of vehicles negotiating the junction. They are typically used at priority junctions but can also be applied to roundabouts (including mini roundabouts and implied roundabouts) and traffic signals.

Raised table junctions can be used on roads with a speed limit of 30mph or less, with adequate street lighting provision, in the following situations:

- urban/suburban residential and mixed use areas; and
- in town centres as part of public realm improvements, where raised tables at key junctions provide informal crossing points for pedestrians.

Raised table junctions are road humps and must comply with the Highways Act 1980, Sections 90A to 90F.

## Benefits

- Raised tables emphasise the presence of a junction, encourage driver attention and lead to drivers giving informal priority to pedestrians.
- By reducing speeds, raised table junctions will commonly not require separate cycle facilities.
- The speed reduction effect of raised tables can be used to mitigate reduced visibility at some low volume/low speed junctions.
- Raised table junctions included as part of wider traffic calming measures can discourage through traffic.

## Key Design Features

- The raised table must comply with the Highways (Road Humps) Regulations 1999.
- The raised table should extend from kerb to kerb to benefit pedestrians crossing. This will require attention to drainage requirements to avoid standing water at the ramps.
- Appropriate tactile paving should be provided at pedestrian crossing points.
- Approach ramps should be located sufficiently far from the junction mouth so that the changing level of the carriageway does not become problematic for cyclists when turning.
- It may be necessary to install build outs, bollards or introduce parking restrictions as appropriate in order to prevent parking around the junction.
- Drainage covers/gully gratings set flush with the footway to avoid becoming a hazard for pedestrians and cyclists.

## Dimensions

- Approach ramps with a sinusoidal profile will reduce discomfort for cyclists compared to a 1 in 10 ramp.
- Table height should normally be 75mm, maximum 100mm.
- Kerb radii to be reduced to 2-3m, subject to vehicle tracking (and allowing for vehicles to cross centrelines unless flows are high).

## Other Considerations

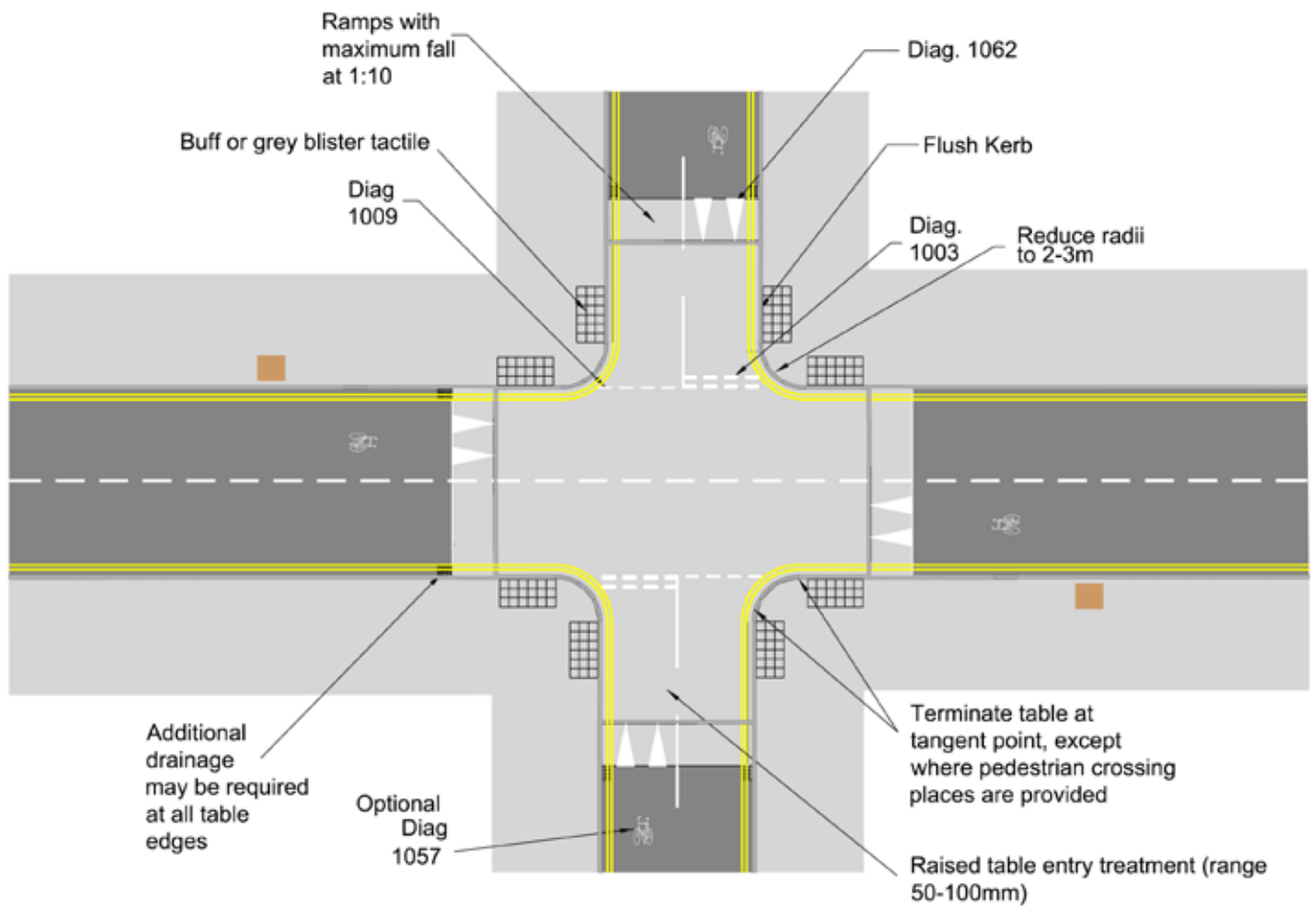
- Bollards may be provided to prevent over-run on corners.
- Strengthened corners may be necessary if over-run is to be expected.
- Raised tables can usefully be provided between junctions, using similar design criteria.

## Further References

- Department for Transport (2007) – Local Transport Note 01/07. Traffic Calming.

DE005

## Raised Table Junction



Llywodraeth Cymru  
Welsh Government

Last Revised

September 2014

Do Not Scale Drawing

Drawing Produced By: Arup, 4 Pierhead Street, Capital Waterside, Cardiff, CF10 4QP

Copyright: Welsh Government

# DE006 Sinusoidal Hump

## Measure and Brief Description

Traffic calming measures are used to reduce motor vehicle speeds thereby improving safety for pedestrians and cyclists as well as improving living conditions for residents living along traffic calmed routes. The provision of sinusoidal profile humps reduces the discomfort for cyclists when riding over humps, whilst still being effective in reducing traffic speed.

Sinusoidal humps are road humps and must comply with the Highways Act 1980, Sections 90A to 90F.

## Benefits

- Sinusoidal road humps minimise discomfort for passing cyclists and are effective at reducing motor-vehicle speeds.
- Improve perceived and actual safety for pedestrians and cyclists.
- Reduction in traffic speeds helps improve cyclist comfort and help create suitable cycle routes .
- Helps reduce the necessity for speed limit enforcement by Police.
- Can improve living conditions for residents living along traffic calmed roads.

## Key Design Features

- The sinusoidal road hump must comply with the Highways (Road Humps) Regulations 1999.
- As an exact profile may be difficult to construct an approximate sinusoidal profile is acceptable, with a tapered entry and exit profile.
- The impacts on car parking should be considered.

## Dimensions

- Hump height should normally be 75mm, maximum 100mm, see also Local Transport Note 1/07.

## Other Considerations

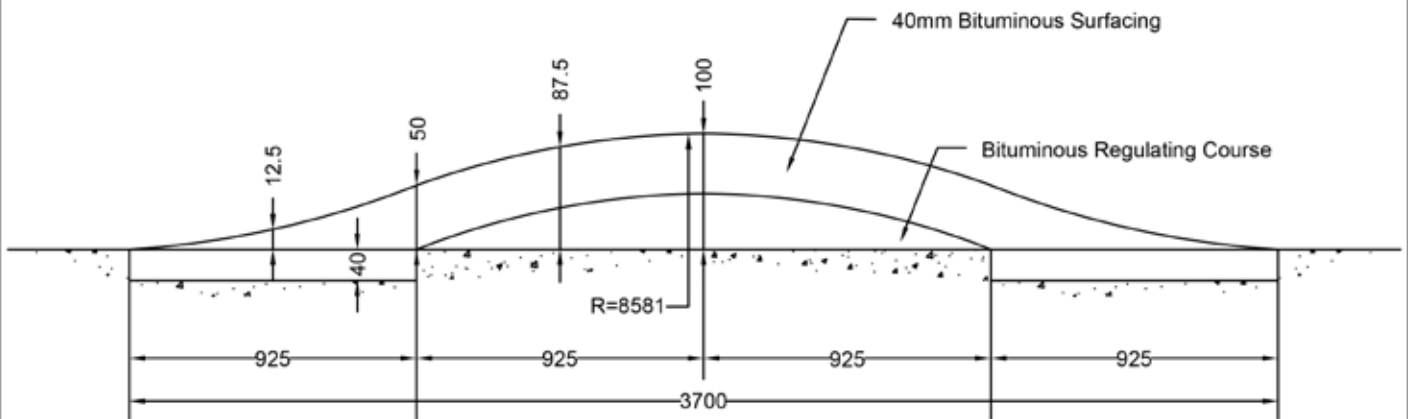
- Where a drainage gap is provided at the edge of a sinusoidal hump it should not be wide enough that drivers use it.
- Councils are required to advertise and consult on sinusoidal humps, flat-top humps and speed cushions under the Highways (Road Hump) Regulations 1999.

## Further References

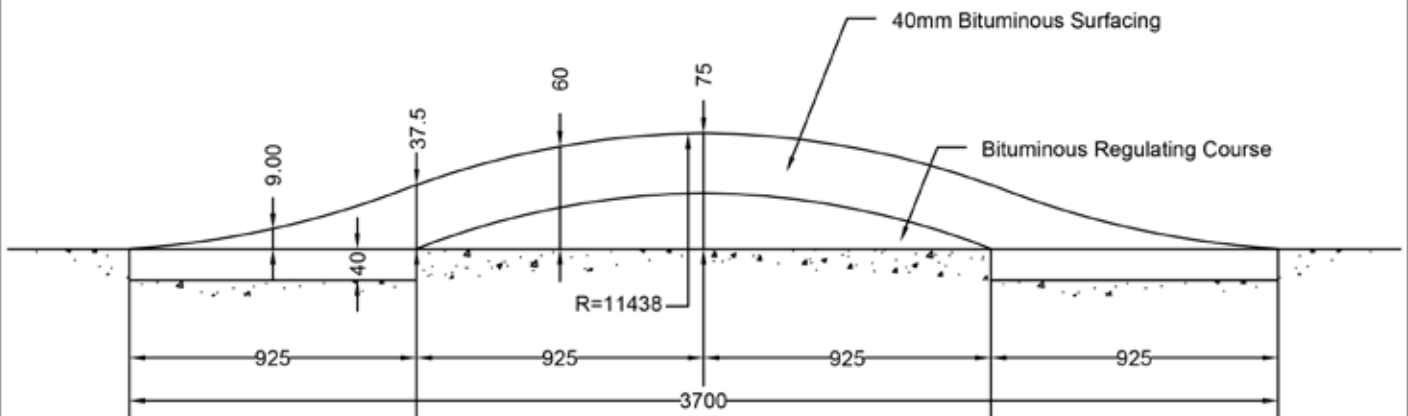
- Department for Transport (2007) – Local Transport Note 01/07. Traffic Calming.

DE006

## Sinusoidal Hump



A. 100mm High Hump



B. 75mm High Hump

## Notes:

Flexible construction is shown but other materials could be used, for example pre-cast concrete

R = Radius of sinusoidal hump

All dimensions are in mm



Llywodraeth Cymru  
Welsh Government

Last Revised

September 2014

Do Not Scale Drawing

Drawing Produced By: Arup, 4 Pierhead Street, Capital Waterside, Cardiff, CF10 4QP

Copyright: Welsh Government

# DE007 Cycle Bypass at Narrowing

## Measure and Brief Description

Traffic calming measures are used to reduce motor vehicle speed thereby improving safety for pedestrians and cyclists as well as improving living conditions for residents living along traffic calmed routes. Traffic calming can improve cycling conditions, but where poorly designed it can also be uncomfortable and in some cases be intimidating and dangerous. Where horizontal traffic calming features are provided consideration should be given to providing bypasses for cyclists.

## Benefits

- Cyclists are not intimidated or squeezed by motor traffic.
- Improve perceived and actual safety for pedestrians and cyclists.
- Reduction in traffic speed helps improve cyclist comfort and create suitable cycle routes.
- Helps reduce the necessity for speed limit enforcement.
- Can improve living conditions for residents living along traffic calmed roads.

## Key Design Features

- Cycle bypass exits should not require cyclists to merge abruptly with motor vehicles.
- Parking and loading/waiting restrictions should be provided to avoid cycle bypasses becoming blocked by vehicles.
- Careful consideration should also be given to drainage at cycle by-passes to minimise gully grate conflict and flooding in the area.
- Bypasses should be wide enough to facilitate maintenance, e.g. street sweeper vehicles.

## Dimensions

- a - cycle bypass to traffic calming features to be 2m desirable min (1.5m absolute minimum).
- b - gap for traffic between traffic calming features to be 3m max.
- c - avoid pinch point distances of between 3.1 - 3.9m – see Table 4.6.

## Other Considerations

- Bypasses should desirably be at carriageway level, in which case regular sweeping will be necessary.
- Footway level bypasses should consider impact on pedestrians, and additional drainage will be required.

## Further References

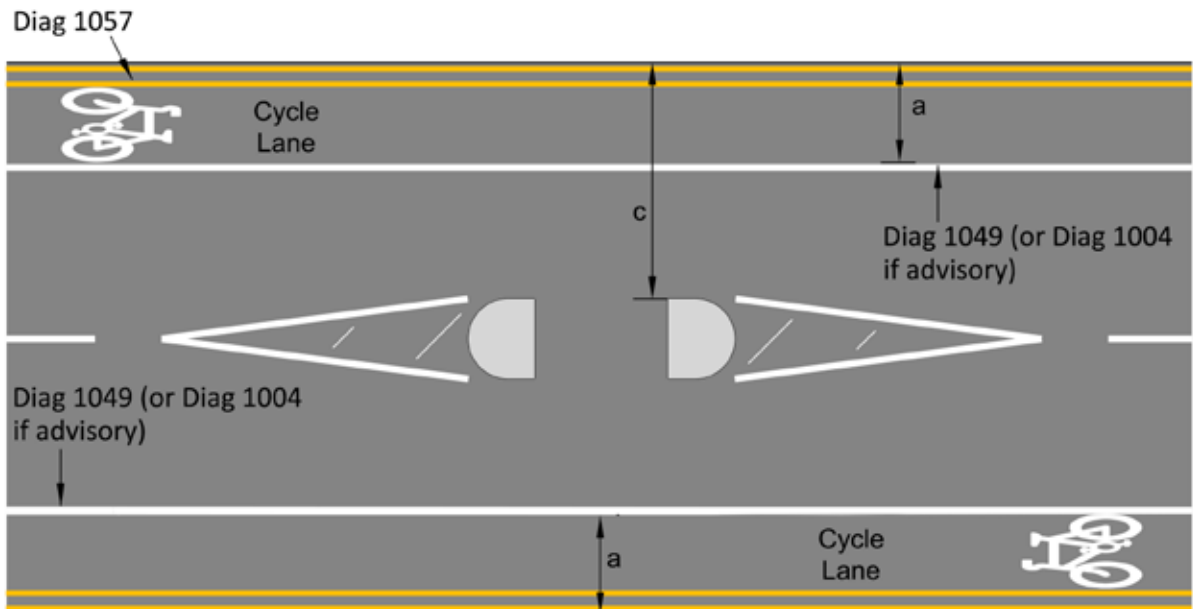
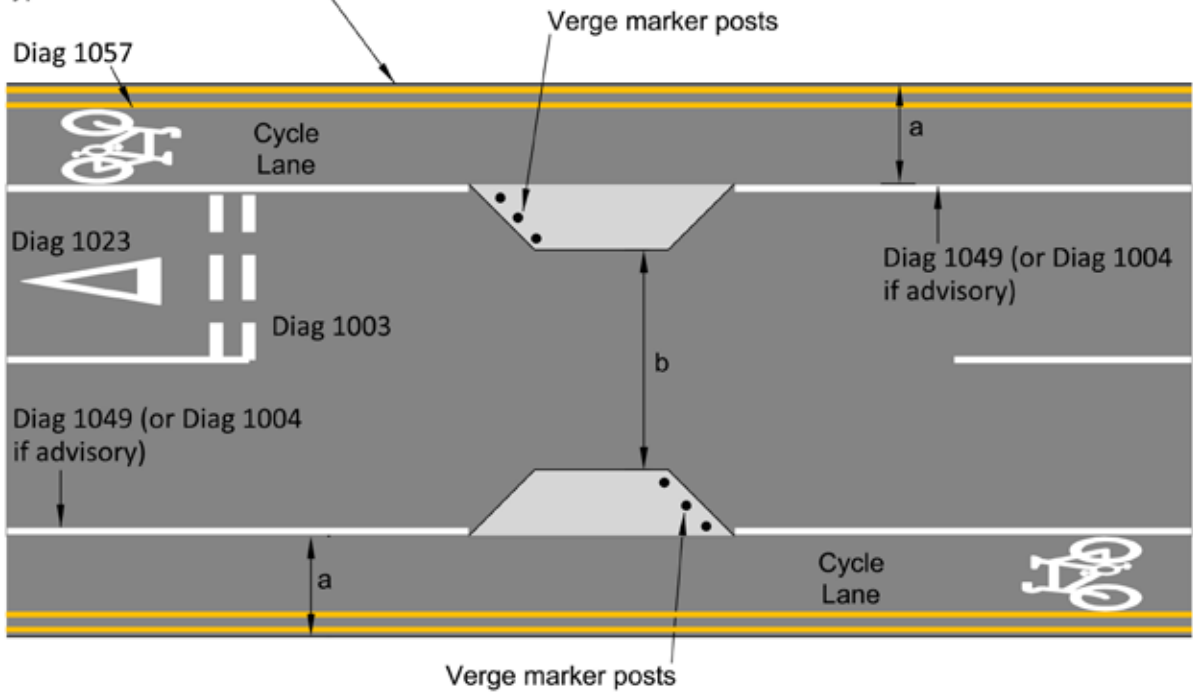
- Department for Transport (2007) – Local Transport Note 01/07. Traffic Calming.

DE007

# Cycle bypass at Narrowing



Provide kerb-face inlet gullies if bypass is narrower than 2m



Llywodraeth Cymru  
Welsh Government

Last Revised

September 2014

Do Not Scale Drawing

Drawing Produced By: Arup, 4 Pierhead Street, Capital Waterside, Cardiff, CF10 4QP

Copyright: Welsh Government

# DE008 Cycle-Only Access with Right Turn Facility

## Measure and Brief Description

Cyclists should be exempted from restrictions applied to motor traffic on links or at junctions where safe to do so, or through the creation of short connections which are only available to cyclists and pedestrians, to give them time and distance advantages. This example shows how a cycle-only access can be provided which includes a central lane to assist right-turning cyclists.

## Benefits

- Reduces cycle journey times.
- Increase permeability of area for cyclists.
- Provide convenient and attractive routes.
- Helps to limit motor vehicle through traffic, and particularly effective in neighbourhoods where extraneous traffic is a problem, helping to deter unnecessary car trips.
- Relatively low cost.
- Can be retro-fitted to existing streets.

## Key Design Features

- Traffic movements are often banned to help ease congestion by deterring traffic from certain streets. It is possible to exempt cycles from turning bans without having to significantly change the physical nature of the road.
- Where a closure is planned the preferred method is by the use of bollards with cycle signing mounted on them.
- Demountable bollards can be used to retain access for emergency vehicles. Dedicated right turn pockets for cyclists provide protection whilst waiting to make a turn.

## Dimensions

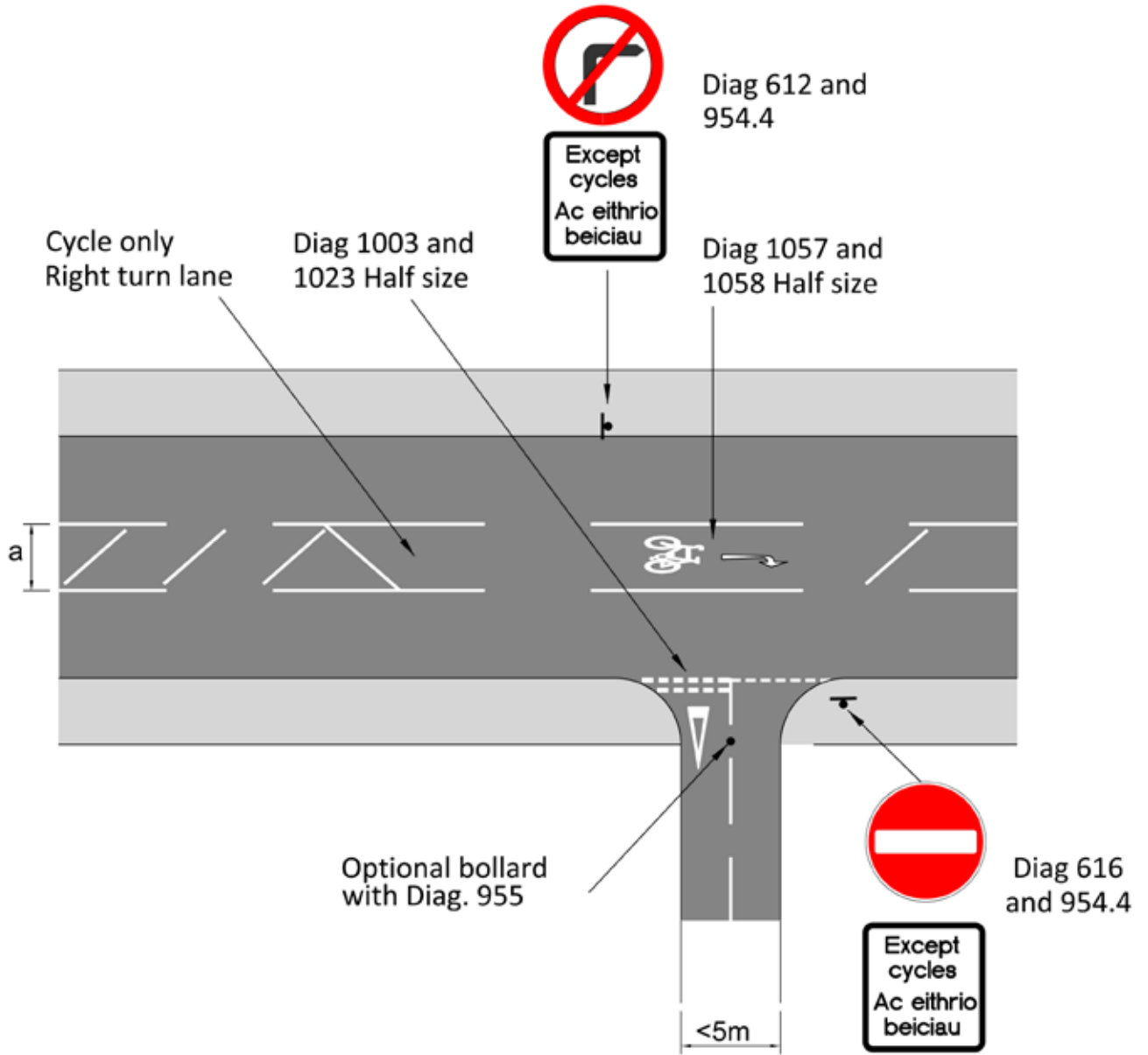
- a - dedicated right turn pockets for cyclists to be 2m desirable min (1.5m absolute minimum).
- Width for cyclists at road closure to be 1.5m absolute minimum.

## Other Considerations

- Consideration should be given to:
  - » The potential for nuisance caused by powered two wheelers.
  - » Need to restrict car parking in the vicinity of the cycle gap, eg through double yellow lines.
  - » Providing good natural surveillance to deter crime.
  - » Potential need to maintain access for emergency vehicles.
  - » Pedestrian and cyclist interaction.
- Build outs or other features may be needed to keep the cycle gap clear of parked vehicles.
- The impact of road closures can be assessed by undertaking a trial closure on a temporary basis. The closure can then be made permanent if it is found to be successful.



DE008 Cycle - Only Access with Right Turn Facility



Llywodraeth Cymru  
Welsh Government

Last Revised

September 2014

Do Not Scale Drawing

Drawing Produced By: Arup, 4 Pierhead Street, Capital Waterside, Cardiff, CF10 4QP

Copyright: Welsh Government

# DE009 Segregated Contraflow Cycle Lane

## Measure and Brief Description

The permeability of the road network for cyclists can be greatly enhanced by exempting them from one-way restrictions. This provides connections that are only available to cyclists and reduces their travel times and distances. Segregated contraflow cycling can be provided by using a cycle lane - either mandatory or advisory - or with physical separation.

## Benefits

- Improves cycle journey directness.
- Enables cyclists to avoid longer routes on busy roads.
- Gives cycling an advantage over motor traffic.
- Likely to reduce the number of cyclists riding on the footway.
- In one-way streets contraflow cyclists have better vision of people exiting parked vehicles facing towards them.
- Affordable and relatively straightforward to introduce.

## Key Design Features

- Mandatory cycle lane should be used in preference to advisory cycle lanes where space permits.
- Advisory lanes may be a suitable option where oncoming vehicles need to encroach into the cycle lane, eg to pass obstructions.
- An advisory lane can be considered the 85th percentile speed is less than 25 mph or traffic flows are below 1,000 veh AADT.
- Physical segregation may be appropriate where motor vehicle speeds and/or volumes are high, in the form of kerb separation or light segregation.
- Where kerb separation is provided, gaps should be used to allow cyclists access to the carriageway and junctions.
- Where contraflow lanes pass parked cars a 0.5m wide buffer zone should be provided.
- Entry points for general traffic should preferably be provided with an island with sufficient cycle gap that will not be blocked by parked vehicles, as it gives added protection to cyclists against turning vehicles.
- 1057 cycle symbols should be used at entrances/exits and across side roads to alert drivers of likely cycle movements.
- 'Except cycles' signs with 'No Entry' signs should be used rather than the 'No Motor Vehicle' sign (Diagram 619)\*.

## Dimensions

- Cycle lane width (a):
  - » with mandatory or advisory lane or light segregation: 2m desirable minimum, 1.5m absolute minimum.
  - » with physical segregation: 2m minimum.

## Other Consideration

- Contraflow cycle lanes should be designed to general guidance and standards for cycle lanes, including where they pass side road junctions.
- Traffic calming features that require contraflow cyclists to change their alignment should be avoided, for example speed cushions and build-outs.
- Waiting and loading restrictions should be included in TROs for contraflow lanes to prevent parked vehicles obstructing the lane and pushing cyclists into oncoming traffic.
- Echelon parking bays should be angled so that drivers reverse into them, so that they exit facing forwards and towards contraflow cyclists, therefore improving visual contact.
- Authorities may choose to omit vertical signs to diagram 960.1 and 960.2 when the speed limit is 20mph and the contraflow cycle lane is clearly visible.\*

## Further References

- Department for Transport (2003) – Traffic Signs Manual Volume 3. Road Markings.

DE009

# Segregated Contraflow Cycle Lane



Diag 1003 Half size

Diag 1009



Diag 960.1



Diag 960.1

Diag 610 mounted on illuminated bollard



Diag 1023 Half size

Diag 1049 or diagram 1004

Diag 1057 at intervals no greater than 75m.



Diag 955 and Diag 960.1 mounted back to back at intervals no greater than 75m.

Diag 1059

Diag 1038



Diag 960.1 at intervals no greater than 75m.

Diag 1023



Diag 616 and Diag 954.4

Except cycles  
Ac eithrio beiciau

Diag 1009 Half size

Diag 1003



Llywodraeth Cymru  
Welsh Government

Last Revised

September 2014

Do Not Scale Drawing

Drawing Produced By: Arup, 4 Pierhead Street, Capital Waterside, Cardiff, CF10 4QP

Copyright: Welsh Government

# DE010 Unsegregated Contraflow Cycling

## Measure and Brief Description

The permeability of the road network for cyclists can be greatly enhanced by exempting them from one-way restrictions. This provides connections that are only available to cyclists and reduces their travel times and distances. On less busy one-way roads with a narrow width two-way cycling may be permitted without a cycle lane.

## Benefits

- Improves cycle journey directness.
- Enables cyclists to avoid longer routes on busy roads.
- Gives cycling an advantage over motor traffic.
- Likely to reduce the number of cyclists riding on the footway.
- In one-way streets contraflow cyclists have better vision of people exiting parked vehicles facing towards them.
- Affordable and relatively straightforward to introduce.
- Can be introduced without a cycle lane where traffic volumes and speeds are low.

## Key Design Features

- Mandatory cycle lane should be used in preference to advisory cycle lanes where space permits.
- Where the 85th percentile speed is less than 25 mph and traffic flows are below 1,000 veh AADT, or where the street forms part of a 20 mph zone.
- At entries and exits, consideration should be given to alert drivers and pedestrians of contraflow cycle movements using a short section of cycle lane.
- Cycle logos and directional arrows should be used especially at entrances/exits and across side roads to alert drivers of likely cycle movements.
- 'Except cycles' signs with 'No Entry' signs should be used rather than the 'No Motor Vehicle' sign (Diagram 619)\*.

## Dimensions

- Sufficient carriageway space is required to ensure cyclists have enough space to pass oncoming vehicles, however it is possible to facilitate contraflow cycling in lightly trafficked narrow streets, including where there is car parking on one or both sides and a narrow running lane.
- a - carriageway width:
  - » Absolute minimum 2.6m (no car parking).
  - » Desirable minimum 3.85m based on car passing cycle (no car parking).
  - » Absolute minimum 4.6m (with car parking on one side).

## Other Considerations

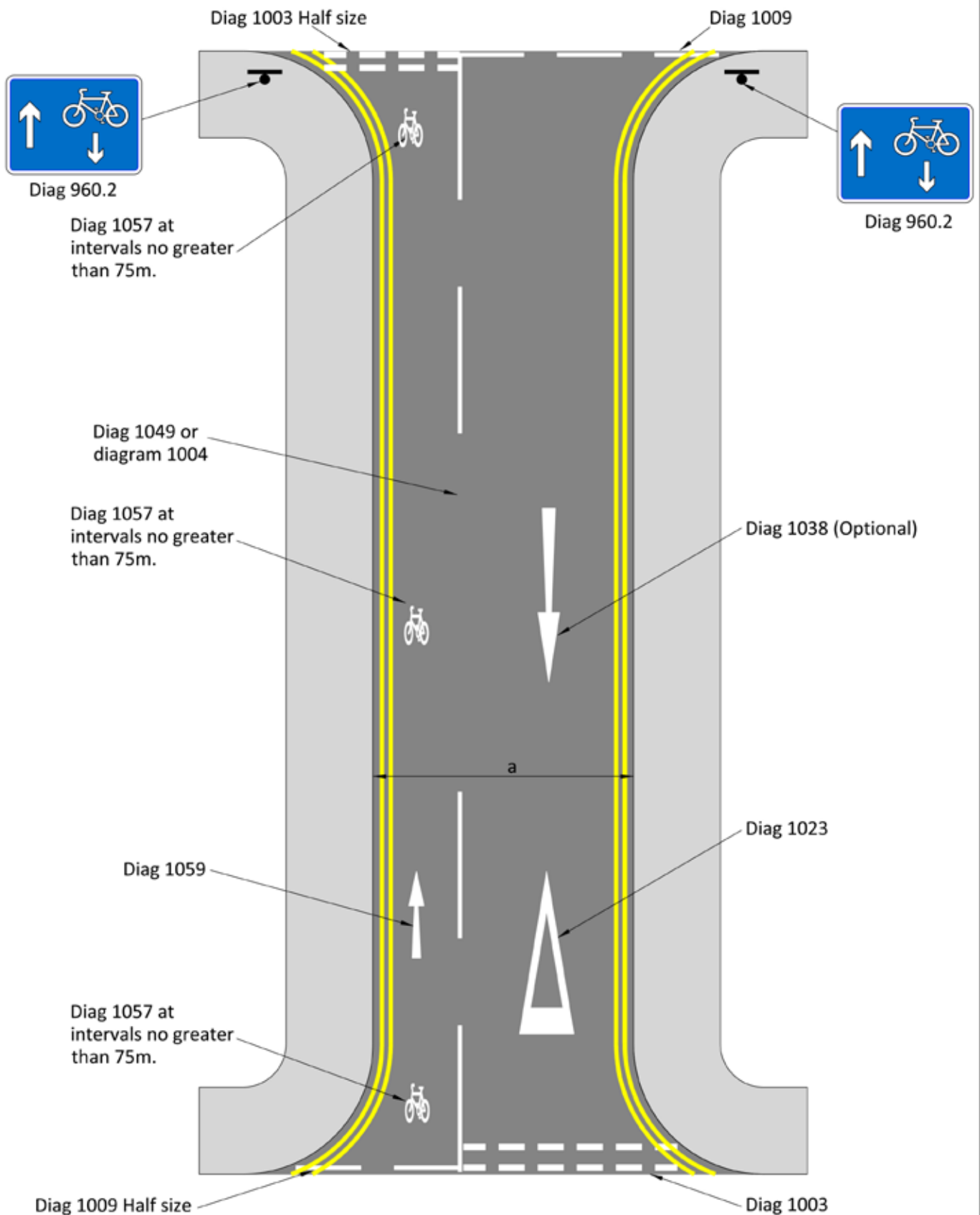
- 20mph zone with traffic calming or 20mph limit is desirable.
- Traffic calming features that require contraflow cyclists to change their alignment should be avoided, for example speed cushions and build-outs.
- Echelon parking bays should be angled so that drivers reverse into them, so that they exit facing forwards and towards contraflow cyclists, therefore improving visual contact.
- Any car parking should preferably be on the opposite side of the carriageway to contraflow cyclists.
- However, where widths are very restricted, car parking on the cyclists' side will enable cyclists to wait in gaps between parked cars to avoid larger oncoming vehicles.

## Further References

- Department for Transport (2003) – Traffic Signs Manual Volume 3. Road Markings.

DE010

# Unsegregated Contraflow Cycling



Llywodraeth Cymru  
Welsh Government

Last Revised

September 2014

Do Not Scale Drawing

Drawing Produced By: Arup, 4 Pierhead Street, Capital Waterside, Cardiff, CF10 4QP

Copyright: Welsh Government

# DE011 Quiet Streets

## Measure and Brief Description

Quiet Streets is a term given to urban cycling routes on low traffic speed and volume back streets, which are particularly suitable for new and less confident cyclists. Routes should maintain continuity for cycling and tackle physical barriers such as busy junctions, narrow paths, and should minimise diversions away from desire lines.

Cycle symbols to Diagram 1057, without necessarily the use of vertical signs to diagram 967, can be used to sign the continuity of cycle routes and indicate the correct positioning for cycling within the carriageway; in doing so they also help to raise motorist's awareness of cyclists, encouraging them to give cyclists space\*.

## Benefits

- Continuous direct routes for cycling following desire lines.
- Relatively low cost solution.
- Largely un-segregated from motor traffic but segregation can be used when required.
- Secure and perceived as secure (socially safe).

## Key Design Features

- Routed generally via lightly-trafficked roads (less than 2,500 vehicles AADT on primary cycle routes and 5000 vehicles AADT on secondary cycle routes) and very limited HGV traffic.
- Where traffic volume levels exceed these values, traffic reduction or a filtered permeability approach should be used to reduce motor vehicle volume.
- Traffic speeds to be low – average below 20mph.
- Diag 1057 can be useful to improve legibility of the route where needed.
- Points of conflict with oncoming and crossing traffic, parked vehicles and loading bays (kerbside activity) should be minimised.
- Minimise overall delays and provide route continuity and safety by prioritising cycle movements at junctions.

## Dimensions

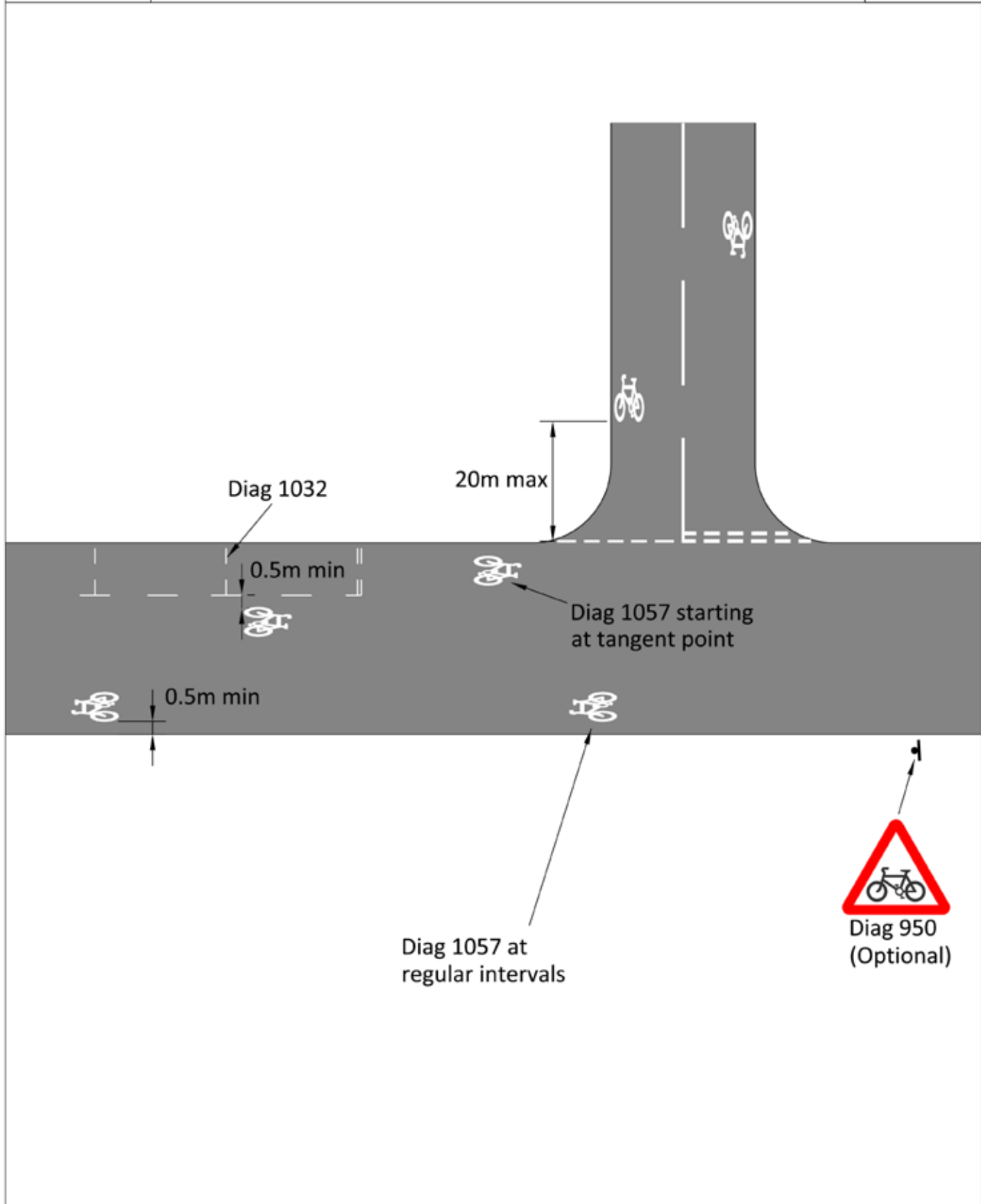
- Where 1057 markings are provided to highlight the route they should be spaced at regular intervals.

## Other Considerations

- Although TSRGD strictly requires the use of vertical signs to diagram 967 with diagram 1057 markings, authorities may choose to only place signs where there is a clear need to alter other road users to the presence of a cycle route\*.

DE011

# Quiet Streets



Llywodraeth Cymru  
Welsh Government

Last Revised

September 2014

Do Not Scale Drawing

Drawing Produced By: Arup, 4 Pierhead Street, Capital Waterside, Cardiff, CF10 4QP

Copyright: Welsh Government



# DE012 Cycle Streets

## Measure and Brief Description

A Cycle Street is a Quiet Street which also serves as a Primary Cycle Route. It should carry low levels of low speed motor traffic, high levels of cycling, and provide cyclists with a level of service comparable to that provided by a high quality traffic free route the objectives of a Cycle Street are to:

- Present a legible design recognisable to all types of user as a main cycle route.
- Influence behaviour so that cyclists assume priority over motor vehicles.
- Maintain priority for cyclists.
- Attract experienced cyclists as well as less confident cyclists.

In the consultation documents issued with the Draft TSRGD 2015, the Department for Transport proposed that traffic signs and orders could be applied to Cycle Streets which would:

- Ban the overtaking of cyclists by motor vehicles.
- Indicate an advisory 15mph limit.

Highway authorities that wish to apply these measures should seek authorisation from Welsh Government.

## Benefits

- Improved cyclist safety and subjective safety.
- Improved route legibility.

## Key Design Features

- Street design should encourage cyclists to assume priority, with motor vehicles travelling slowly and not overtaking them.
- There is no standard design; design approaches should be creative, easily maintainable and adaptable – the design detail provided is one indicative solution; the street must be physically recognisable, including from side roads.
- Cyclists should have priority along links and at junctions to increase convenience.
- The length over which a car has to follow a cyclist should be limited to between 200m and 400m.
- Street should carry no more than 2,500 motor vehicles AADT.
- Where traffic volume levels exceed these values, traffic reduction or a filtered permeability approach should be used to reduce motor vehicle flows.
- Traffic speeds to be low – average below 20mph.

## Dimensions (Illustrative design)

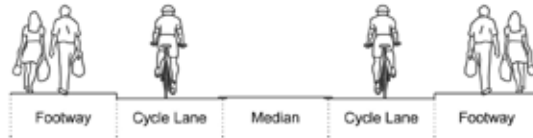
- a – traffic lane width 1.5m absolute minimum, 3m absolute maximum.
- b - central median, 1m desirable minimum.
- Where diagram 1057 markings are provided the route they should be spaced at regular intervals.

## Other Considerations

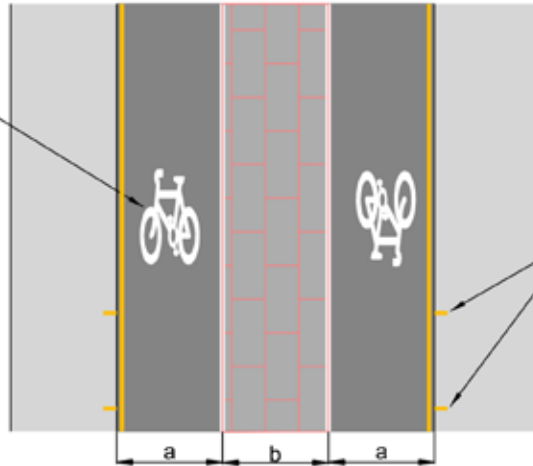
- Although TSRGD strictly requires the use of vertical signs to diagram 967 with diagram 1057 markings, authorities may choose to only place signs where there is a clear need to alter other road users to the presence of a cycle route\*.

DE012

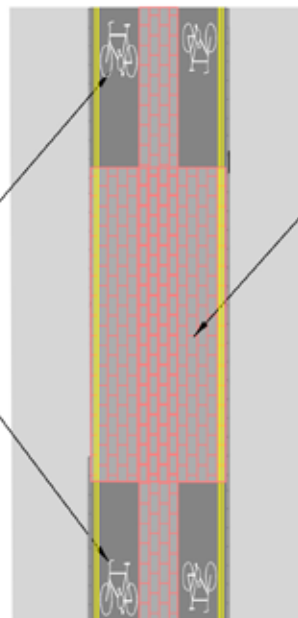
# Cycle Streets



Diag 1057



Large Diag. 1057  
At regular intervals



Llywodraeth Cymru  
Welsh Government

Last Revised

September 2014

Do Not Scale Drawing

Drawing Produced By: Arup, 4 Pierhead Street, Capital Waterside, Cardiff, CF10 4QP

Copyright: Welsh Government

# DE013 Mandatory Cycle Lane

## Measure and Brief Description

Mandatory cycle lanes define an area of the carriageway that is reserved for cyclists and are suitable for roads where the speed limit is 30mph or less. Mandatory lanes are marked with a continuous white line (Diagram 1049) which prohibits vehicles from entering the lane during the hours of operation, which should normally be at all times. There can be exceptions, such as emergency service vehicles and access to private driveways. Parking and loading should also be prohibited through appropriate controls. Mandatory lanes are preferable to advisory lanes and should be used unless there are particular local circumstances preventing their use. Following the coming into force of the revised TSRGD in March 2015, it is anticipated that mandatory cycle lanes will not require Traffic Regulation Orders to be made, but until then TROs are necessary.

## Benefits

- For exclusive use by cyclists during hours of operation (normally at all times).
- Delineated by solid white line, which is less likely to be crossed by motor vehicles.
- Can be enforced by the Police.
- Reduces the potential for conflict between motor vehicles and cycles compared to an advisory lane.
- Highlights presence of cyclists.
- Reduced lane width for motor traffic likely to reduce traffic speeds.

## Key Design Features

- Continuity of cycle lane essential.
- Solid white delineation line 150mm wide (Diagram 1049).
- Cycle symbol markings (diagram 1057) should be placed at the start of the lane and after every break, as well as at regular intervals on long uninterrupted lengths.
- TRO required (Note – it is expected that this requirement will be removed in the revised TSRGD, which is planned for 2015).
- Lanes should operate at all times.
- Waiting and loading restrictions should apply at all times.

## Dimensions

- a - Desirable minimum 2m, Absolute minimum 1.5m.
- Cycle lane entry taper 1:10, exit taper 1:5.

## Other Considerations

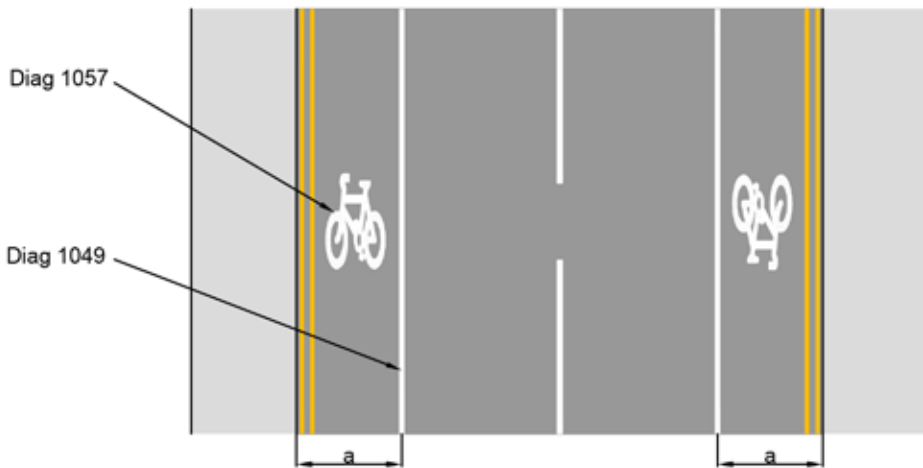
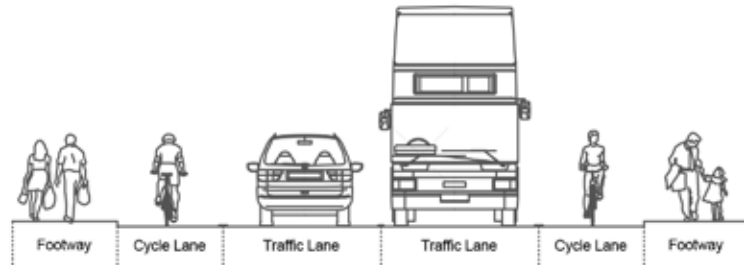
- Mandatory lanes must be discontinued at side road junctions but the use of a short length marking to diagram 1010\* preserves continuity.
- Mandatory lanes can be continued across private accesses.
- Additional protection of cycle lanes can be provided using hatched road markings and traffic islands.
- A cyclist riding in the 'secondary' position will fill a 1.5m cycle lane, so if this width cannot be provided a cycle lane is unlikely to be appropriate.
- Inadequate cycle lane widths may increase conflict risk because drivers do not realise that cyclists need to move away from the kerb to avoid surface hazards. A narrow cycle lane may also give motorists (misplaced) confidence to provide less clearance while overtaking than they would in the absence of a cycle lane.
- Greater width should be considered on uphill cycle lanes to allow for additional lateral movement.
- A single uphill cycle lane is preferable to two sub-standard lanes.
- Cycle lanes constrain cyclists to the margin of the carriageway and so cycle-friendly gully gratings are essential.
- Authorities may choose to only place vertical signs to diagram 959.1 with each diagram 1057 marking where there is a clear need to alert other road users to the presence of the mandatory lane.\*

## Further References

- Department for Transport (2003) – Traffic Signs Manual Volume 3. Road Markings.

DE013

# Mandatory Cycle Lane



Llywodraeth Cymru  
Welsh Government

Last Revised

September 2014

Do Not Scale Drawing

Drawing Produced By: Arup, 4 Pierhead Street, Capital Waterside, Cardiff, CF10 4QP

Copyright: Welsh Government

# DE014 Advisory Cycle Lane

## Measure and Brief Description

Advisory cycle lanes define an area of the carriageway that is intended for cyclists and are suitable for roads where the speed limit is 30mph or less. Advisory lanes are marked with a broken white line (Diagram 1004) which indicates that other vehicles should not enter unless it is safe to do so. Advisory lanes are less preferable than mandatory lanes, which should be used unless there are particular local circumstances.

## Benefits

- Can be used in circumstances where a carriageway is not wide enough to permit full width mandatory cycle lanes, resulting in occasional motor vehicles entering the cycle lane.
- Can be useful to indicate routes through a large or complex junction.
- Reduces the potential for conflict between motor vehicle and cycles.
- Highlights presence of cyclists.
- Reduced lane width for motor traffic likely to reduce traffic speeds.

## Key Design Features

- Continuity of cycle lane essential.
- Bounded by broken white line 100mm wide (diagram 1004).
- Cycle symbol markings (diagram 1057) should be placed at the start of the lane and after every break, as well as at regular intervals on long uninterrupted lengths.
- TRO not required for advisory cycle lane.
- Waiting and loading restrictions should apply at all times.

## Dimensions

- a - Desirable minimum 2m, Absolute minimum 1.5m.
- Cycle lane entry taper 1:10, exit taper 1:5.

## Other Considerations

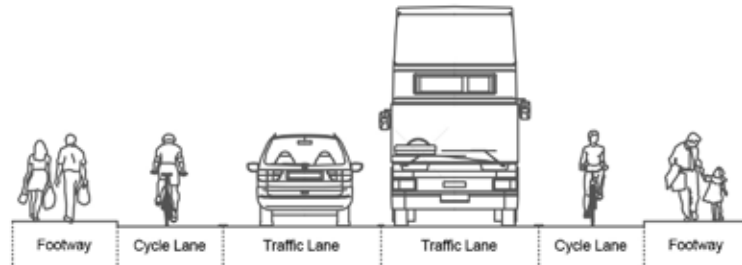
- Where width is constrained, a wider advisory cycle lane may be preferable to a narrow mandatory one.
- There can be benefits in continuing advisory cycle lanes through signalled junctions.
- Additional protection of cycle lanes can be provided using hatched road markings and traffic islands.
- A cyclist riding in the 'secondary' position will fill a 1.5m cycle lane, so if this width cannot be provided a cycle lane is unlikely to be appropriate.
- Inadequate cycle lane widths may increase conflict risk because drivers do not realise that cyclists need to move away from the kerb to avoid surface hazards. A narrow cycle lane may also give motorists (misplaced) confidence to provide less clearance while overtaking than they would in the absence of a cycle lane.
- Greater width should be considered on uphill cycle lanes to allow for additional lateral movement.
- A single uphill cycle lane is preferable to two sub-standard lanes.
- Cycle lanes constrain cyclists to the margin of the carriageway and so cycle-friendly gully gratings are essential.
- Authorities may choose to only place vertical signs to diagram 967 with each diagram 1057 marking where there is a clear need to alter other road users to the presence of the mandatory lane.\*

## Further References

- Department for Transport (2003) – Traffic Signs Manual Volume 3. Road Markings.

DE014

## Advisory Cycle Lane



Llywodraeth Cymru  
Welsh Government

Last Revised

September 2014

Do Not Scale Drawing

Drawing Produced By: Arup, 4 Pierhead Street, Capital Waterside, Cardiff, CF10 4QP

Copyright: Welsh Government

# DE015 Cycle Lane Passing Car Parking/Loading

## Measure and Brief Description

Kerbside vehicle parking or loading can be dangerous for cyclists, especially parking spaces with high vehicle turnover rates, since there is a significant risk to cyclists from vehicle doors being opened. It is therefore highly desirable that cycle lanes pass vehicle parking areas with a dividing strip of sufficient width (buffer strip).

## Benefits

- Prevents cyclists being hit by vehicle doors opening.
- Reduces the risk of cyclists having to swerve into traffic lane to avoid opening doors.
- Encourages good road positioning as taught in cycle training.
- Prevents cyclists getting trapped at the kerbside at the start of a parking bay.

## Key Design Features

- Buffer strip between parking/loading bays and cycle lane.
- Hatched road markings may be used to define the buffer strip.
- Tapers required at approach to and at end of parking/loading bays.

## Dimensions

- a - Desirable minimum 2m, Absolute minimum 1.5m.
- b - Buffer strip along parking/loading bays - desirable minimum 1m, absolute minimum 0.5m min.
- c – width of parking/loading bays:
  - » for cars – min 2m wide.
  - » for vans – min 2.4m wide.
  - » for buses and HGVs min 2.8m wide (preferably 3.2m wide).
- d - general traffic lane should be 2.5m min width, or 3m where there are significant heavy vehicle flows.
- 1:10 approach taper to allow cyclists the opportunity to safely realign themselves before passing parked vehicles.
- 1:5 exit taper to allow cyclists the opportunity to safely realign themselves after passing parked vehicles.

## Other Considerations

- If there is insufficient width for a cycle lane and buffer strip past car parking, consideration should be given to narrowing traffic lanes or removal of centre line, rather than substandard facilities for cyclists.
- It may be possible to remove/relocate parking and introduce mandatory cycle lanes, for example if a street has adequate off street car parking facilities or excess provision.
- Where carriageway widths are narrow and parking cannot be relocated or removed all day, timed mandatory cycle lanes could be considered for peak times.
- A 2.0m wide cycle lane can be reduced locally to 1.5m to allow a 0.5m wide buffer strip to be provided.

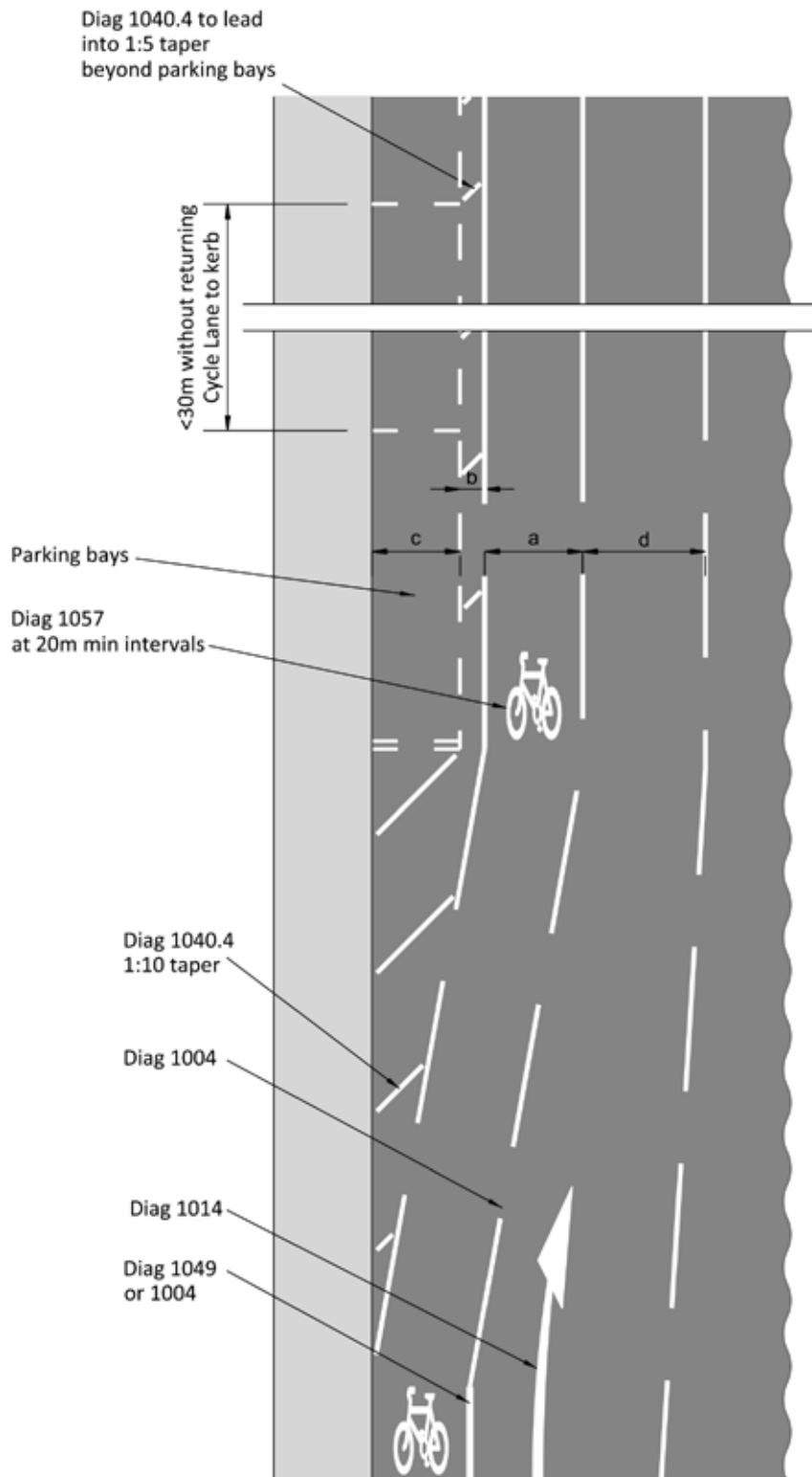
## Further References

- Department for Transport (2003) – Traffic Signs Manual Volume 3. Road Markings.



DE015

## Cycle Lane Passing Car Parking / Loading



Llywodraeth Cymru  
Welsh Government

Last Revised

September 2014

Do Not Scale Drawing

Drawing Produced By: Arup, 4 Pierhead Street, Capital Waterside, Cardiff, CF10 4QP

Copyright: Welsh Government

# DE016 Cycle Lane at Side Road

## Measure and Brief Description

Cycle lanes should continue across side road junctions to ensure continuity and help improve safety. This can be achieved using a stretch of road marking 1010\*, where the white line is broken, since continuous mandatory lanes across side road junctions are not permitted and in preference to advisory cycle lanes to diagram 1004. It is recommended that the cycle lane width be increased at the mouth of side roads to encourage cyclists to position themselves further out from the kerb in order to increase its effectiveness and avoid conflict with vehicles nosing out of junctions.

## Benefits

- improves conspicuity of cyclists at conflict point.
- provides route continuity.

## Key Design Features

- The use of Diagram 1010 markings is recommended in preference to advisory cycle lanes to Diagram 1004 to increase conspicuity\*.
- Cycle symbols (Diagram 1057) may be placed in the cycle lane along the mouth of a junction.
- Coloured road surfacing may also be used in cycle lane to highlight the area of potential conflict.
- Wider cycle lanes across side roads help offer cyclists more space when cars encroach and encourage better road positioning by cyclists.

## Dimensions

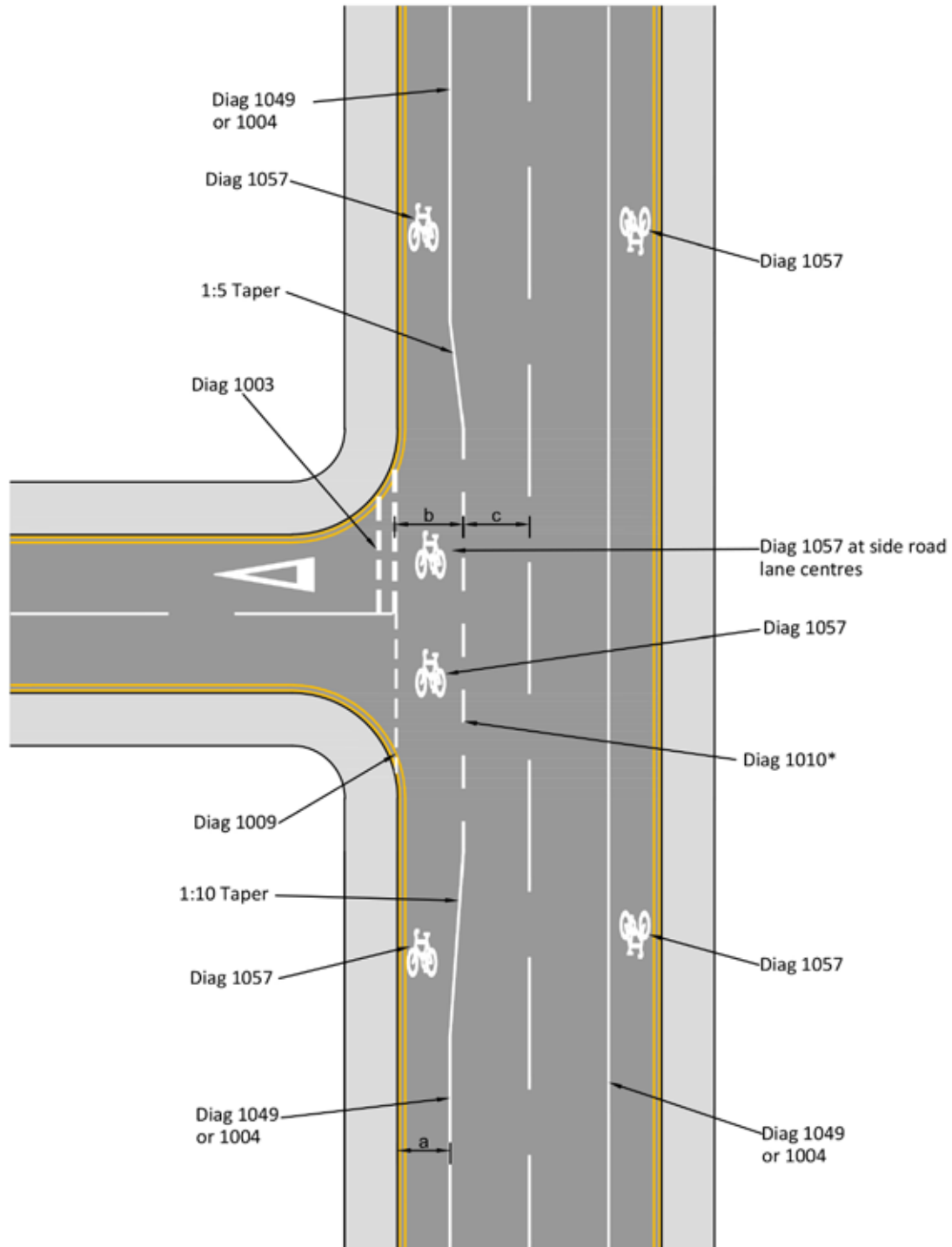
- a – Width on approach - desirable minimum 2m, absolute minimum 1.5m.
- b - Width at side road should be at least 0.5m greater than on approaches.
- c - general traffic lane should be 2.5m min width, or 3m where there are significant heavy vehicle flows.
- Widening at side road introduced with 1:10 entry taper and 1:5 exit taper.

## Other Considerations

- Side road entry treatments (DE39) should also be considered, which provide raised carriageway tables and reduced corner radii at side road junctions. They help reduce turning vehicle speeds, making it safer and more accessible for cyclists passing through the junction and pedestrians crossing the side road.
- Entry to and from side roads should be reviewed to ensure appropriate sightlines and speeds to mitigate risks to cyclists from turning traffic.
- Side-road warning signs to Diagrams 962.1 or 963.1 to warn motorists and pedestrians of the presence of cyclists are generally unnecessary except for situations where contra-flow cycling is permitted.

DE016

# Cycle Lane at Side Roads



Llywodraeth Cymru  
Welsh Government

Last Revised

September 2014

Do Not Scale Drawing

Drawing Produced By: Arup, 4 Pierhead Street, Capital Waterside, Cardiff, CF10 4QP

Copyright: Welsh Government

# DE017 Cycle Lanes with Removal of Centrelines

## Measure and Brief Description

Consideration can be given to the removal of centrelines where carriageway widths do not permit the introduction of cycle lanes of adequate width whilst retaining two general traffic lanes. In addition to increasing the width available for cyclists, the technique also has a speed reducing effect as motor traffic no longer has defined lanes in each direction. Where the need arises for on-coming motor vehicles to pass each other on a narrow carriageway, this is achieved by both drivers momentarily pulling over into their respective near-side advisory cycle lanes, having first checked to see they are clear of cyclists.

## Benefits

- Creates sufficient width for cycle lanes of the appropriate standard.
- Creates a safer and more comfortable environment than sub-standard cycle lanes.
- Achieves speed reduction for motor vehicles.
- Cost-effective, may be facilitated through maintenance works.
- Can be politically more acceptable than other more physical, traffic calming techniques.

## Key Design Features

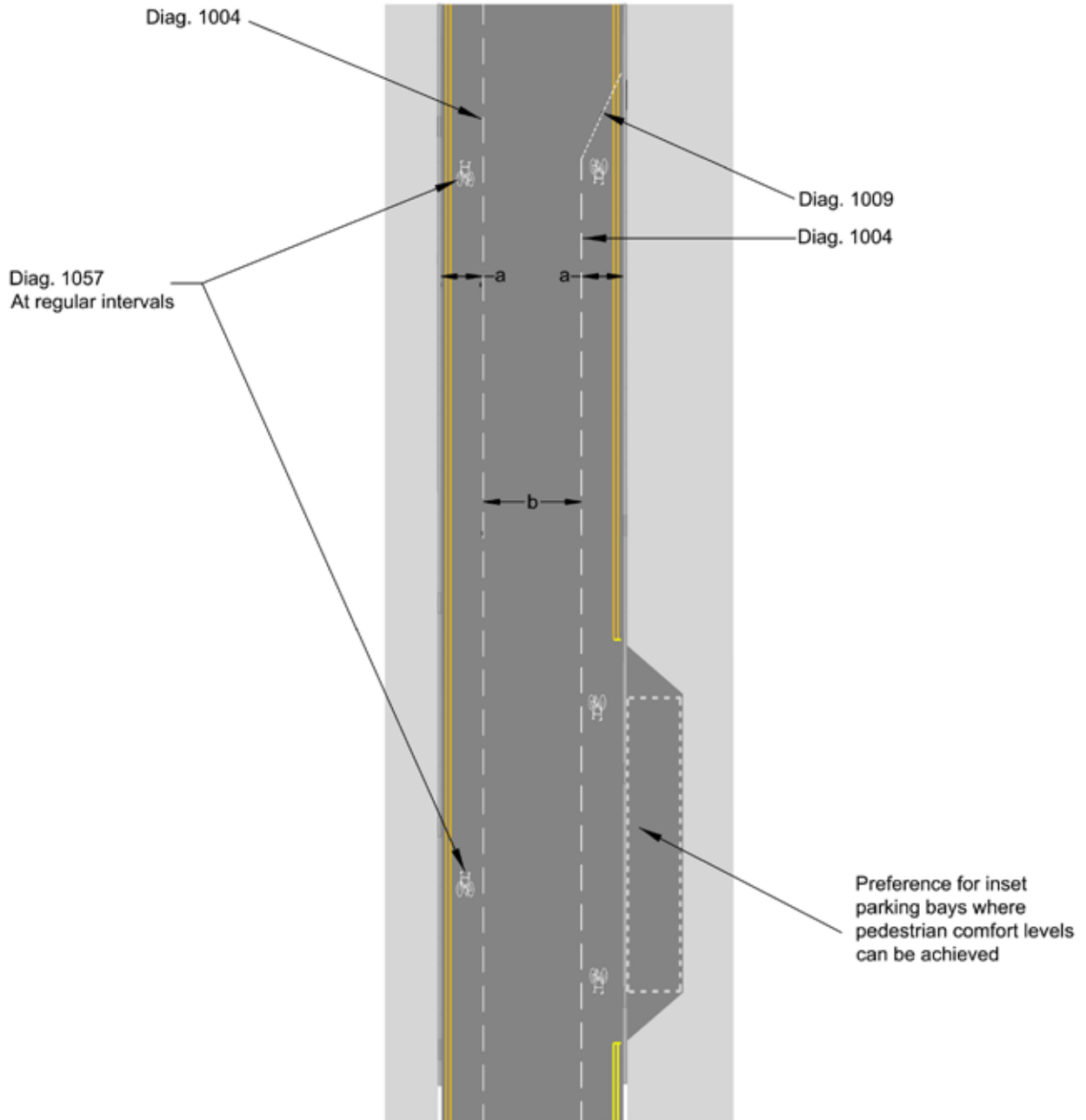
- Not suitable for roads with high traffic and HGV flows.
- A max of 10,000 vehicles AADT is recommended, although schemes have been introduced with traffic volumes of up to 14,000 vehicles AADT.
- Not suitable for roads with speed limits over 30mph.
- Unless only light vehicles are present, advisory cycle lanes should be used so that large vehicles can use the cycle lanes to pass one another.
- Requires adequate forward visibility.

## Dimensions

- a - Desirable minimum 2m, Absolute minimum 1.5m.
- b - central general traffic lane 3m to 5.5m wide, preferably 4.1m – 4.8m.
- Where kerb-side parking is present, provide a buffer strip of 0.5 - 1m, or use inset parking bays.

## Other Considerations

- If the general traffic lanes are wider than 5.5m in total, the additional space should be used to increase the width of cycle lanes.



# DE018 Cycle Lane with Light Segregation

## Measure and Brief Description

The degree of separation provided by a mandatory cycle lane may be reinforced by 'light segregation' from the main carriageway, i.e. intermittent low level physical features such as planters, wands (retroreflective self-righting bollards) or proprietary raised features which may be constructed from rubber, PVC or concrete. The fact that the obstacles are intermittent allows cyclists to manoeuvre between the cycle lane and the carriageway as necessary, avoids any impact on drainage and means that the design is cost effective and flexible.

## Benefits

- Increase cyclist comfort and safety levels, as well as subjective safety.
- Can be used on roads with speed limits of up to 30mph.
- Physical features deter motorists from encroaching into lane.
- Cyclists can manoeuvre in and out of the lane to carry out right turns and for access
- Low installation cost.
- Easily installed to existing cycle lanes.
- Lane widths can be easily adapted to suit future conditions, such as increased usage.
- Can also be used for contra-flow lanes and for two way cycling.
- Avoids the need for drainage works.

## Key Design Features

- Used in combination with a mandatory cycle lane (diagram 1049).
- Advisory cycle lane (diagram 1004) should not be used, as a key design principle is that motor vehicles should not cross light segregation.
- Physical features should be placed on the left hand side of the cycle lane marking so that the marking can clearly be seen by drivers.
- Careful consideration is needed for the design of the physical feature – they need to be conspicuous and robust, but not mimic a road marking or sign.
- Low features should have curved or sloped faces to minimise the hazard for motor vehicles.
- Continuity should be provided at bus stops.

## Dimensions

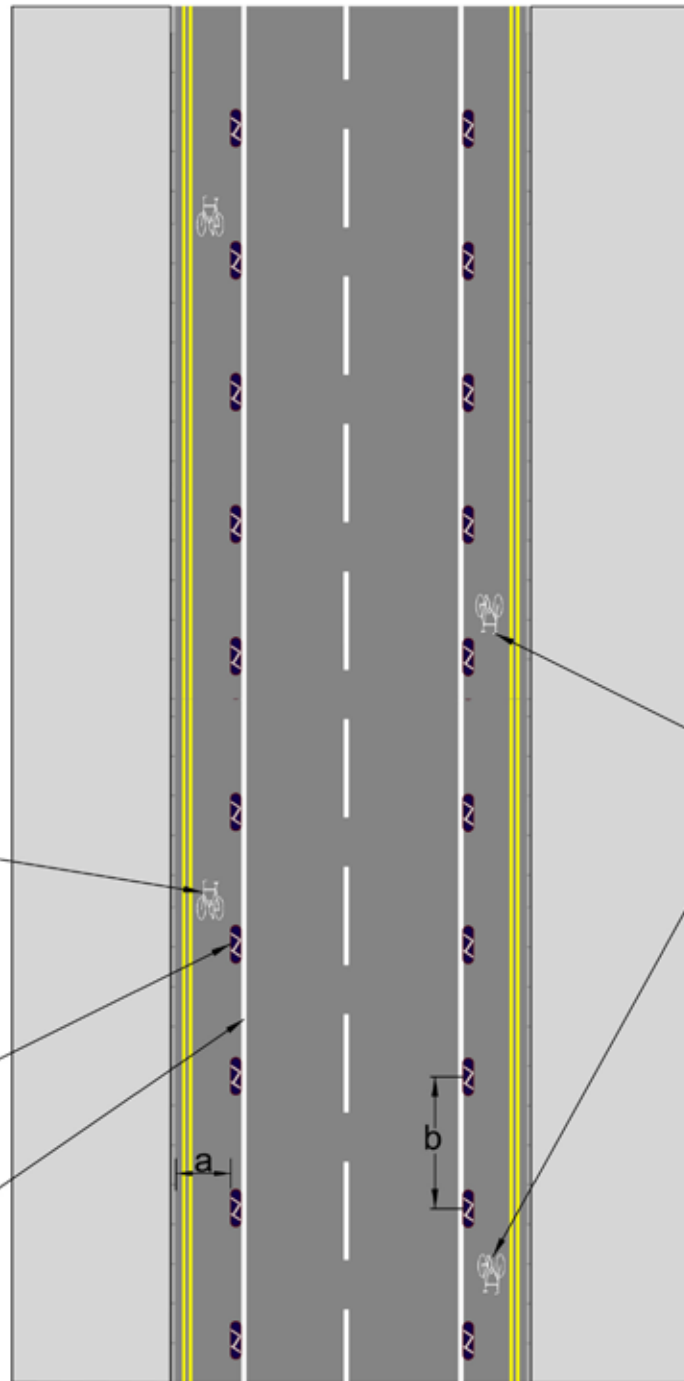
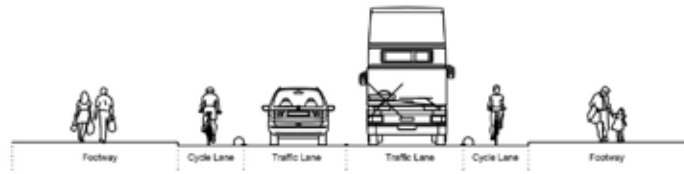
- a - Desirable minimum 2m, Absolute minimum 1.5m.
- Where cycle flows are heavy (over 150 cyclists in the peak hour) and frequent overtaking occurs, widths should be increased to 2.5m.
- b - Segregation features to be spaced at 2.5-10m intervals, or as recommended by the product manufacturer.

## Other Considerations

- If using bollards consideration should be given for illumination or reflective strips.

DE018

# Cycle Lanes With Light Segregation



Diag. 1057

Light Segregation Feature

Diag. 1049

Diag. 1057  
At regular intervals



Llywodraeth Cymru  
Welsh Government

Last Revised

September 2014

Do Not Scale Drawing

Drawing Produced By: Arup, 4 Pierhead Street, Capital Waterside, Cardiff, CF10 4QP

Copyright: Welsh Government



# DE019 Cycle Lane with Light Segregation at Side Road

## Measure and Brief Description

Cycle lanes with light segregation should continue across side road junctions to ensure continuity and help improve cycle safety. This can be achieved using a stretch of road marking 1010\*, where the white line is broken, since continuous mandatory lanes across side road junctions are not permitted and in preference to advisory cycle lanes to diagram 1004.

## Benefits

- improves conspicuity of cyclists at conflict point.
- provides route continuity.

## Key Design Features

- Light segregation feature does not continue across side road.
- The use of Diagram 1010 markings is recommended in preference to advisory cycle lanes to Diagram 1004 to increase conspicuity\*.
- Cycle symbols (Diagram 1057 TSRGD) may be placed in the cycle lane along the mouth of a junction.
- Coloured road surfacing may also be used in cycle lane to highlight the area of potential conflict.

## Dimensions

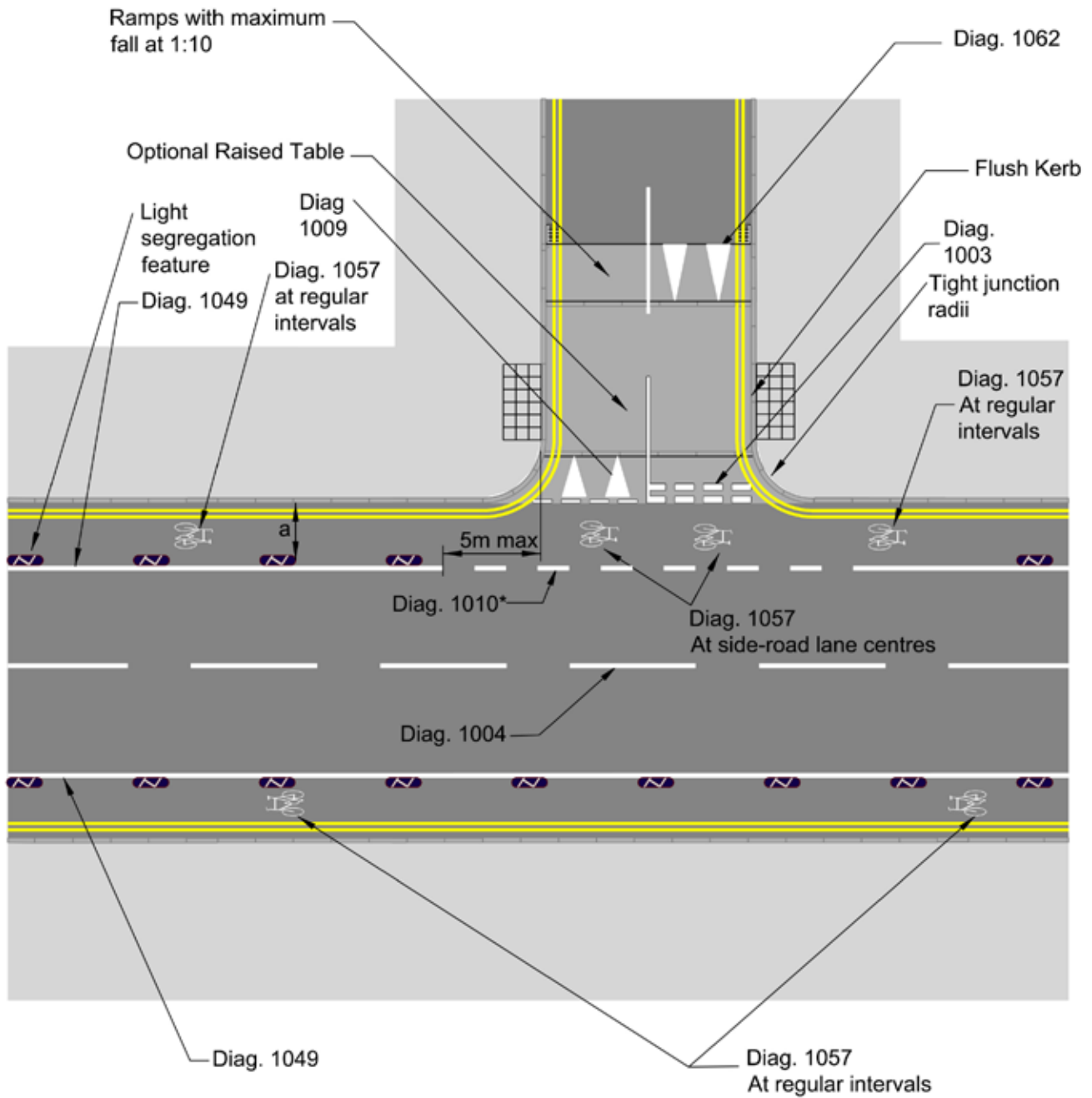
- a – Width on approach - desirable minimum 2m, absolute minimum 1.5m.
- Should be a minimum of 2m wide across side road.
- Segregation features to be spaced at 2.5-10m intervals.
- Segregation to cease no more than 5m from junction, depending on swept path requirements.

## Other Considerations

- Side road entry treatments (DE39) should also be considered, which provide raised carriageway tables and reduced corner radii at side road junctions. They help reduce turning vehicle speeds, making it safer and more accessible for cyclists passing through the junction and pedestrians crossing the side road.
- Entry to and from side roads should be reviewed to ensure appropriate sightlines and speeds to mitigate risks to cyclists from turning traffic.
- Side-road warning signs to Diagrams 962.1 or 963.1 to warn motorists and pedestrians respectively are generally unnecessary except for situations where contra-flow cycling is permitted.
- Widening of the cycle lane at the junction can also be considered.

DE019

# Cycle Lane With Light Segregation at Side Road



Llywodraeth Cymru  
Welsh Government

Last Revised

September 2014

Do Not Scale Drawing

Drawing Produced By: Arup, 4 Pierhead Street, Capital Waterside, Cardiff, CF10 4QP

Copyright: Welsh Government

# DE020 Car Parking/Loading with Light Segregation

## Measure and Brief Description

Car parking/loading may be provided on the carriageway side of cycle lanes with light segregation, preferably with a buffer strip between the edge of the lane and the car parking/loading. Parking/loading should be prohibited in the vicinity of side road junctions and accesses so as to maintain adequate intervisibility.

This detail can also be applied to hybrid cycle tracks.

## Benefits

- Provides cyclists with additional protection from moving traffic.
- Prevents parked cars causing obstruction to cycle lanes/tracks.
- Reduces likelihood and severity of cyclists being hit by vehicle doors opening.
- Prevents cyclists getting trapped at the start of parking bay.

## Key Design Features

- Car parking located on the carriageway side of the cycle lane/track.
- Buffer strip to be provided between the edge of the cycle track and the parking/loading spaces where possible.
- Car parking/loading to be prohibited on the approach to side roads/accesses, so approaching cyclists are clearly visible to traffic coming out of the side road/access.

## Dimensions

- a - Desirable minimum 2m, Absolute minimum 1.5m.
- b - Preferably also provide buffer strip of width 0.5m.
- Segregation features to be spaced at 2.5-10m intervals.

## Other Considerations

- A 2.0m wide cycle track can be reduced locally to 1.5m to allow a 0.5m wide dividing strip to be provided.

DE020 Car parking/Loading with Light Segregation



Light segregation feature (or half height kerb if hybrid track)

Car Parking Bay

Min 1:5 taper

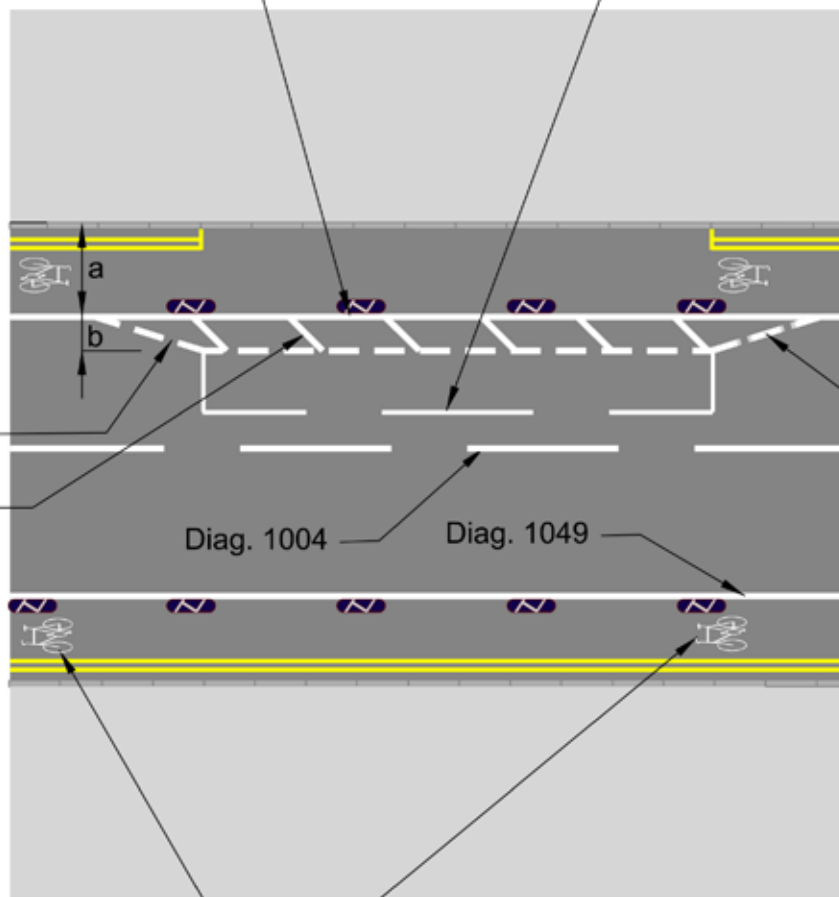
Min 1:5 taper

Diag. 1040.4

Diag. 1004

Diag. 1049

Diag. 1057  
At regular intervals



Llywodraeth Cymru  
Welsh Government

Last Revised

September 2014

Do Not Scale Drawing

Drawing Produced By: Arup, 4 Pierhead Street, Capital Waterside, Cardiff, CF10 4QP

Copyright: Welsh Government

# DE021 Hybrid Cycle Track

## Measure and Brief Description

Hybrid cycle tracks have a surface raised above the carriageway but are below the level of the footway. They keep cyclists close to other traffic but provide more separation from it than a cycle lane or light segregation does. Cyclists can enter and leave the cycle track relatively easily where lowered kerbs or fillets are provided but the presence of a raised kerb edge along most of the length deters encroachment by motor vehicles.

## Benefits

- Increase cyclist comfort and safety levels, as well as subjective safety.
- Can be used on roads with speed limits of up to 30mph.
- Level difference helps deter motorists from straying into cycle lane.
- Priority for cyclists over accesses to properties and side roads is maintained.
- Can reduce the amount of traffic signs and markings compared with mandatory cycle lanes.
- No TRO is required although this would be necessary for parking restrictions.
- Can reduce conflict between cyclists and pedestrians compared with shared use paths.

## Key Design Features

- Hybrid cycle tracks operate one way, in the same direction as motor traffic flow.
- Space can be taken from footway or preferably carriageway to create the track.
- Lowered to merge with the carriageway at junctions or other areas where cyclists need to access the general traffic lanes.
- Continuity should be provided at bus stops.
- Hybrid tracks at side roads retain priority for cyclists.

## Dimensions

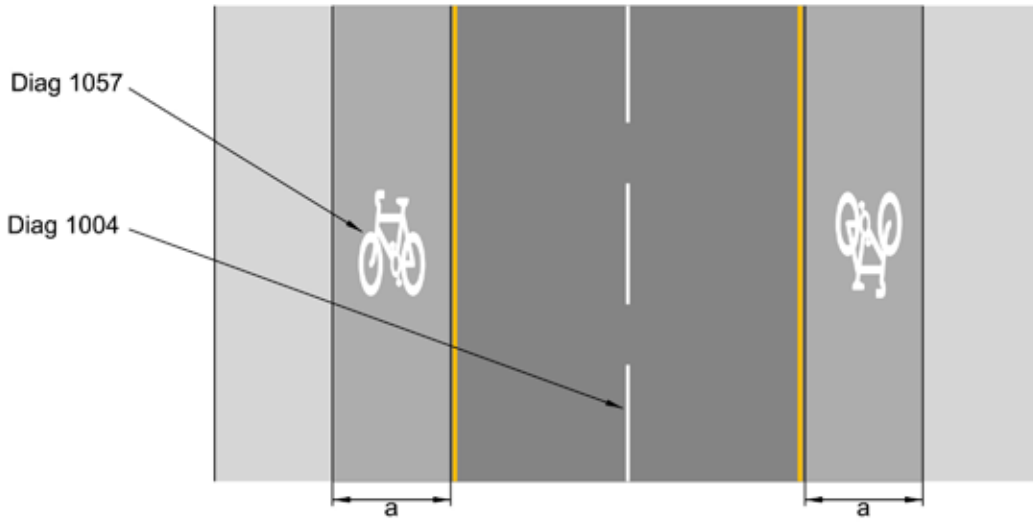
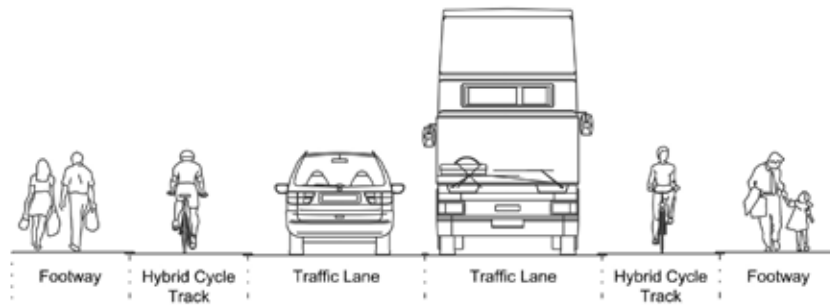
- a - Desirable minimum 2m, Absolute minimum 1.5m.
- Where cycle flows are heavy (over 150 cyclists in the peak hour) and frequent overtaking occurs, widths should be increased to 2.5m.
- Minimum kerb upstands should generally be 50mm on the carriageway side, and 25mm on the footway side.
- Lamp columns, sign posts, etc should be placed 0.5m from any hybrid cycle lane.

## Other Considerations

- New drainage facilities will need to be introduced into the narrowed carriageway while existing grates will need to be raised to cycle track level. Cycle friendly drainage grates should be used for both.
- Can be used as part of centreline removal projects.
- There is no particular requirement to sign hybrid tracks (or use coloured surfacing). In many cases, the kerb upstand itself will suffice to deter motor vehicles from entering. However, the use of a mandatory lane placed on the carriageway side of the kerb could be considered if encroachment by motor vehicles (including parking) becomes a problem.

DE021

# Hybrid Cycle Track



Llywodraeth Cymru  
Welsh Government

Last Revised

September 2014

Do Not Scale Drawing

Drawing Produced By: Arup, 4 Pierhead Street, Capital Waterside, Cardiff, CF10 4QP

Copyright: Welsh Government

# DE022 Hybrid Cycle Track at Side Road

## Measure and Brief Description

As hybrid tracks are still considered part of the carriageway, and normally operate one-way in the same direction as general traffic, they should cross side roads in the same position as a cycle lane, ensuring route continuity. One-way hybrid tracks should normally retain priority over side roads; this can be achieved by:

- Continuing the hybrid track through the junction with a flush kerb;
- Stopping the hybrid track within 5m of the junction on either side with a raised crossing for turning traffic and tight corner radii at the side road; or
- By the hybrid track becoming a cycle lane 20m -30m in advance of the side road (in which case refer to DE016).

## Benefits

- helps the conspicuity of cyclists at conflict point.
- helps with route continuity.

## Key Design Features

- Side road give-way markings should be set back from the hybrid track.
- Cycle symbols (Diagram 1057) may be placed in the cycle track/lane across the mouth of a junction.
- Coloured road surfacing may also be used in cycle track/lane to highlight the area of potential conflict.
- Care needs to be taken where hybrid tracks pass private accesses, to ensure drivers emerging from the access can see cyclists. Cyclists should not normally be required to give way to vehicles using accesses.

## Dimensions

- a – Width on approach - desirable minimum 2m, absolute minimum 1.5m.

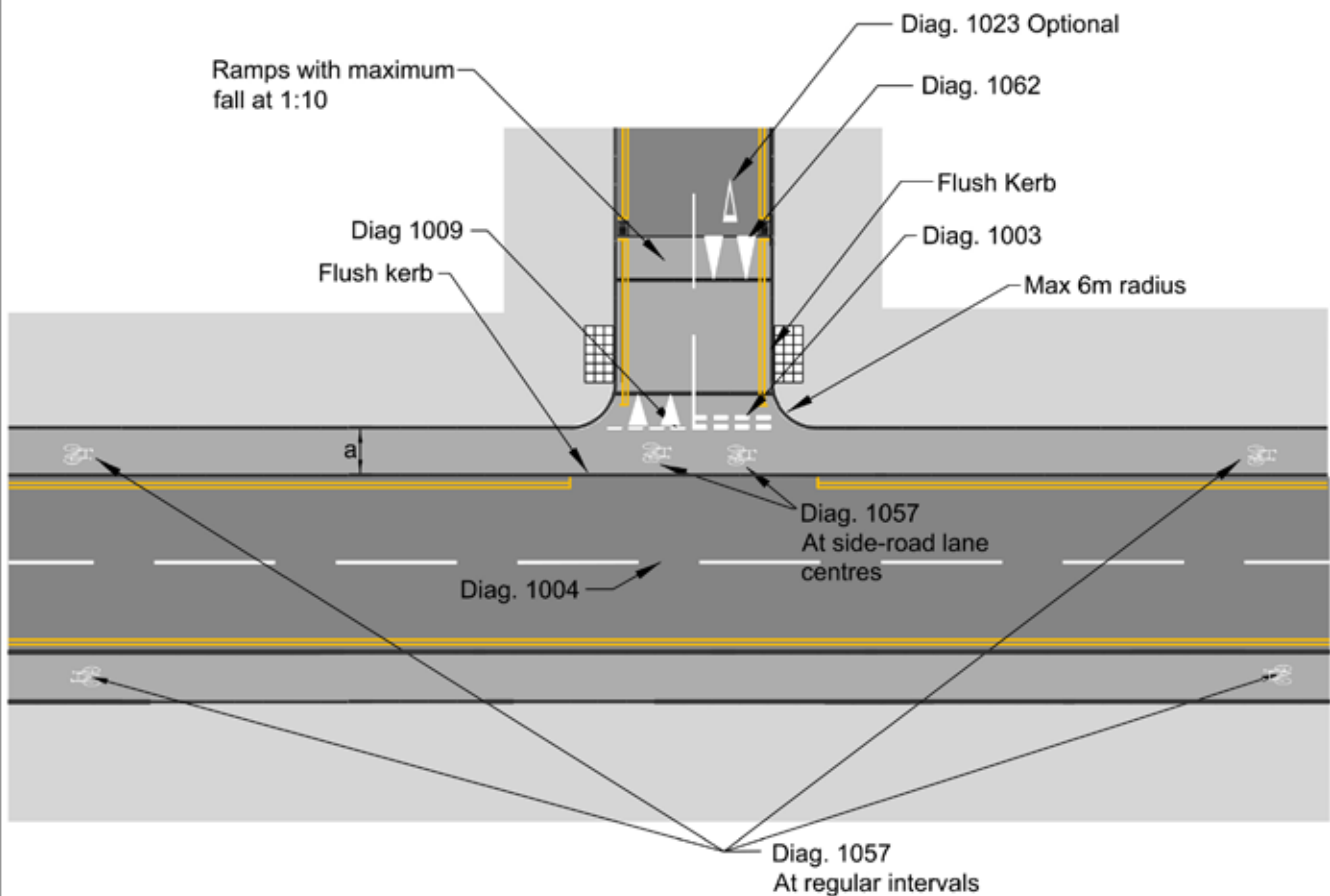
## Other Considerations

- Side road entry treatments (DE39) should also be considered, which provide raised carriageway tables and reduced corner radii at side road junctions. They help reduce turning vehicle speeds, making it safer and more accessible for cyclists passing through the junction and pedestrians crossing the side road.
- Entry to and from side roads should be reviewed to ensure appropriate sightlines and speeds to mitigate risks to cyclists from turning traffic.
- Side-road warning signs to Diagrams 962.1 or 963.1 to warn motorists and pedestrians respectively are generally unnecessary except for situations where contra-flow cycling is permitted.
- Widening of the cycle lane at the junction can also be considered.



DE022

## Hybrid Cycle Track at Side Roads



Llywodraeth Cymru  
Welsh Government

Last Revised

September 2014

Do Not Scale Drawing

Drawing Produced By: Arup, 4 Pierhead Street, Capital Waterside, Cardiff, CF10 4QP

Copyright: Welsh Government

# DE023 Cycle Track Alongside Road, Separated From Pedestrians

## Measure and Brief Description

Where traffic volumes and/or speeds are too high for cycle lanes, light segregation or hybrid tracks, physical separation from motor traffic may be appropriate to provide cyclists with safe and comfortable space, through the provision of segregated cycle tracks. Segregated cycle tracks should be of adequate width, comfortable, continuous and link into surrounding cycling routes. Preferably they will be provided through reallocation of road space from the carriageway; in most urban locations the conversion of footways to segregated shared use should be the last resort.

Physical segregation from pedestrians is generally preferred provided widths are adequate and this can be achieved through a level difference or verge. Barriers between cycle tracks and footways are not desirable since they limit the effective width of the paths and are a particular hazard to cyclists. Segregation using only simple white lines (Diag 1049) (which are not detectable by blind users) or a raised white line delineator (Diag 1049.1), is an option but it is rarely respected by pedestrians (who have the legal right to use the cycle track) in practice, unless cycle flows are high or there is generous width, and should therefore be avoided.

## Benefits

- Provides routes which are free from conflict with motor traffic.
- Segregated paths allow each group to move at their own desired pace and improve comfort and subjective safety.

## Key Design Features

- The cycle track should normally be located between carriageway and footway.
- Footways and cycle tracks should be continuous across private accesses.
- Pedestrians require regular crossing points with flush kerbs between the cycle track and the carriageway; tactile paving should be provided.
- Cycle tracks should not deflect more than 45° and changes in height should be avoided.
- Machine-laid black bituminous surfacing should be used as it will make cycle journeys safer, more comfortable and helps distinguish cycle tracks from adjacent footways surfaced by pavements or slabs.
- Lamp columns and other street furniture should not be placed in cycle tracks.
- Centre lines should be marked on two-way cycle tracks.

## Dimensions

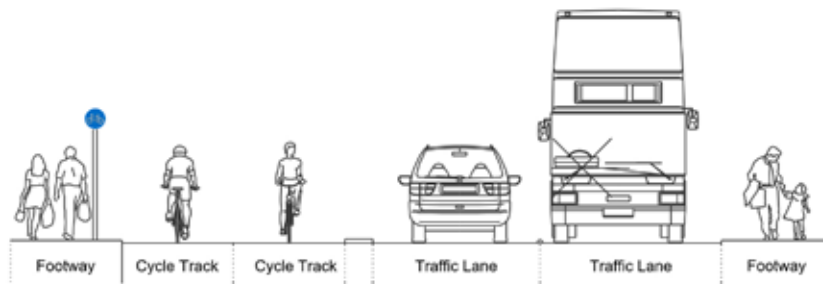
- a - Cycle track width should be sufficient to accommodate the forecast level of use with a minimum of:
  - » Absolute minimum 2.5m, where the peak hour cycle flow is less than 50/hr;
  - » Desirable minimum 3m, where it is 50-150/hr, 4m for cycle flows over 150/hr.
- Cycle tracks should include additional width where they are bounded by vertical features. Additional width required is:
  - » Kerb up to 150mm high: add 200mm.
  - » Vertical feature 150-600mm high: add 250mm.
  - » Vertical feature above 600mm high: add 500mm.
- b - In addition to the path width above, a margin strip separating the cycle track from the carriageway is recommended:
  - » Desirable minimum 0.5m with speed limits of 30mph
  - » Desirable minimum 1.5m with speeds limits of 40mph or above.
- c - The width of the footway should reflect the level and type of use, based on level of service, Desirable minimum 2m width, increasing to 3.5m width where there is frequent use by groups. 1.5m may be acceptable over short lengths – see DE001.
- Verges separating pedestrian and cycle routes should be a minimum of 1m wide.

## Other Considerations

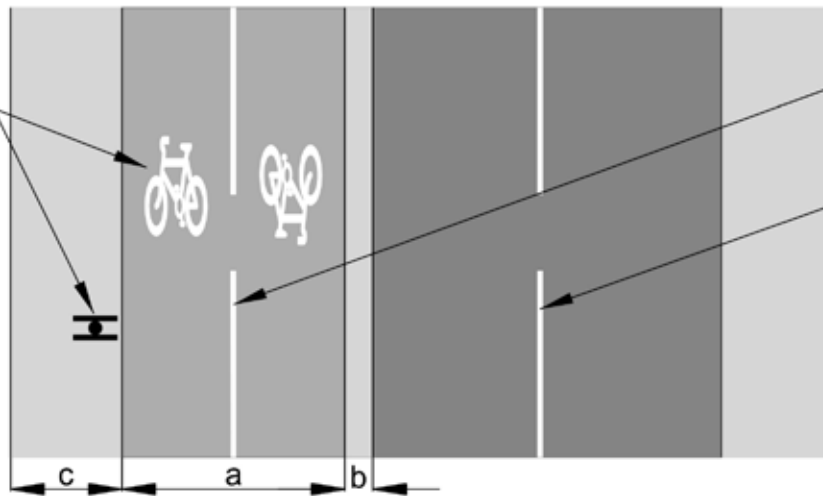
- Generally cycle tracks alongside the carriageway will either be two-way, usually on one side of the road, or one-way on both sides of the road. Historically most cycle tracks in the UK have been built as two-way, but this can present safety problems at junctions.
- Care needs to be taken where a cycle track passes private accesses, to ensure drivers emerging from the access can see cyclists.
- Two way tracks are therefore best suited to routes that have few side road junctions and accesses.
- Use of white lining to provide a buffer between the cycle track and carriageway is not recommended in unlit areas, as this could be misinterpreted as marking the edge of carriageway by passing motorists, who are then at risk of striking the kerb and losing control.
- Upright signs to indicate cycle track should preferably be located in the verge or footway.

DE023

# Cycle Track Alongside Road, Separated From Pedestrians



Diag 955 mounted back to back and Diag 1057 to be located at start of cycle track, after each break and at intervals along the route



Diag 1004 (to be omitted if cycle track < 3.0m)

Diag 1004



Llywodraeth Cymru  
Welsh Government

Last Revised

September 2014

Do Not Scale Drawing

Drawing Produced By: Arup, 4 Pierhead Street, Capital Waterside, Cardiff, CF10 4QP

Copyright: Welsh Government

# DE024 Cycle Track Alongside Road, Shared With Pedestrians

## Measure and Brief Description

Where traffic volumes and/or speeds are too high for cycle lanes, light segregation or hybrid tracks, physical separation from motor traffic may be appropriate to provide cyclists with safe and comfortable space. Where a cycle track will be shared with pedestrians, sufficient width must be provided for the two user groups to interact safely and in comfort. It is essential that developing the design of an unsegregated shared use track includes early consultation with relevant interested parties such as those representing people with disabilities, pedestrians and cyclists. Preferably they will be provided through reallocation of road space from the carriageway; in most urban locations the conversion of footways to unsegregated shared use should be the last resort.

## Key Design Features

- Shared cycle tracks should be continuous across private accesses.
- Pedestrians require regular crossing points with flush kerbs; tactile paving should be provided.
- Cycle tracks should not deflect more than 45° and changes in height should be avoided.
- Machine-laid bituminous surfacing should be used as it will make cycle journeys safer, more comfortable and helps distinguish shared cycle tracks from nearby footways surfaced by pavements or slabs.
- Lamp columns and other street furniture should not be placed in cycle tracks.

## Dimensions

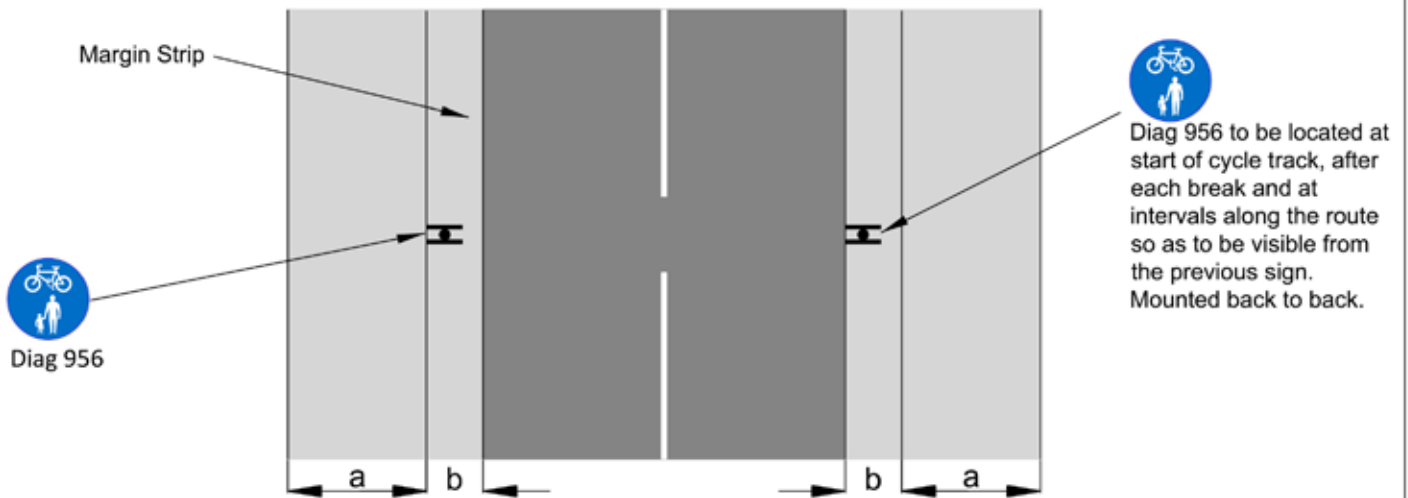
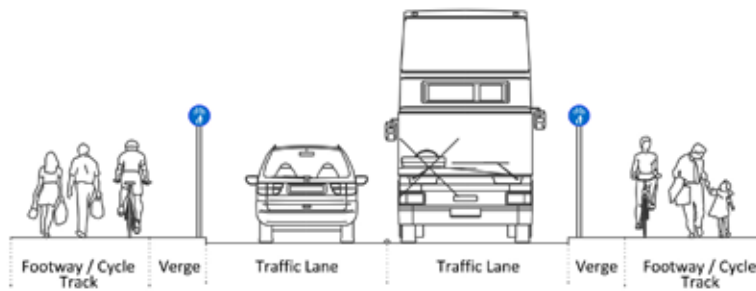
- a - width should reflect the level and type of use forecast with a minimum of 3m width on primary cycle routes, or 2.5m on less busy secondary routes. On particularly heavily trafficked routes it should be increased to 4m.
- Unsegregated cycle tracks should include additional width where they are bounded by vertical features. Additional width required is:
  - Kerb up to 150mm high: add 200mm;
  - Vertical feature 150-600mm high: add 250mm;
  - Vertical feature above 600mm high: add 500mm.
- b - In addition to the path width above, a margin strip separating the cycle track from the carriageway is recommended:
  - Desirable minimum 0.5m with speed limits of 30mph;
  - Desirable minimum 1.5m with speed limits of 40mph or above.

## Other Considerations

- Generally cycle tracks alongside the carriageway will either be two-way, usually on one side of the road, or one-way on both sides of the road. Historically most cycle tracks in the UK have been built as two-way, but this can present safety problems at junctions.
- Care needs to be taken where a cycle track passes private accesses, to ensure drivers emerging from the access can see cyclists.
- Two way tracks are therefore best suited to routes that have few side road junctions and accesses.
- Use of white lining to provide a buffer is not recommended in unlit areas, as this could be misinterpreted as marking the edge of carriageway by passing motorists, who are then at risk of striking the kerb and losing control.
- Upright signs to indicate cycle track should preferably be located in any verge between the cycle track and the carriageway.

DE024

# Cycle Track Alongside Road, Shared With Pedestrians



Llywodraeth Cymru  
Welsh Government

Last Revised

September 2014

Do Not Scale Drawing

Drawing Produced By: Arup, 4 Pierhead Street, Capital Waterside, Cardiff, CF10 4QP

Copyright: Welsh Government

# DE025 Cycle Track at Side Road with Cycle Priority

## Measure and Brief Description

Uncontrolled cycle track crossings at side roads should, wherever safe and practicable, give priority to cyclists crossing the side road. Such crossings will allow cyclists to continue without loss of momentum and present a strong promotional message about how non-motorised users are valued along a corridor. Factors to be considered when determining who has priority include: location, motor vehicle speed and volume, visibility, number of pedestrian and cycle movements and collision records.

## Benefits

- Improved continuity and reduced effort for cyclists.
- Raised status for pedestrian and cyclists.
- Reduced vehicle speeds on side roads entering junction.

## Key Design Features

- Side roads and accesses where vehicle speeds are less than 30mph and volume is less than 2,000 vpd will normally be suitable for cycle priority crossings.
- When cycle tracks are two way, drivers waiting to turn right into a side road may not anticipate cycles approaching from behind. Similarly drivers emerging from the side road may not anticipate cycles approaching from the left. One way cycle tracks which operate in the same direction as general traffic are therefore preferred.
- Cycle priority crossings should be located on a raised table.
- The corner radii and carriageway width of the side road should be minimised.
- Cycle track should not turn through more than 45 degrees on approaches.
- There needs to be good levels of inter-visibility between pedestrians, cyclists and motorists.

## Dimensions

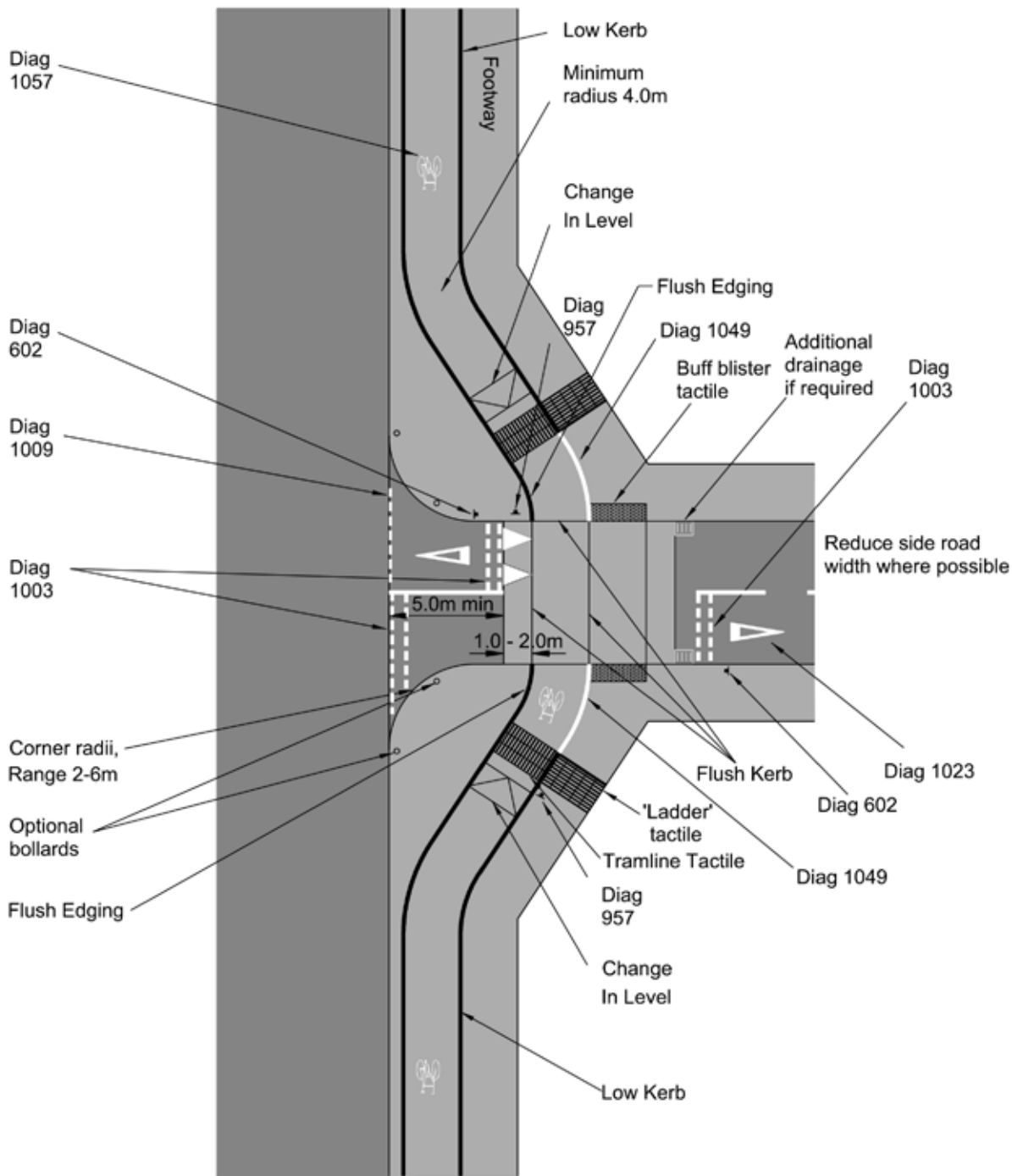
- Cycle priority crossings should normally be 'bent out', i.e. set back 5m from the junction channel line to enable a car to stop clear of the main carriageway. However, there are examples of schemes where the cycle track has been built closer to the junction which have operated satisfactorily.
- This option can be considered where there is only light traffic using the side road and speeds on the main road are no greater than 30mph.

## Other Considerations

- Consider highlighting the crossing with coloured surfacing.
- Cycle track crossings can be difficult places for younger or inexperienced cyclists to negotiate, as they need to ensure that they are aware of vehicles on both the main carriageway and the side roads and judge speeds and turning movements. Simple design and clear signing is therefore important.

DE025

# Cycle Track at Side Road with Cycle Priority



Llywodraeth Cymru  
Welsh Government

Last Revised

September 2014

Do Not Scale Drawing

Drawing Produced By: Arup, 4 Pierhead Street, Capital Waterside, Cardiff, CF10 4QP

Copyright: Welsh Government



# DE026 Cycle Track at Side Road, Cyclists Give Way

## Measure and Brief Description

Although they are preferred, priority crossings for cyclists (DE025) will not be appropriate in all locations, and where the cyclist is expected to give way clear road markings will be necessary, together with measures to reduce the speed of vehicles using the junction. Restricting traffic movements into the side road may enable cycle priority to be considered without a set back from the carriageway edge. Factors to be considered when determining who has priority include: location, motor vehicle speed and volume, visibility, number of pedestrian and cycle movements and collision records.

## Benefits

- Less land required than 'bent out' priority crossings (DE025)
- Retains line of cycle track

## Key Design Features

- Side roads and accesses where vehicle speeds are less than 30mph and volume is less than 2,000 vpd will normally be suitable for cycle priority crossings.
- When cycle tracks are two way, drivers waiting to turn right into a side road may not anticipate cycles approaching from behind. Similarly drivers emerging from the side road may not anticipate cycles approaching from the left. One way cycle tracks which operate in the same direction as general traffic are therefore preferred.
- Cycle priority crossings should be located on a raised table.
- The corner radii and carriageway width of the side road should be minimised.
- Cycle track should not turn through more than 45 degrees on approaches.
- There needs to be good levels of inter-visibility between pedestrians, cyclists and motorists.

## Dimensions

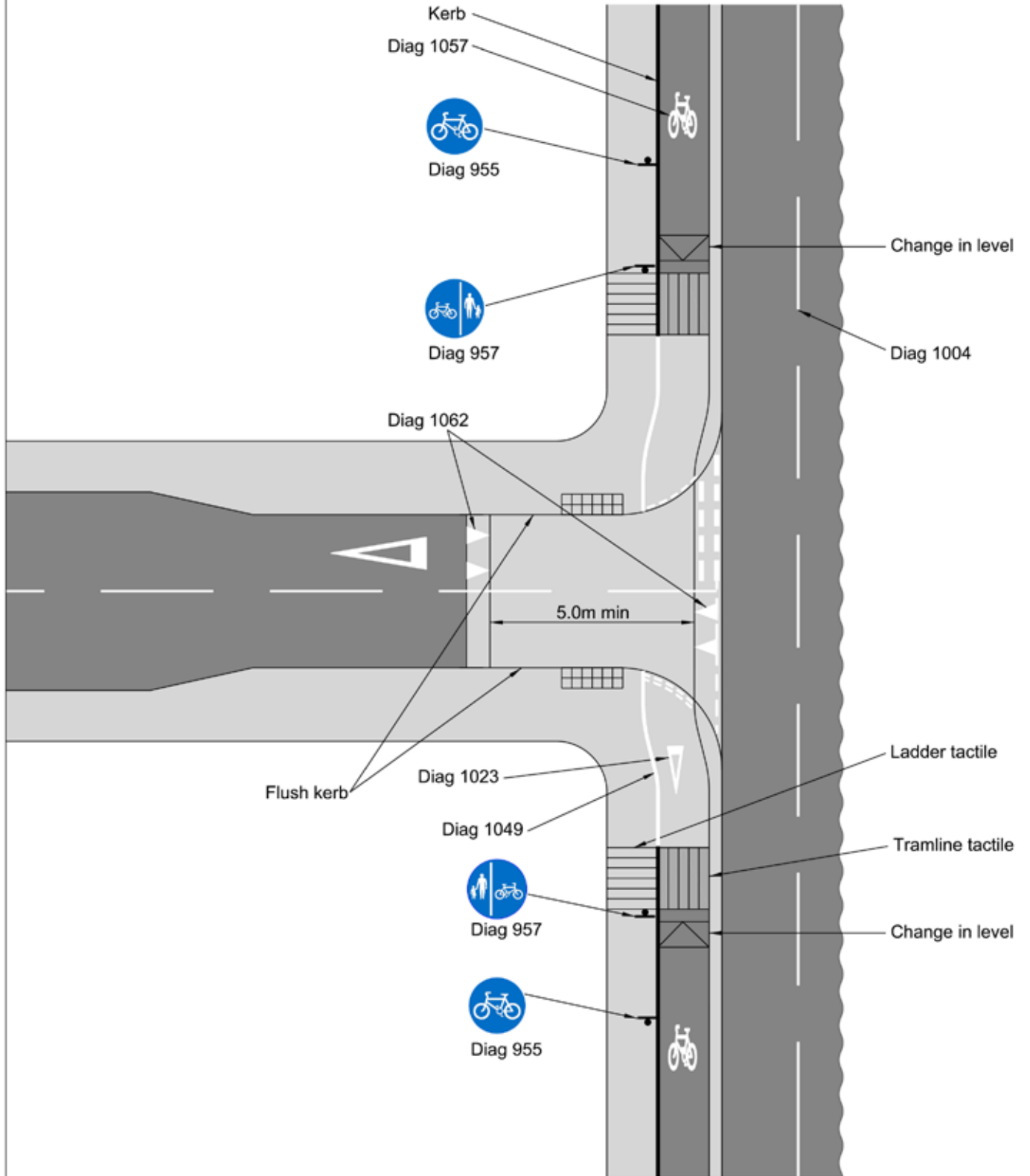
- Side road crossings where cyclists give way do not need to be set back from the main road carriageway any further than the cycle track itself.

## Other Considerations

- Cyclists have to look through a wide angle to see approaching vehicles.
- Consider highlighting the crossing with coloured surfacing.
- Cycle track crossings can be difficult places for younger or inexperienced cyclists to negotiate, as they need to ensure that they are aware of vehicles on both the main carriageway and the side roads and judge speeds and turning movements. Simple design and clear signing is therefore important.

DE026

# Cycle Track at Side Road, Cyclists Give Way



Llywodraeth Cymru  
Welsh Government

Last Revised

September 2014

Do Not Scale Drawing

Drawing Produced By: Arup, 4 Pierhead Street, Capital Waterside, Cardiff, CF10 4QP

Copyright: Welsh Government

# DE027 Two-Way Cycle Track in Centre of Carriageway

## Measure and Brief Description

Two-way tracks for cyclists in the centre of the carriageway can offer a good level of service. Cyclists are in a highly visible location which has no conflict with parked vehicles, bus stops or loading, or vehicles turning into and out of left in/left out side road junctions or accesses. The key issue to be resolved is the provision of access to the track, which can be via priority and signal controlled crossings, or signal controlled junctions with cycle stages. Where motor traffic volumes are not high mini or compact roundabouts are also an option, since cyclists will be arriving into and leaving from the junction in a dominant position.

## Benefits

- No conflict with kerbside activity.
- High profile facility.

## Key Design Features

- Two way cycle track should be protected with kerb upstands or with light segregation.
- Tracks can be provided in wide central reservations, including on higher speed roads.
- Similarly, one-way light-segregated lanes, hybrid tracks or tracks can be provided adjacent to the central reservation on dual carriageways.
- Cycle priority to be maintained across any lightly-trafficked central reservation gaps.
- U-turns at central reservation gaps should be banned.

## Dimensions

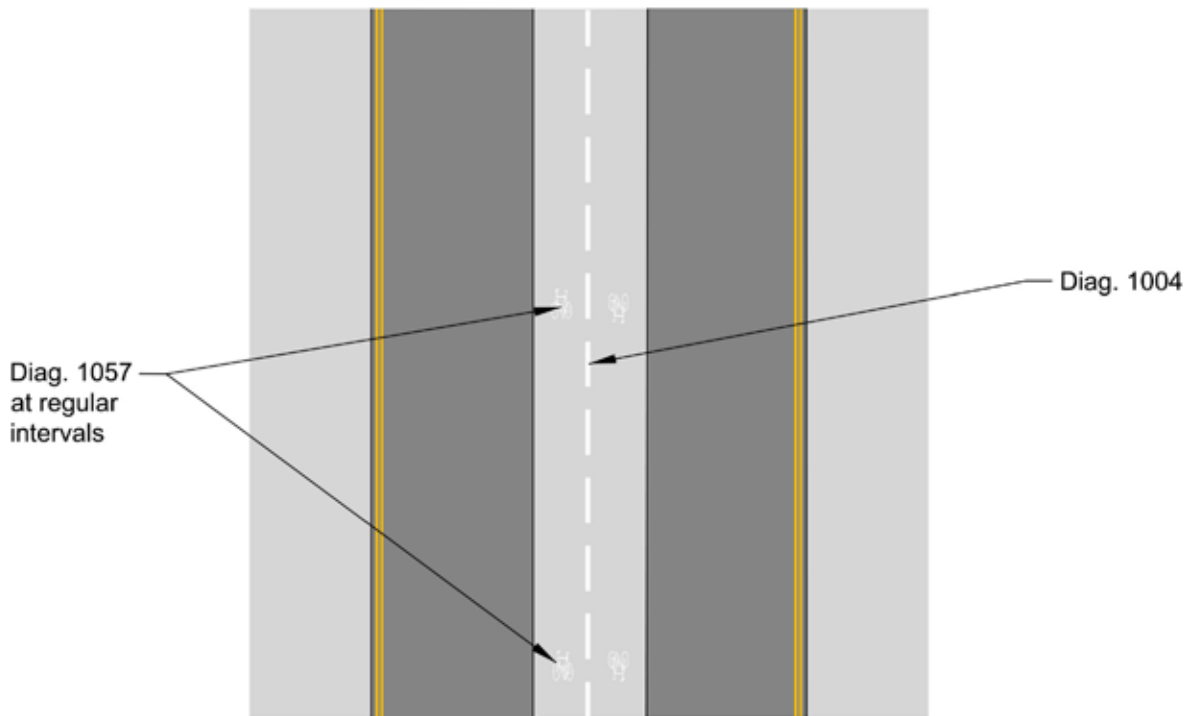
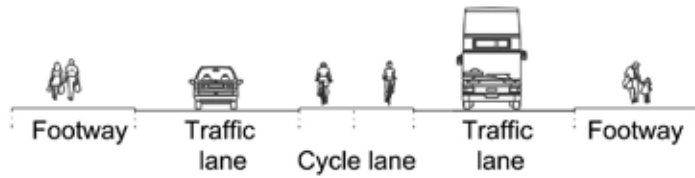
- Cycle track width should be sufficient to accommodate the forecast level of cycle use with a minimum of:
  - » Absolute minimum 2.5m, where the peak hour cycle flow is less than 50/hr;
  - » Desirable minimum 3m, where the peak hour cycle flow is 50-150/hr, 4m for peak hour cycle flows over 150/hr.

## Other Considerations

- Provision should be made for pedestrians crossing movements at regular intervals.

DE027

# 2 Way Cycle Tracks in Centre of Carriageway



Llywodraeth Cymru  
Welsh Government

Last Revised

September 2014

Do Not Scale Drawing

Drawing Produced By: Arup, 4 Pierhead Street, Capital Waterside, Cardiff, CF10 4QP

Copyright: Welsh Government

# DE028 Bus Stop: Cycle Lane Bypass

## Measure and Brief Description

Cyclists should be enabled to pass stationary buses so that they can maintain momentum and minimise delay. The Traffic Signs Manual advises that where cycle lanes in the usual position next to the kerb encounter bus stops they should be terminated and begin again after the bus cage. This requires cyclists to move out into general traffic, which does not meet their needs.

The provision of a cycle lane bypass around the bus stop provides a preferable solution. This design is best suited to urban areas where traffic speeds are below 30mph, and where bus frequency is high (more than 6 buses per hour) or bus stops are occupied for 15 min per hour or more.

## Benefits

- Maintains route continuity.
- Cycle lane around the bus stop cage reduces the risk of collision with traffic when a cyclist overtakes a stationary bus.
- It provides space between an overtaking cyclist and stationary bus.
- Best suited at bus stops with high passenger numbers and high bus frequency.

## Key Design Features

- Marked route for cyclists bypasses bus cage.
- Sufficient width for cycle lane and buffer strip past bus cage.
- Approach taper to be no more than 1 in 10.

## Dimensions

- a - Desirable minimum 2m, Absolute minimum 1.5m.
- b - buffer strip - Desirable minimum 1m, Absolute minimum 0.5m.
- c - bus cage width Desirable minimum 3m, Absolute minimum 2.7m.
- d - general traffic lane width 3m Desirable minimum.

## Other Considerations

- Also compatible with one-way light segregated cycle lanes and hybrid tracks, which become cycle lanes past the bus stop
- Variants of this design can be considered where buses are provided with full or half width bus laybys.



After Bus cage, Cycle lane to return back to kerb edge at 1:5 taper

Bus Stop  
Diag 1025.1  
Diag 1057  
at regular intervals

1:10 taper

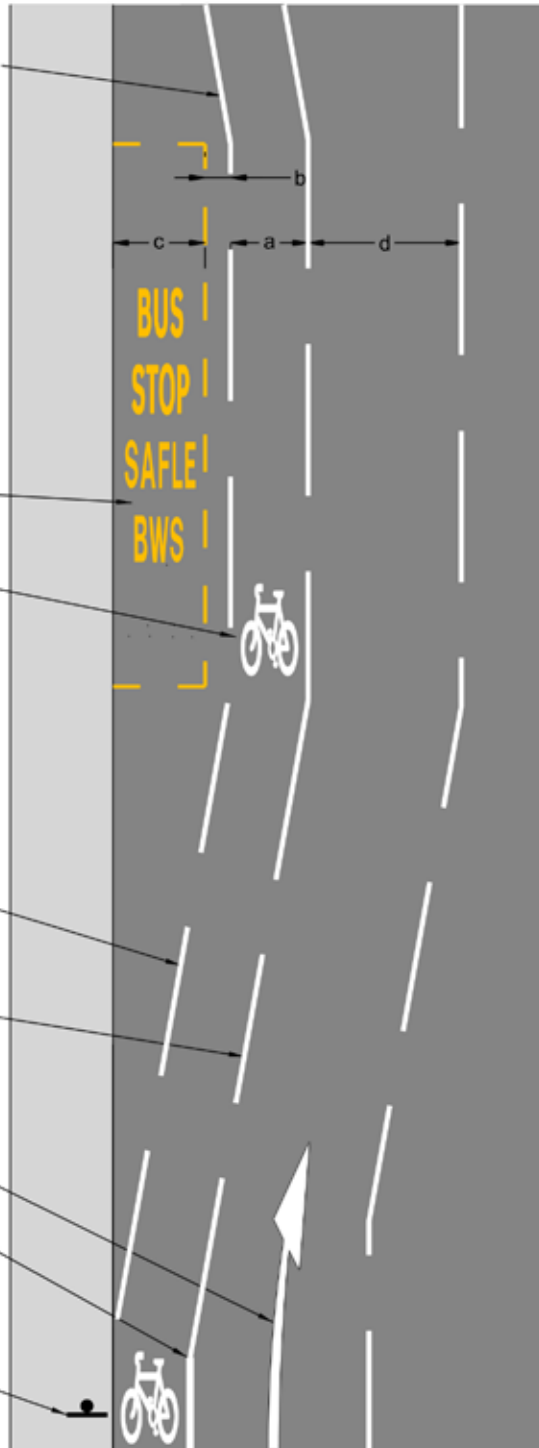
Diag 1004

Diag 1014

Diag 1049 or  
Diag 1004



Diag 967



# DE029 Bus Stop: Island Bus Stop

## Measure and Brief Description

Cyclists should be enabled to pass stationary buses so that they can maintain momentum and minimise delay. The Traffic Signs Manual advises that where cycle lanes in the usual position next to the kerb encounter bus stops they should be terminated and begin again after the bus cage. This requires cyclists to move out into general traffic, which does not meet their needs.

The safest and most comfortable way to enable cyclists to pass stationary buses is to provide a cycle track past the bus stop on the footway side. Passengers will board and alight from buses from the kerbed island between the cycle track and the carriageway. The suitability of this is dependent on the available space, bus frequency and passenger volume and the number of pedestrians using the footway.

## Benefits

- Maintains route continuity for cyclists.
- Eliminates the risk of conflict with buses.
- More comfortable and attractive, especially for less confident cyclists.

## Key Design Features

- Sufficient widths should be provided for pedestrians walking past the stop and on the island to accommodate passengers waiting for and alighting from buses.
- It may be appropriate to raise the bypass to footway level along part or all of its length, which slows cyclists down providing more reaction time for pedestrians, and increasing convenience for disabled bus users.
- Sinusoidal humps preferred on ramps.
- Minimum bypass entry / exit taper 1:10
- Tactile paving to be provided at crossing point(s) of cycle track.

## Dimensions

- a - Desirable minimum 2m, Absolute minimum 1.5m.
- b – Island width Desirable minimum 2m, Absolute minimum 1m.

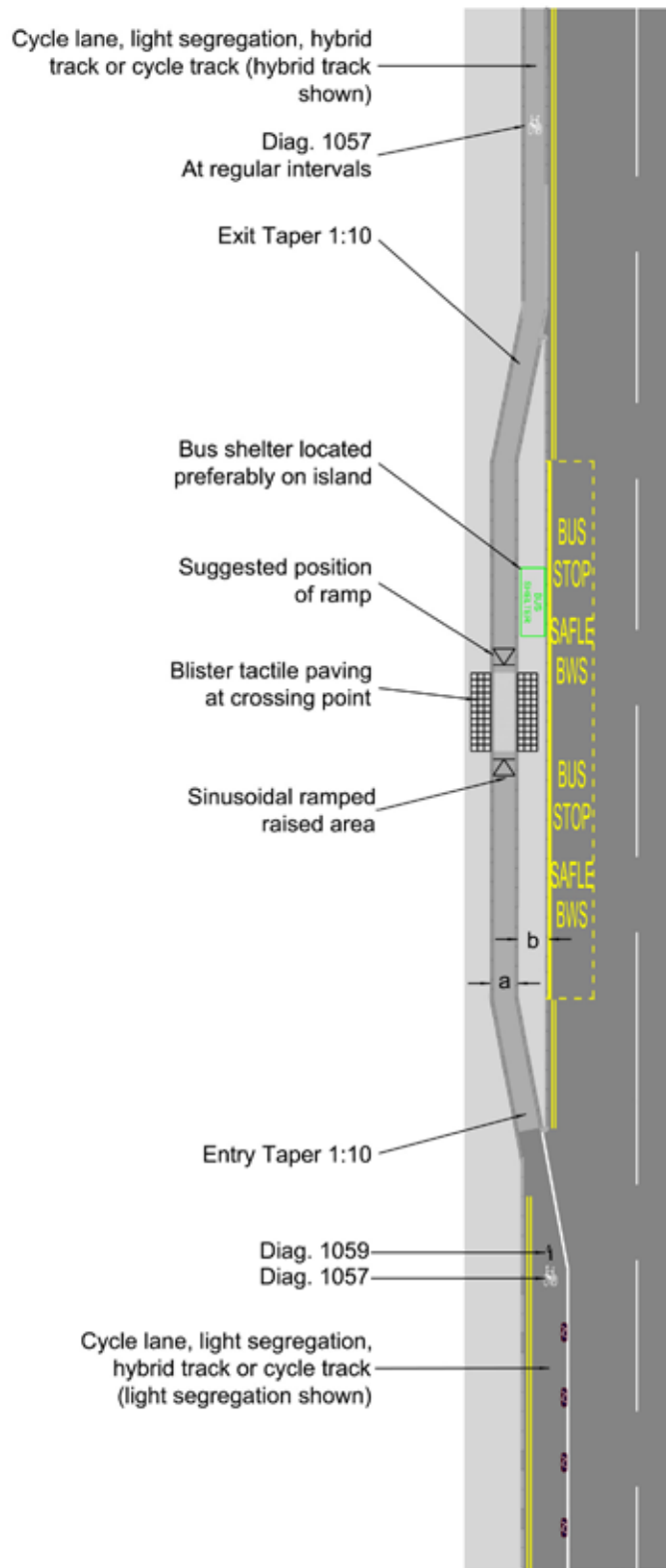
## Other Considerations

- This design can be used in conjunction with cycle lanes, cycle lanes with light segregation, hybrid cycle tracks and segregated off-carriageway tracks.
- Pedestrian crossing point(s) should be provided with dropped/flush kerbs.
- Bypasses should be kept clean and free from debris.
- Adequate drainage should be provided using cycle friendly gullies to prevent ponding and icing.



DE029

# Bus Stop: Island Bus Stop



Llywodraeth Cymru  
Welsh Government

Last Revised

September 2014

Do Not Scale Drawing

Drawing Produced By: Arup, 4 Pierhead Street, Capital Waterside, Cardiff, CF10 4QP

Copyright: Welsh Government

# DE030 Bus Stop: Bus Boarder

## Measure and Brief Description

Cyclists should be enabled to pass stationary buses so that they can maintain momentum and minimise delay. The Traffic Signs Manual advises that where cycle lanes in the usual position next to the kerb encounter bus stops they should be terminated and begin again after the bus cage. This requires cyclists to move out into general traffic, which does not meet their needs.

Provision of a bus boarder in line with the cycle lane/track will bring cyclists up to footway level onto a shared use area enabling them to continue across the bus boarder when it is clear or to cycle past pedestrians waiting at the bus stop. Careful consideration needs to be given in how to minimise conflict between cyclists and pedestrians - this option is best suited to bus stops and footways with low passenger and pedestrian volumes.

## Benefits

- Maintains route continuity.
- Eliminates the risk of conflict with buses.
- More comfortable and attractive, especially for less confident cyclists.
- Bus boarder provides step free access for bus users.

## Key Design Features

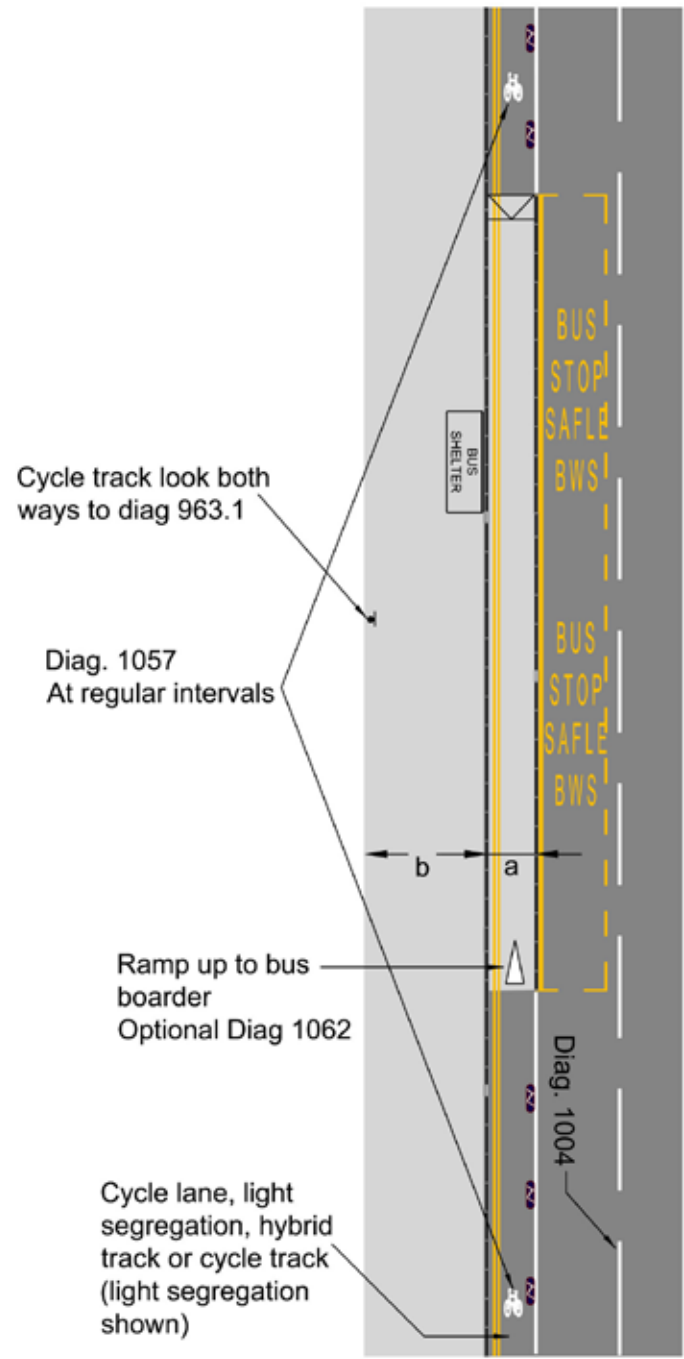
- Ramp up to footway level to help reduce cycle speeds.
- Where the difference between levels is small a short ramp may be appropriate.
- Bus shelters and flags should be placed at the back of the bus boarder.
- Sufficient space should be provided at the back of bus stop to minimise pedestrians needing to stand in the line of cycle track.
- Good intervisibility is required between pedestrians (those waiting for a bus as well as those passing) and cyclists, to minimise potential for conflict.
- The bus stop should be apparent to cyclists, who will need to be able to adjust their behaviour and speed to reflect the additional risk of conflict.

## Dimensions

- a - Bus boarder width Desirable minimum 2.0m, Absolute minimum 1.5m.
- b - Retained footway width Desirable minimum 3.0m, Absolute minimum 2.0m.

## Other Considerations

- Potential for conflict with pedestrians using the bus stop.
- This design can be considered in conjunction with cycle lanes, light segregation or one-way hybrid cycle tracks.



# DE031 Bus Stop: Shared Use

## Measure and Brief Description

Bus stops can pose a difficulty on two-way cycle tracks adjacent to the carriageway, as street furniture and waiting pedestrians associated with the bus stop can cause an obstruction and it will be difficult to maintain the width required for a fully separated track. Consequently an option is to share the entire width of the path past the bus stop.

## Benefits

- Maintains route continuity.
- Eliminates the risk of conflict with buses.
- Comfortable and attractive, especially for less confident cyclists.

## Key Design Features

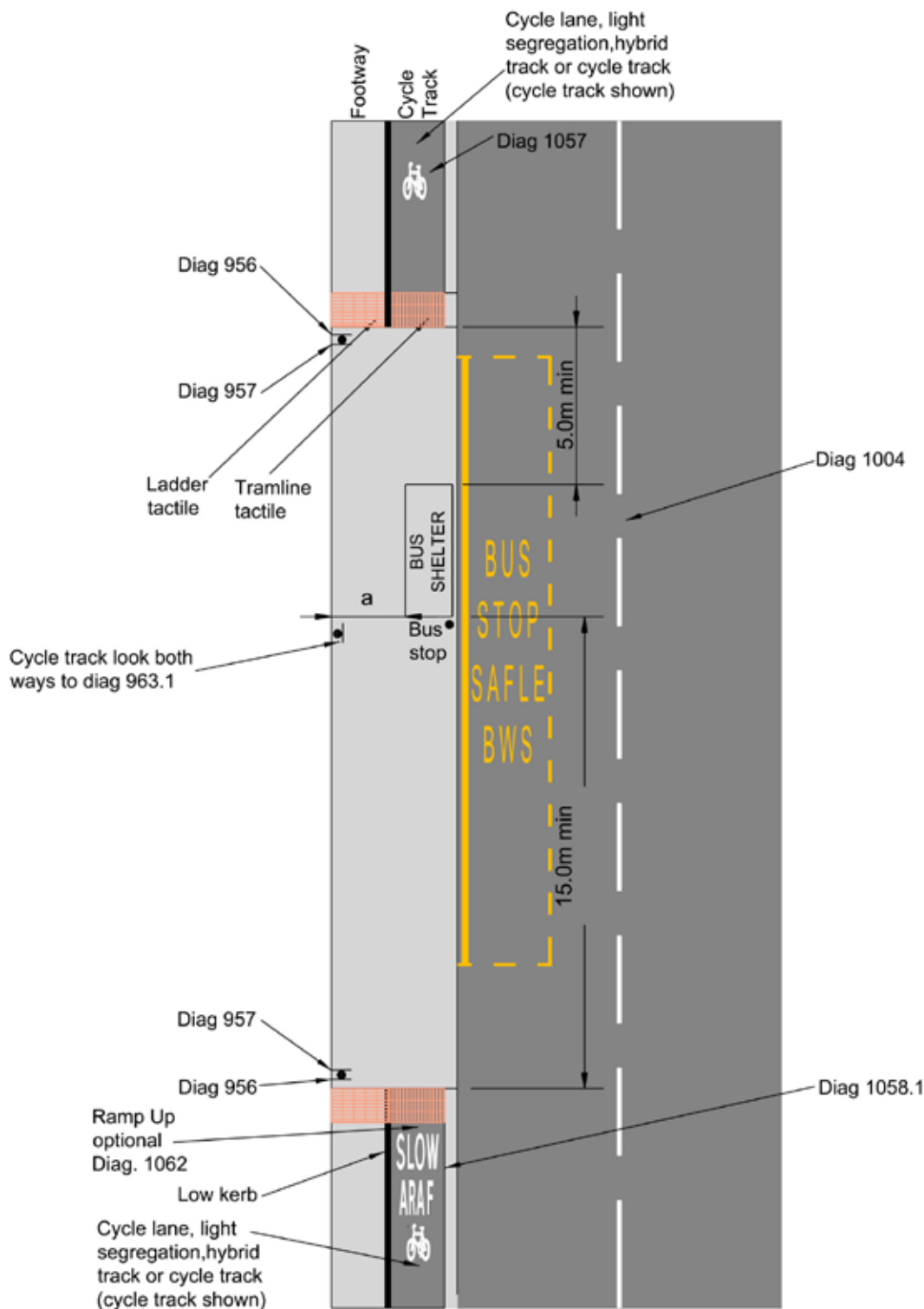
- Cycle track segregation ends each side of bus stop becoming a shared path.
- Shared path past bus stop to be kept clear of street furniture.
- There should be a clear space for passengers to wait where will not come into conflict with cyclists.
- Good intervisibility between pedestrians (those waiting for a bus as well as those passing) and cyclists, to minimise potential for conflict.
- The bus stop should be apparent to cyclists, who will need to be able to adjust their behaviour and speed to reflect the additional risk of conflict.

## Dimensions

- a – Retained shared use path width Desirable minimum 3.0m, Absolute minimum 2.0m.
- Cycle track should finish at least 15m before waiting area (in direction of general traffic) and continue 5m past.

## Other Considerations

- Potential for conflict with pedestrians using the bus stop or footway.



# DE032 Cycle Track Away From Road, Separated From Pedestrians

## Measure and Brief Description

Routes away from the road can provide a very good quality link for both pedestrians and cyclists. A separate parallel path for pedestrians is desirable, and sufficient width should be provided for each user group so that they do not encroach on the other users' path.

Physical segregation is generally preferred provided widths are adequate and this can be through a level difference or verge. Barriers are not desirable since they limit the effective width of the paths and are a particular hazard to cyclists. Segregation using only simple white lines (Diag 1049) (which are not detectable by blind users) or a raised white line delineator (Diag 1049.1), is an option but it is rarely respected by pedestrians (who have the legal right to use the cycle track) in practice, unless cycle flows are high or there is generous width, and should be avoided.

## Benefits

- Provides routes which are free from conflict with motor traffic.
- Segregated paths allow each group to move at their own desired pace and improve comfort and subjective safety.

## Key Design Features

- Footpaths and cycle tracks should be continuous.
- Flush kerbs with tactile paving at road crossings.
- Cycle tracks should not deflect more than 45° from cyclists' desire line and changes in height should be avoided.
- Machine-laid black bituminous surfacing should be used as it will make cycle journeys safer, more comfortable and helps distinguish cycle tracks from adjacent footways surfaced by pavements or slabs.

## Dimensions

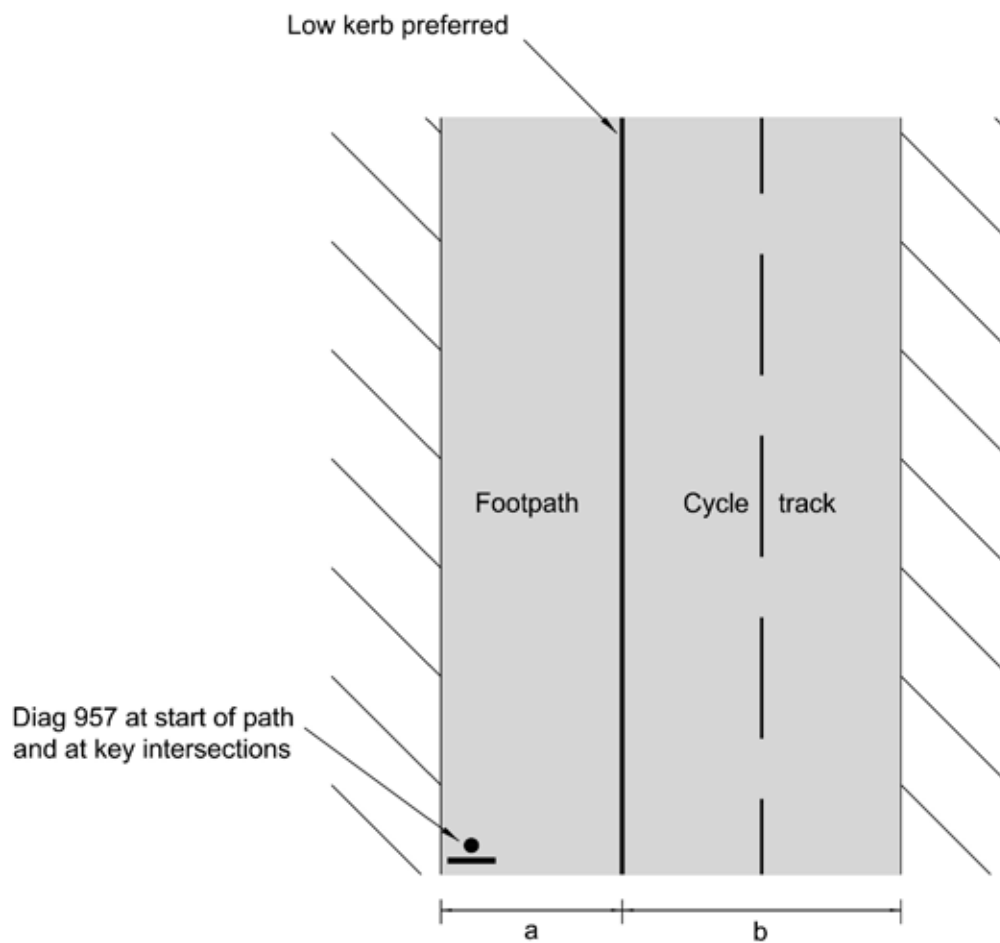
- a - The width for pedestrians should reflect the level and type of use forecast with an Absolute minimum of 2m, increasing to a Desirable minimum of 3.5m where there is frequent use by groups. 1.5m may be acceptable over short lengths, however – see DE001
- b - Cycle track width should be sufficient to accommodate the forecast level of use with a minimum of:
  - » Absolute minimum 2.5m, where the peak hour flow is less than 50/hr;
  - » Desirable minimum 3m, where it is 50-150/hr, 4m for cycle flows over 150/hr.
- Cycle tracks should include additional width where they are bounded by vertical features. Additional width required is
  - » Kerb up to 150mm high: add 200mm.
  - » Vertical feature 150-600mm high: add 250mm.
  - » Vertical feature above 600mm high: add 500mm.
- Verges separating pedestrian and cycle routes should be a minimum of 1m wide.

## Other Considerations

- Generally cycle tracks will be two-way.
- Centre lines should be marked on two-way cycle tracks.
- Lamp columns and other street furniture should be set back at least 0.5m from the edge of the cycle track.
- Path geometry, particularly radii, forward visibility and gradient, should reflect the user need criteria set out in Chapter 4.
- Paths used for utility journeys (all Active Travel Routes) should normally be lit.
- Access control features should not be installed unless absolutely necessary.

DE032

# Cycle Track Away From Road Separated From Pedestrians



Llywodraeth Cymru  
Welsh Government

Last Revised

September 2014

Do Not Scale Drawing

Drawing Produced By: Arup, 4 Pierhead Street, Capital Waterside, Cardiff, CF10 4QP

Copyright: Welsh Government



# DE033 Cycle Track Away From Road, Shared With Pedestrians

## Measure and Brief Description

Routes away from the road can provide a very good quality link for both pedestrians and cyclists. Where a cycle track is to be provided which will be shared with pedestrians, sufficient width must be provided for the two user groups to interact safely and in comfort. It is essential that developing the design of an unsegregated shared use track includes early consultation with relevant interested parties such as those representing people with disabilities, walkers and cyclists.

## Key Design Features

- Footpaths and cycle tracks should be continuous.
- Flush kerbs with tactile paving at road crossings.
- Cycle tracks should not deflect more than 45° from cyclists' desire line and constant changes in height should be avoided
- Machine-laid bituminous surfacing should be used as it will make cycle journeys safer and more comfortable.

## Dimensions

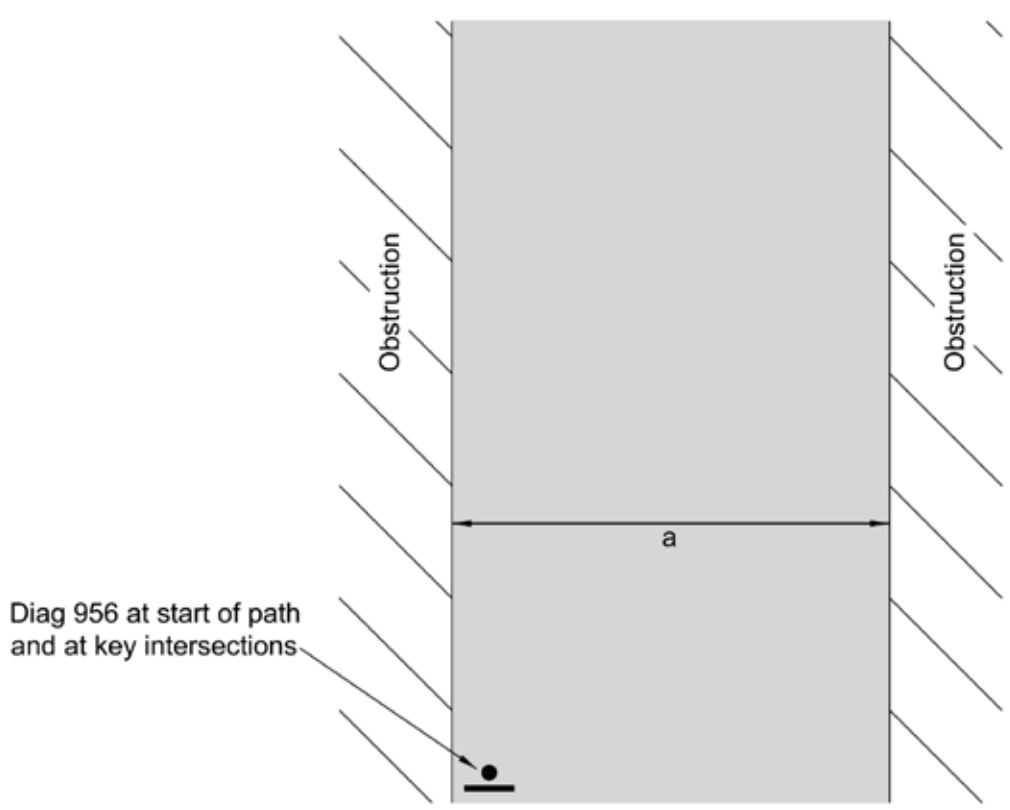
- a - width should reflect the level and type of use forecast with a minimum of 3m width on primary cycle routes, or 2.5m on less busy secondary routes. On particularly heavily trafficked routes it should be increased to 4m.
- Shared use cycle tracks should include additional width where they are bounded by vertical features. Only where there is open space on both sides is it is practical to use the whole track width to cycle. Additional width required is:
  - » Kerb up to 150mm high: add 200mm;
  - » Vertical feature 150-600mm high: add 250mm;
  - » Vertical feature above 600mm high: add 500mm.

## Other Considerations

- Generally cycle tracks will be two-way.
- Centre lines should be marked on two-way cycle tracks.
- Lamp columns and other street furniture should be set back at least 0.5m from the edge of the cycle track.
- Path geometry, particularly radii, forward visibility and gradient, should reflect the user need criteria set out in Chapter 4.
- Paths used for utility journeys (all Active Travel Routes) should normally be lit.
- Access control features should not be installed unless absolutely necessary.
- The British Horse Society recommends a desirable minimum width of 5.0m for new bridleways, which would be shared with pedestrians and cyclists.

DE033

# Cycle Track Away From Road Shared With Pedestrians



Diag 956 at start of path  
and at key intersections



Llywodraeth Cymru  
Welsh Government

Last Revised September 2014

Do Not Scale Drawing

Drawing Produced By: Arup, 4 Pierhead Street, Capital Waterside, Cardiff, CF10 4QP

Copyright: Welsh Government

# DE034 Transition Between Carriageway And Cycle Track

## Measure and Brief Description

'Merge' transitions involve cyclists joining the carriageway, a cycle lane, light segregated lane or hybrid track, from an off-carriageway cycle track. At 'diverge' transitions, cyclists carry out the reverse manoeuvre to join a parallel cycle track. The design of these transitions should provide a direct route for cyclists which does not require them to deviate significantly from their direction of travel, nor cross a kerb at an angle. At merges they should not need to give way to general traffic and be given space free from motor vehicles to enter into, defined by a cycle lane, light segregation or a hybrid track. The design should ensure that cyclists are clearly visible to motorists and that motorists are aware that cyclists are likely to be re-joining the carriageway.

As well as providing transitions between on- and off-road facilities along links, these transitions can be used on the approaches to controlled crossings or junctions to enable cyclists to leave the carriageway to use a facility. The design should minimise any conflict with pedestrians and other cyclists waiting at the crossing point.

## Benefits

- A smooth transition when joining or leaving the carriageway, without the need to give way or stop, will make a facility more comfortable and safe.

## Key Design Features

- Build-outs can be used to push vehicles away from cyclists rejoining the carriageway.
- Designs should take account of cyclists who are already using the carriageway at the merge point.
- Cyclists leaving the carriageway should not be brought into conflict with pedestrians.
- Cyclists should cross any kerbs at 90 degrees.
- Any tapers should be no sharper than 1:10.

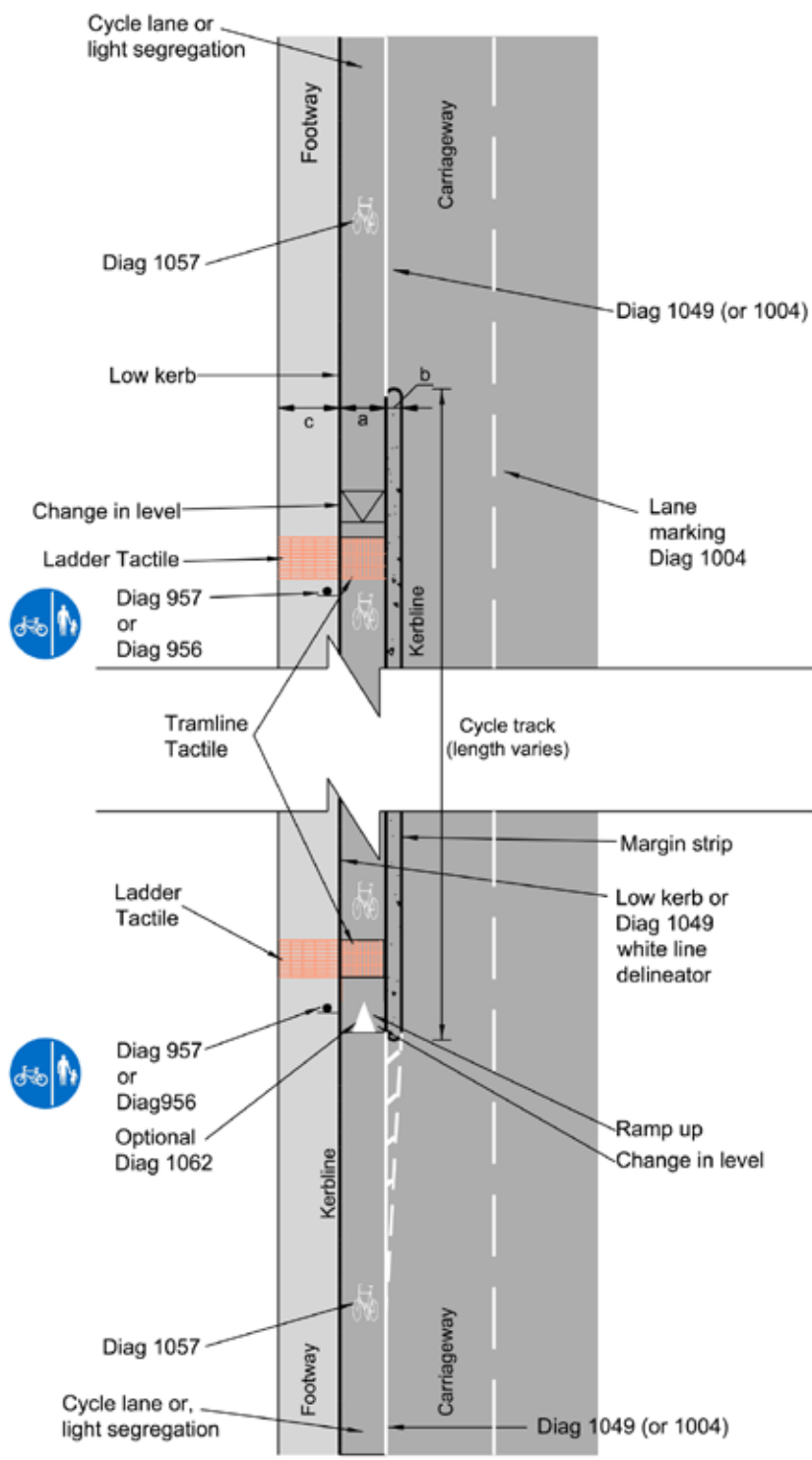
## Dimensions

- a – Width - desirable minimum 2m, absolute minimum 1.5m.
- b – Desirable margin strip separating cycle track from carriageway 0.5-1.0m.
- c - The width of the footway should reflect the level and type of use, based on level of service, Desirable minimum 2m width, increasing to 3.5m width where there is frequent use by groups. 1.5m may be acceptable over short lengths – see DE001.

## Other Considerations

- Generally cycle tracks will be two-way.
- Centre lines should be marked on two-way cycle tracks.
- Lamp columns and other street furniture should be set back at least 0.5m from the edge of the cycle track.
- Path geometry, particularly radii, forward visibility and gradient, should reflect the user need criteria set out in Chapter 4.
- Paths used for utility journeys (all Active Travel Routes) should normally be lit.
- Access control features should not be installed unless absolutely necessary.
- The British Horse Society recommends a desirable minimum width of 5.0m for new bridleways, which would be shared with pedestrians and cyclists.

# Transition Between Cycle Lane and Cycle Track



Last Revised	September 2014
Do Not Scale Drawing	
Drawing Produced By: Arup, 4 Pierhead Street, Capital Waterside, Cardiff, CF10 4QP	
Copyright: Welsh Government	

# DE035 Bus Lane

## Measure and Brief Description

The primary purpose of bus lanes is to improve the reliability of bus services by giving priority to buses over other vehicles on congested parts of the road network. Combined bus and cycle lanes can also be a useful feature for cyclists, enabling cyclists to share in the congestion avoidance and time-saving benefits provided to buses, as well as providing safer conditions for cycling. The default position is to allow cyclists to use bus lanes.

Bus lanes should not be regarded as part of designated Active Travel Networks unless bus flows are light and/or there is a cycle lane within the bus lane, and no other vehicles (eg taxis, motorcycles) are allowed.

## Benefits

- Cyclists can bypass traffic congestion and queues.
- Gives cyclists priority over general traffic at the locations and times where it is most needed.
- Cyclists using bus lanes have less traffic to interact with than if using a general traffic lane.
- There is a space buffer between the general traffic lane and the cyclist, (albeit occupied intermittently by buses).
- Cycle lanes within bus lanes are safer and more comfortable than shared bus lanes or general cycle lanes, since cyclists are passed by fewer vehicles

## Key Design Features

- Where bus lanes are proposed and are expected to form the main provision for cyclists along a route, a cycle lane should be provided within the bus lane wherever possible.
- The cycle lane would preferably be a mandatory lane, although authorities could use an advisory lane. This will also simplify TRO requirements,
- The hours of operation of bus lanes where cyclists are permitted should normally be 'at all times' to provide the highest benefit for cyclists. Where mandatory cycle lanes operate within bus lanes, they may operate full time even if the bus lane is part time.
- Diagram 1048 ('Bus Lane') markings must always be used in with-flow situations. The use of Diagram 1048.1 ('Bus and Cycle Lane') is reserved for contra-flow facilities only unless specially authorised.

## Dimensions

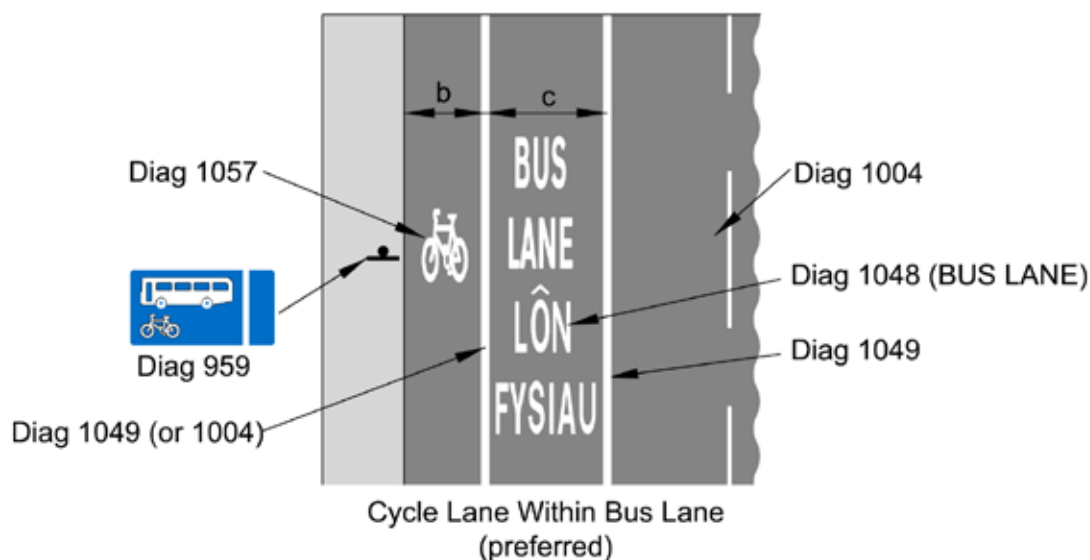
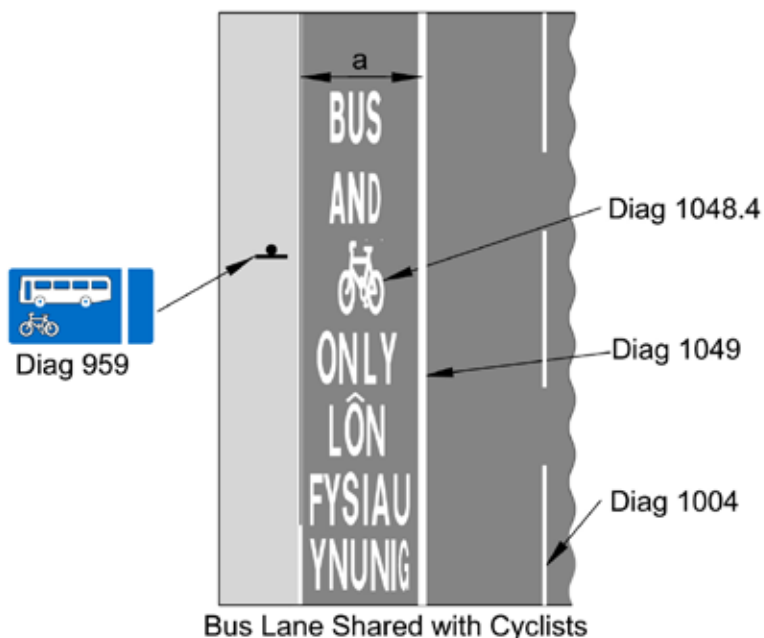
- a - A 4.0m bus lane with no cycle lane is the recommended minimum width where bus speeds and volumes are low. If widths of 4.0m on lower flow routes are not possible, then the bus lane should be restricted in width to 3.2m. This removes the dilemma for bus drivers of whether there is sufficient width to overtake a cyclist within the confines of the bus lane. Cycles are still allowed to use the Bus Lane, but buses will have to drive into the general traffic lane when overtaking cyclists. Bus lane widths of between 3.2m and 3.9m should not be provided as they leave insufficient room for buses to overtake cyclists or cyclists safely and comfortably. Where off-peak car parking or loading is permitted in a bus lane, the lane should be at least 4.0m and preferably 4.5m wide in order to allow cyclists to pass stationary motor vehicles without leaving the bus lane. It is also preferable to mark parking bays within bus lanes to encourage drivers to park close to the kerb.
- b - cycle lanes within bus lanes should be at least 1.5m wide and desirably 2m wide.
- c - the minimum width for the bus lane outside of the cycle lane should be a minimum of 2.7m.

## Other Considerations

- Where bus lanes are provided, care should be taken to ensure that provision for cyclists in the opposite direction is not compromised.
- There is often pressure on highway authorities to permit a wide range of other users to use bus lanes, including taxis, private hire vehicles and motorcycles. This can reduce the benefits afforded to cyclists and should be avoided.
- There should be a presumption in favour of designing contraflow bus lanes to be of sufficient width to accommodate cyclists. Where this is the case the widths referred to above for with-flow bus lanes will apply.
- Where bus-only links are provided, for example between two residential neighbourhoods, the design should normally include provision for cyclists.
- Authorities may choose to only place vertical signs indicating the presence of cycle lanes where there is a clear need to alter other road users to the presence of a cycle route.\*

## Further References

- Department for Transport (2003) – Traffic Signs Manual



Diag 1004  
to be laid over  
green screed



# DE036 Simple Uncontrolled Crossings (Walking, Shared Use or Cycle Only)

## Measure and Brief Description

This is the simplest form of pedestrian or cycle crossing where a footway, footpath or cycle track meets the road at a dropped kerb.

## Benefits

- Alerts drivers to the presence of crossing pedestrians and cyclists.
- Indicates to pedestrians a suitable crossing place.
- Relatively cheap to install.

## Key Design Features

- Tactile paving to be provided at dropped kerbs.
- A coloured surface may be useful to highlight the presence of the crossing to motor traffic.
- If the road has a speed limit of 30 mph or less, the crossing may be placed on a flat topped road hump. If so, it needs to be made clear to cyclists that they must give way when crossing.
- Road humps must comply with the Highways Act 1980, Sections 90A to 90F.
- Where it is not clear to cyclists approaching the crossing that they are about to meet a road, it may be worthwhile adding markings (and possibly signs) indicating that they should give way.
- On single carriageway roads with two lanes where the national speed limit of 60mph applies or on other rural roads where a lower speed limit is in place, consideration should be given to additional measures such as light coloured antiskid surfacing for 50m either side of the crossing, rumble strips on the approaches, localised visual narrowing in vicinity of crossing and Diagram 950 warning signs on the approaches.

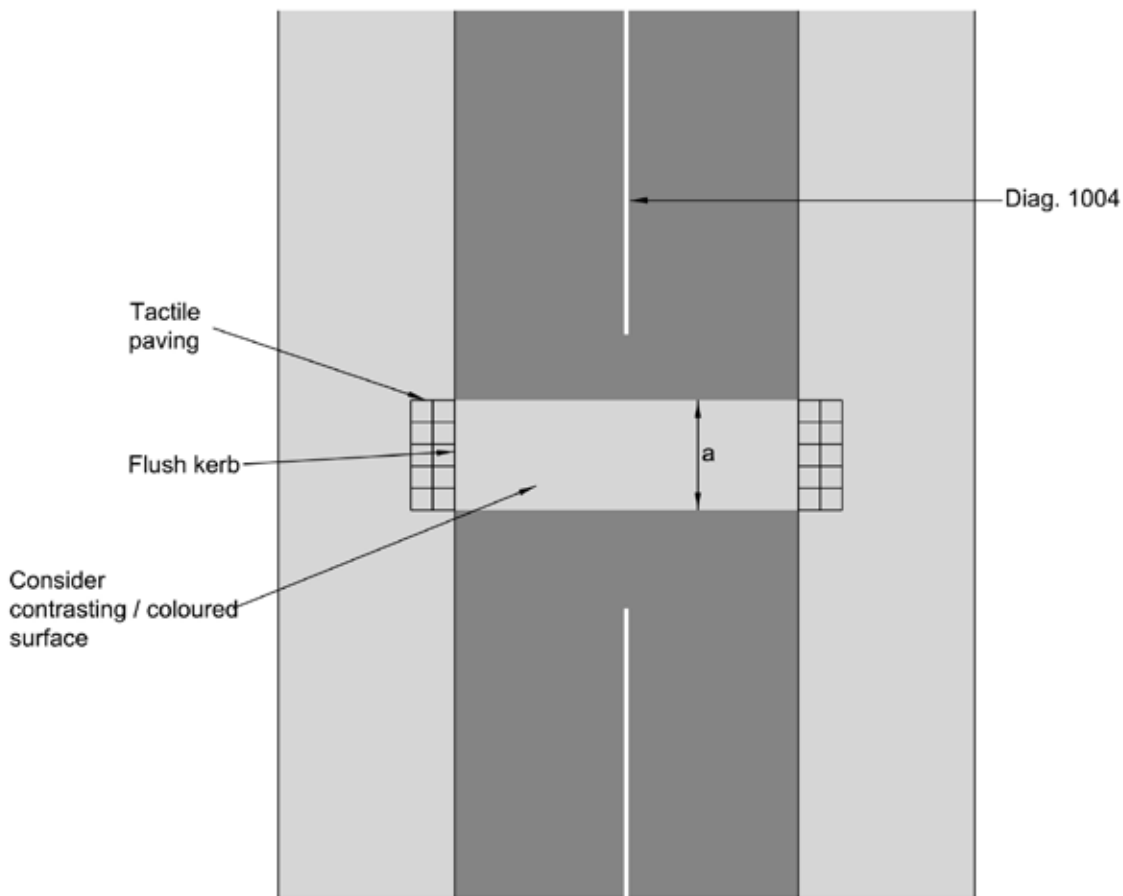
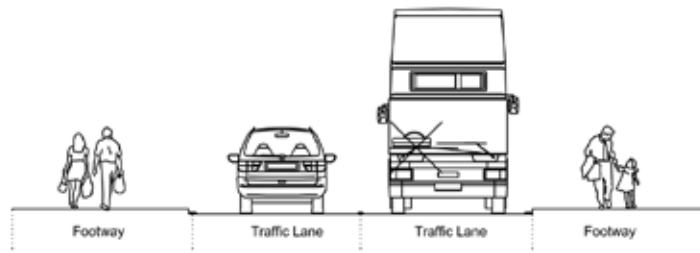
## Dimensions

- Width of crossing (a) to be at least as wide as the path either side. On pedestrian only routes this should be 2m min, on shared use paths, 3m min

## Other Considerations

- Any coloured surface needs to maintain a good condition to remain effective.
- The effect of parked vehicles in the vicinity of an uncontrolled crossing should be considered and if necessary parking restrictions imposed to maintain adequate visibility.
- Vehicle crossovers are not suitable as pedestrian crossing points and care should be taken over the siting of crossings relative to crossovers so as not to cause confusion to users.
- Build outs can reduce the crossing distance, and in some situations will aid visibility, but can impede on-road cyclists. Designers should understand the impact that creating a better crossing point can have on a cyclist already on the road.
- Physical changes to the kerb lines can be costly, but reducing the carriageway width is an effective solution.
- In rural locations detectors on the approach paths can be used to trigger vehicle activated signs to alert motor traffic of the presence of an infrequently used crossing only when there are cyclists or pedestrians present.





# DE037 Cycle Priority Crossing

## Measure and Brief Description

Where a cycle track crosses a carriageway, the cycle track can be given priority over vehicles travelling along it. Care needs to be taken to ensure it is clear to motorists that they must give way, and that there is sufficient visibility along the cycle track. This type of crossing is best suited to relatively lightly trafficked slower speed roads.

## Benefits

- Continuity of cycle route.
- Minimises delay and effort for cyclists.
- Affords visible priority to cyclists.
- Whilst this crossing design does not afford legal priority to pedestrians, traffic speeds are reduced and drivers will often informally cede priority to pedestrians.

## Key Design Features

- Priority cycle crossings are generally suitable where main road flows are up to 4,000 vehicles per day, and speeds are up to 30mph.
- A road hump is not a legal requirement\*, but is desirable to reduce traffic speeds locally and encourage drivers to give way.
- Road humps must comply with the Highways (Road Humps) Regulations 1999
- Tactile paving to be provided to alert visually-impaired pedestrians.
- A coloured surface may be useful to highlight the presence of the crossing to motor traffic.
- Care should be taken to provide sufficient visibility. The crossing itself and its immediate approaches should be visible and readily apparent to approaching motorists at their stopping sight distance. The crossing should be in a lit area.
- Although not mandatory, give way signs to diagram 602 will usually be required as the cycle track crossing and 1003 road markings may not be sufficiently obvious to approaching drivers on their own. The give way sign should be supplemented with a variant of diagram 962.1, varied to read 'Cycle track', with Welsh Government authorisation.

## Dimensions

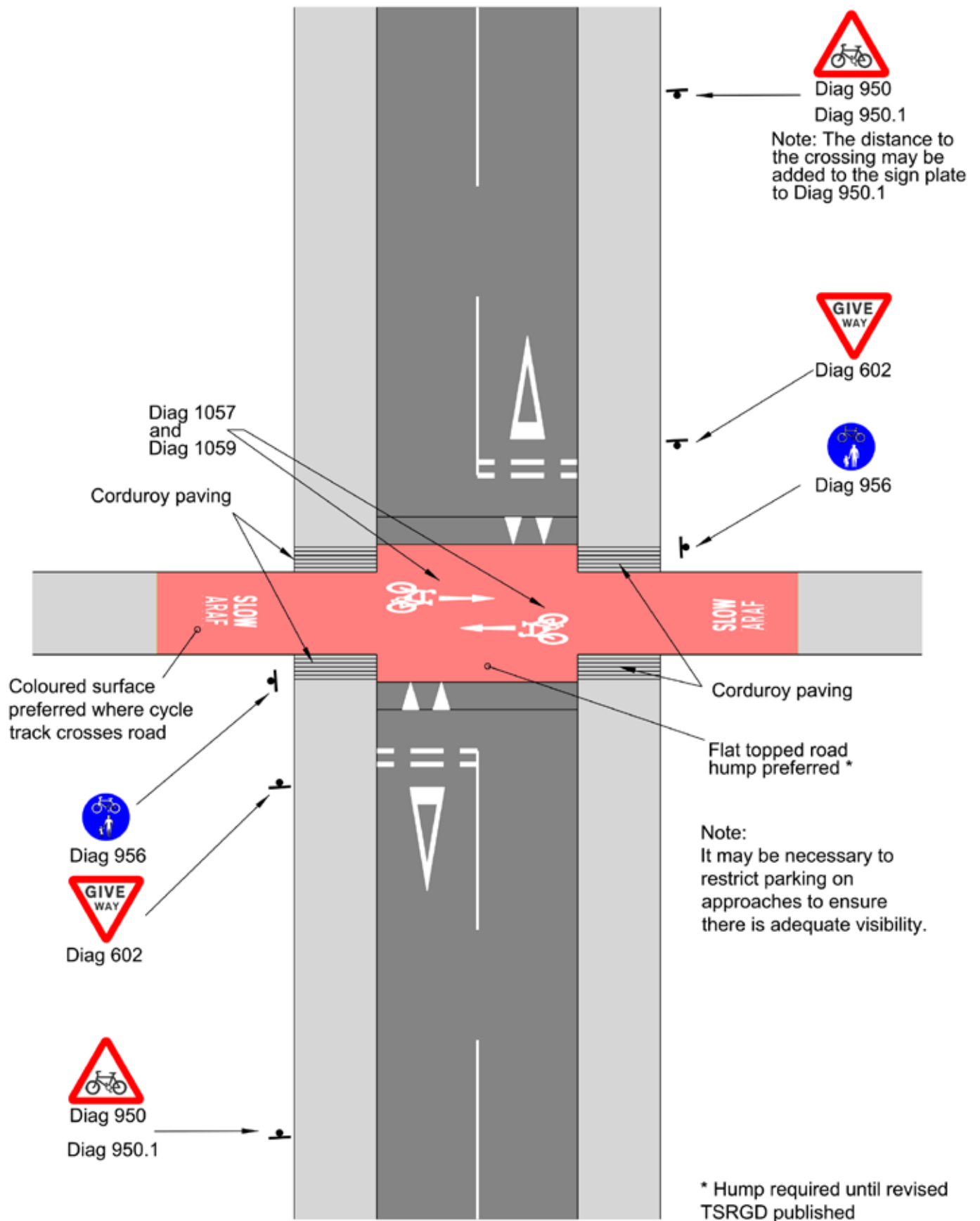
- Width of crossing to be at least as wide as the cycle track either side, 3m min.

## Other Considerations

- Where cycle approach speeds are high or visibility restricted it is preferable to use path approach geometry or humps to slow cyclists. Barriers should not be used.
- Cycle priority crossings may also have central refuges (DE038)

## Further References

- Department for Transport (2003) – Traffic Signs Manual



# DE038 Uncontrolled Crossing With Central Refuge

## Measure and Brief Description

Where the crossing of a road cannot easily be carried out in one stage due to the speed and volume of traffic or the width of the carriageway it will be necessary to provide a refuge for pedestrians and possibly cyclists to wait safely and make the crossing in two sections.

## Benefits

- A high quality refuge crossing can considerably reduce the time needed to cross a busy road.
- Drivers are more likely to informally cede priority to pedestrians and/or cyclists where there is a refuge, as they know that they are inviting people to cross to a safe place.

## Key Design Features

- Central refuges should be at least as wide as the approach paths.
- Crossings should be in a straight line.
- Refuges should normally be kerbed in order to provide a degree of protection and subjective safety to users.
- Flush kerbs and tactile paving should be provided in line with the dropped kerbs at the edge of the road, in the refuge and on the footways on either side.
- The refuge will often (but not always) need to be marked with bollards facing approaching traffic. These bollards may need to be illuminated in some circumstances - see Traffic Advisory Leaflet 3/13 and TSRGD.
- On single carriageway roads with two lanes where the national speed limit of 60mph applies or on other rural roads where a lower speed limit is in place, consideration should be given to additional measures such as light coloured antiskid surfacing for 50m either side of the crossing, rumble strips on the approaches, and beacons and Diag 950 warning signs on the approaches.

## Dimensions

- a - Width of crossing to be at least as wide as the path either side. On pedestrian only routes this should be 2m min, on cycle tracks or shared use paths 3m min.
- b - Depth of pedestrian refuge should be a minimum of 2m to accommodate a wheelchair and pusher, or 4m where pedestrian flow > 600/hour; absolute minimum 1.2m.
- b - Depth of refuge for use by cyclists should be a minimum of 2m, or 2.4m on roads subject to national speed limit. A depth of 3m will accommodate a cycle towing a trailer, or a tandem.
- c - Refuges should not be designed to retain a running lane width of between 3.2m – 3.9m. This will encourage motorists to think that they can squeeze through ahead of cyclists.

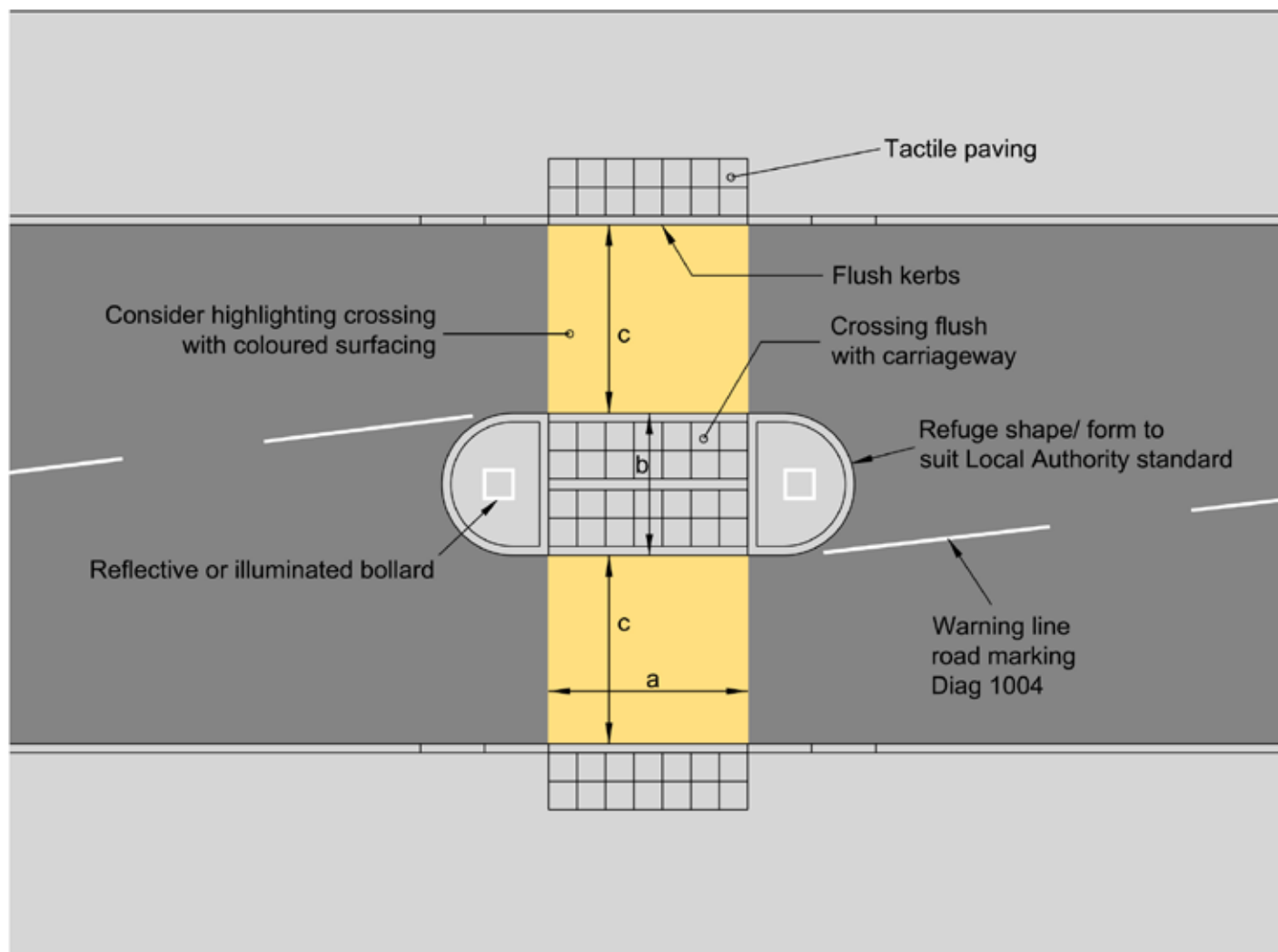
## Other Considerations

- The size of refuge should cater for peak flows in excess of current usage and allow for groups of pedestrians or cyclists (especially families) to wait together.
- The effect of parked vehicles in the vicinity of a refuge should be considered and if necessary parking restrictions imposed to maintain adequate visibility.
- Clutter-free (eg guardrailing) median islands will act as refuges for pedestrian and cyclist crossing movements and improve visibility and the streetscene.
- In rural locations detectors on the approach paths can be used to trigger vehicle activated signs to alert motor traffic of the presence of an infrequently used crossing only when there are cyclists or pedestrians present.

## Further References

- Department for Transport (2013) - Traffic Advisory Leaflet 3/13. Traffic Bollards and Low Level Traffic Signs.

## DE038 Uncontrolled Crossing With Central Refuge



# DE039 Side Road Entry Treatment

## Measure and Brief Description

Pedestrian crossings will be usually be provided across minor roads at side road junctions, if only in the form of dropped kerbs. Side road entry treatments involve raising and narrowing the mouth of the junction to make it easier and safer for pedestrians to cross the minor arm by reducing the speeds of turning vehicles, shortening the length of the crossing and providing a level route. The side road entry treatment also encourages drivers to give way to pedestrians who have started to cross.

## Benefits

- Side road entry treatments make it easier and more convenient for pedestrians to cross the side road
- They also provide safety benefits to cyclists, helping to prevent collisions with motor vehicles turning into and out of the side road

## Key Design Features

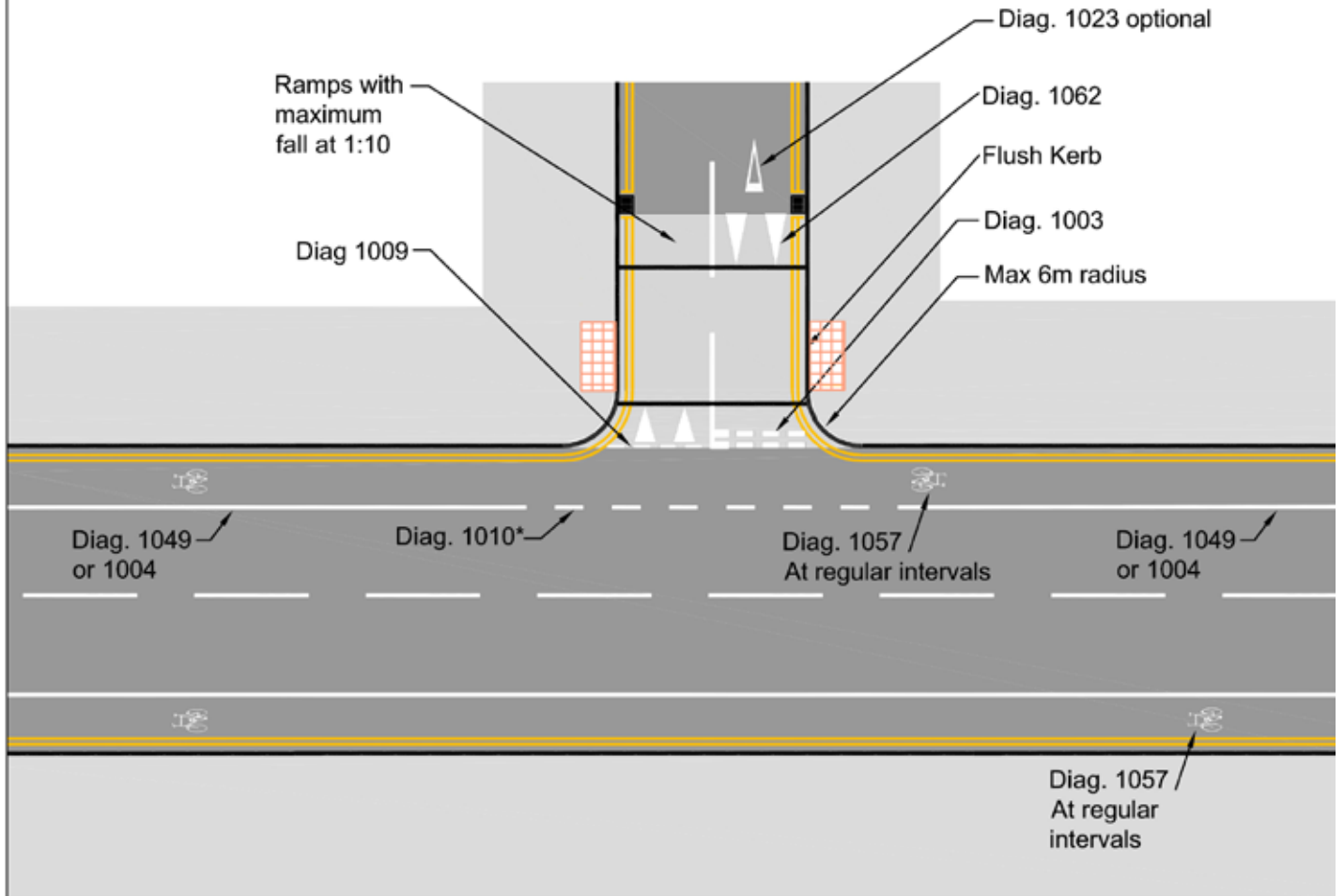
- Raising the carriageway to footway level across the mouth of the side road.
- Narrowing the side road to shorten the crossing distance and reduce traffic speeds.
- Tightening the corner radii of side road junctions which will slow down turning vehicles and enable the crossing point to be closer to the desire line.
- The top of the raised table should be constructed in material which contrasts with the carriageway to indicate to drivers that they should treat it differently. It may be paved in a similar material to the footway on either side.
- Tactile paving to be provided at the pedestrian crossing points.

## Dimensions

- a - Corner radii – Desirable maximum 3m, Absolute maximum 6m.

## Other Considerations

- Raised tables are a form of traffic calming and as such cannot be used on roads with a speed limit greater than 40 mph.
- Consideration should be gradient of the ramp so as not to create a hazard for motorcycles and cyclists turning into the side road.
- Corner radii will depend the swept path requirements of vehicles turning into or out of the side road (allowing for vehicles to cross centrelines unless flows are high).
- Tight corner radii will enable pedestrian crossing points to be provided on the desire line.
- Bollards may be provided to prevent over-run on corners.
- Strengthened corners may be necessary if over-run is to be expected.
- Care should be taken to ensure adequate drainage provision to prevent ponding of water at the bottom of the ramps with a raised table, or in the corners of build outs.



Last Revised September 2014

Do Not Scale Drawing

Drawing Produced By: Arup, 4 Pierhead Street, Capital Waterside, Cardiff, CF10 4QP

Copyright: Welsh Government

December 2014



# DE040 Blended Side Road Entry Treatment

## Measure and Brief Description

Pedestrian crossings will usually be provided at side road junctions, if only in the form of dropped kerbs. Blended side road entry treatments involve continuing the footway across the mouth of the junction without any change to make it easier and safer for pedestrians to cross by reducing the speeds of turning vehicles, shortening the length of the crossing and providing a level route. The continuous footway strongly indicates to drivers that they should give way to pedestrians using the footway.

## Benefits

- Blended side road entry treatments make it easier and more convenient for pedestrians to cross the side road
- They also provide safety benefits to cyclists, helping to prevent collisions with motor vehicles turning into and out of the side road

## Key Design Features

- Raising the carriageway to footway level across the mouth of the side road.
- Narrowing the side road to shorten the crossing distance and reduce traffic speeds.
- Tightening the corner radii of side road junctions which will slow down turning vehicles and enable the crossing point to be closer to the desire line.
- The top of the raised table should be constructed in material which contrasts with the carriageway to indicate to drivers that they should treat it differently. It may be paved in a similar material to the footway on either side.
- Tactile paving is not provided as it suggests that pedestrians should give way to turning vehicles. The design relies on the fact that vehicles are crossing over a continuous footway.

## Dimensions

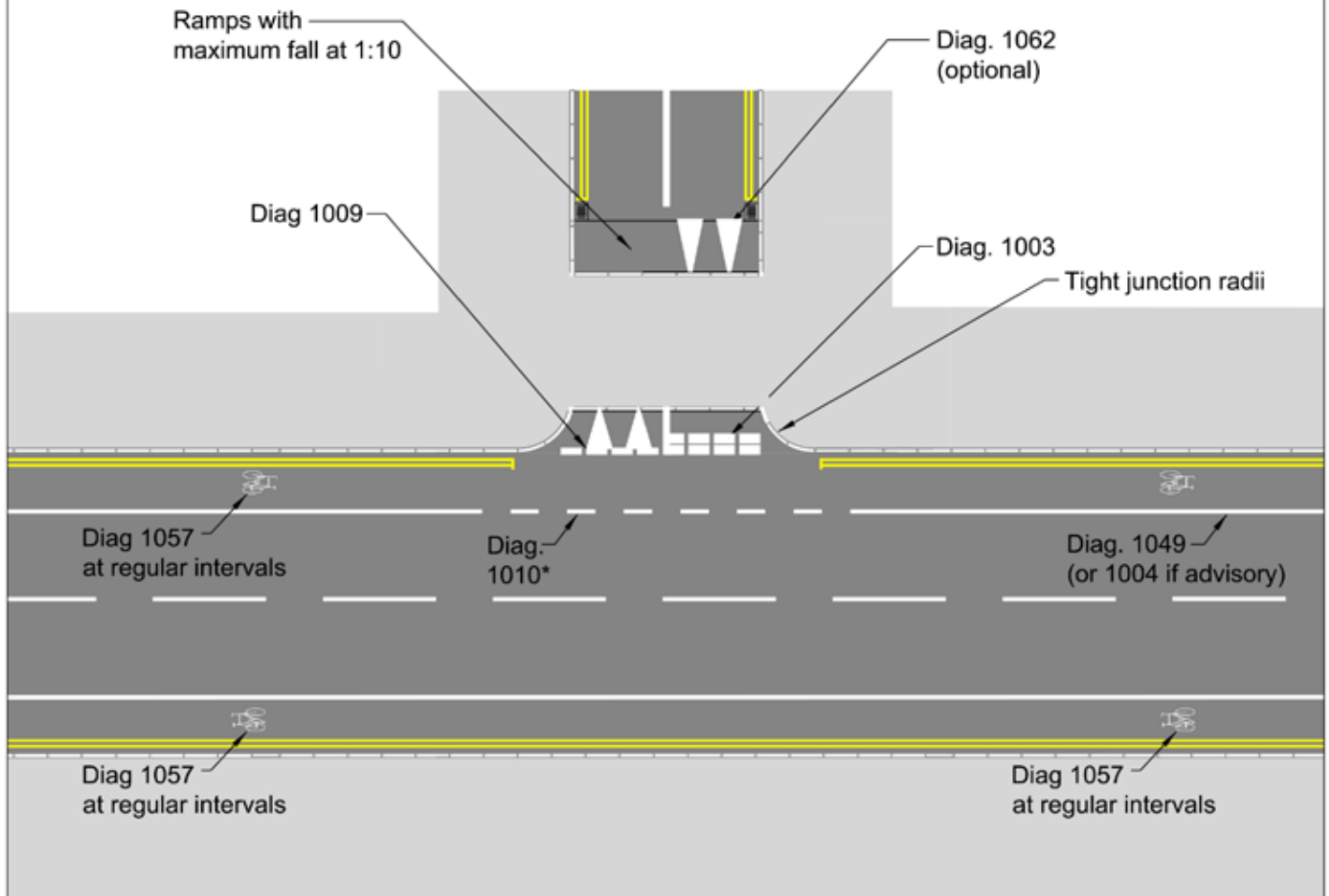
- a - Corner radii – Desirable maximum 3m, Absolute maximum 6m.

## Other Considerations

- Raised tables are a form of traffic calming and as such cannot be used on roads with a speed limit greater than 40 mph.
- Consideration should be given to the gradient of the ramp so as not to create a hazard for motorcycles and cyclists turning into the side road.
- Corner radii will depend on the swept path requirements of vehicles turning into or out of the side road (allowing for vehicles to cross centrelines unless flows are high).
- Tight corner radii will enable pedestrian crossing points to be provided on the desire line.
- Bollards may be provided to prevent over-run on corners.
- Strengthened corners may be necessary if over-run is to be expected.
- Care should be taken to ensure adequate drainage provision to prevent ponding of water at the bottom of the ramps with a raised table, or in the corners of build outs.

DE040

# Blended Side Road Entry Treatment



Llywodraeth Cymru  
Welsh Government

Last Revised

September 2014

Do Not Scale Drawing

Drawing Produced By: Arup, 4 Pierhead Street, Capital Waterside, Cardiff, CF10 4QP

Copyright: Welsh Government

# DE041 Central Median Strip

## Measure and Brief Description

A central median strip is a long paved area of different coloured or textured surfacing in the centre of a carriageway which provides space for pedestrians to wait in while crossing a road in two stages at any point along its length.

## Benefits

- Central median strips enable pedestrians to cross carriageways in two stages away from formal crossing points.
- This is particularly useful where crossing movements are distributed along a significant length, for example along a shopping street.
- These strips can also enhance the character of a highway and help to lower vehicle speeds. They also provide safety benefits to cyclists, helping to prevent collisions with motor vehicles turning into and out of the side road

## Key Design Features

- The width of the central median needs to be sufficient for a pedestrian to wait safely in the median for a gap in the traffic.
- The median may be constructed to enable vehicular overrun, or be kerbed to prevent vehicular overrun.
- Kerbed medians will give the most confidence to pedestrians crossing. Central medians can be designed to be overrun so that the carriageways can be kept narrow but still allow for vehicles to pass stationary buses etc.
- Strips that are designed to be overrun can be flush or domed and/or constructed in rough surfacing so that vehicles travel slowly when travelling across the median.
- Designated crossing points may still be provided at intervals, with flush kerbs on the median and at the kerbs on the opposite side of the carriageways. Tactile paving should be provided at these flush kerbs. Raising the carriageway to footway level across the mouth of the side road.

## Dimensions

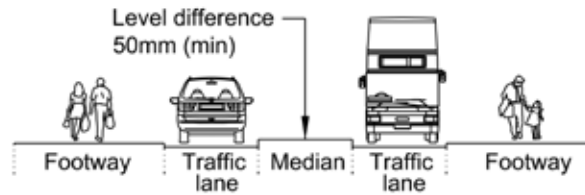
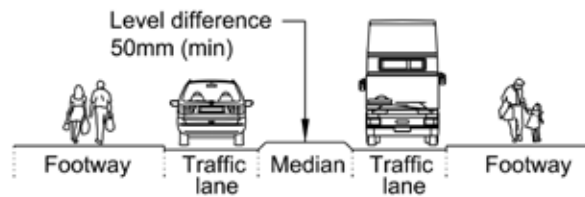
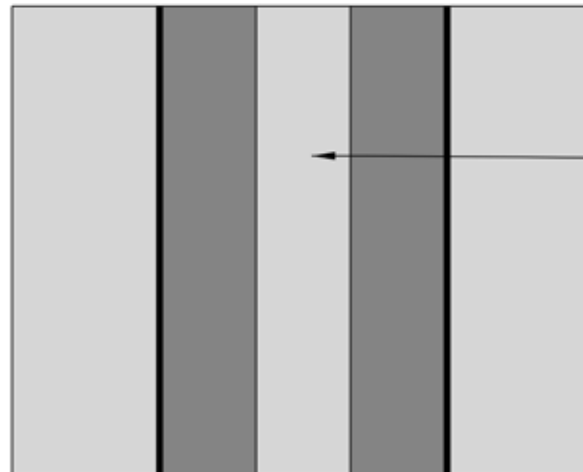
- a - Lane width either side to be below 3.2m or above 3.9m, avoiding the critical lane width range for cyclists.
- b – Width of median strip should be a desirable minimum of 2m to accommodate a wheelchair and the person pushing and an absolute minimum of 1.2m.
- Minimum kerb height of 60mm is recommended, with an absolute minimum of 50mm.

## Other Considerations

- Unless kerbed, the form of construction of the median strip will need to accommodate vehicular overrun.
- Subject to vehicle tracking requirements, trees and planting can be placed in the central median.

DE041

## Central Median Strip

Kerbed MedianHumped MedianFlush Median

A material of differential colour, tone and / or surfacing should be used for the median strip



Llywodraeth Cymru  
Welsh Government

Last Revised

September 2014

Do Not Scale Drawing

Drawing Produced By: Arup, 4 Pierhead Street, Capital Waterside, Cardiff, CF10 4QP

Copyright: Welsh Government

# DE042 Zebra Crossing

## Measure and Brief Description

A Zebra is un-signalised crossing marked on the carriageway with transverse black and white stripes and yellow flashing globes (belisha beacons) on black and white striped poles at each side of the crossing. A driver must stop at a zebra crossing when a pedestrian starts to cross;

Zebra crossings are not designed to accommodate cyclists. Parallel crossings for pedestrians and cyclists are shown on DE043 and cycle-only priority crossings on DE037.

## Benefits

- Zebra crossings provide relatively low-cost pedestrian priority crossing facilities which give an immediate response to pedestrians' need to cross.
- They can be placed closer to junctions than signalised crossings, reducing the need to deviate from desire lines.
- Unless pedestrian flows are very high they result in lower delays to vehicles. Central median strips enable pedestrians to cross carriageways in two stages away from formal crossing points.

## Key Design Features

- There should be adequate visibility to a zebra crossing to ensure that approaching motorists can see a pedestrian about to cross the road.
- Zebra crossings may be sited on a flat-topped road hump (raised table) to slow traffic and highlight the presence of the crossing.
- Zebra crossings may either cross a full width carriageway in a single stage or comprise two crossings with a central refuge.
- Zebra crossings can be used across minor junctions close to the give way line.
- Zebra crossings should be at least five metres from a side road junction, measured from the driver's position in the adjacent road.
- When provided on the approach or exit from a roundabout Zebra crossings should be located between 5m and 20m from the give way line.
- 8 zig zag markings are normally provided on either side of the crossing, which prevent parking, loading or overtaking. The maximum number is 18 and the minimum number is 2.
- Zig zag markings can be placed up to 2m from the kerbline so that space for cycling can be maintained up to the crossing.\*
- Tactile paving to be provided.

## Dimensions

- a – Crossing width 4m min, 10m max.
- b – Distance of give way line to crossing 1.1m min, 3m max.

## Other Considerations

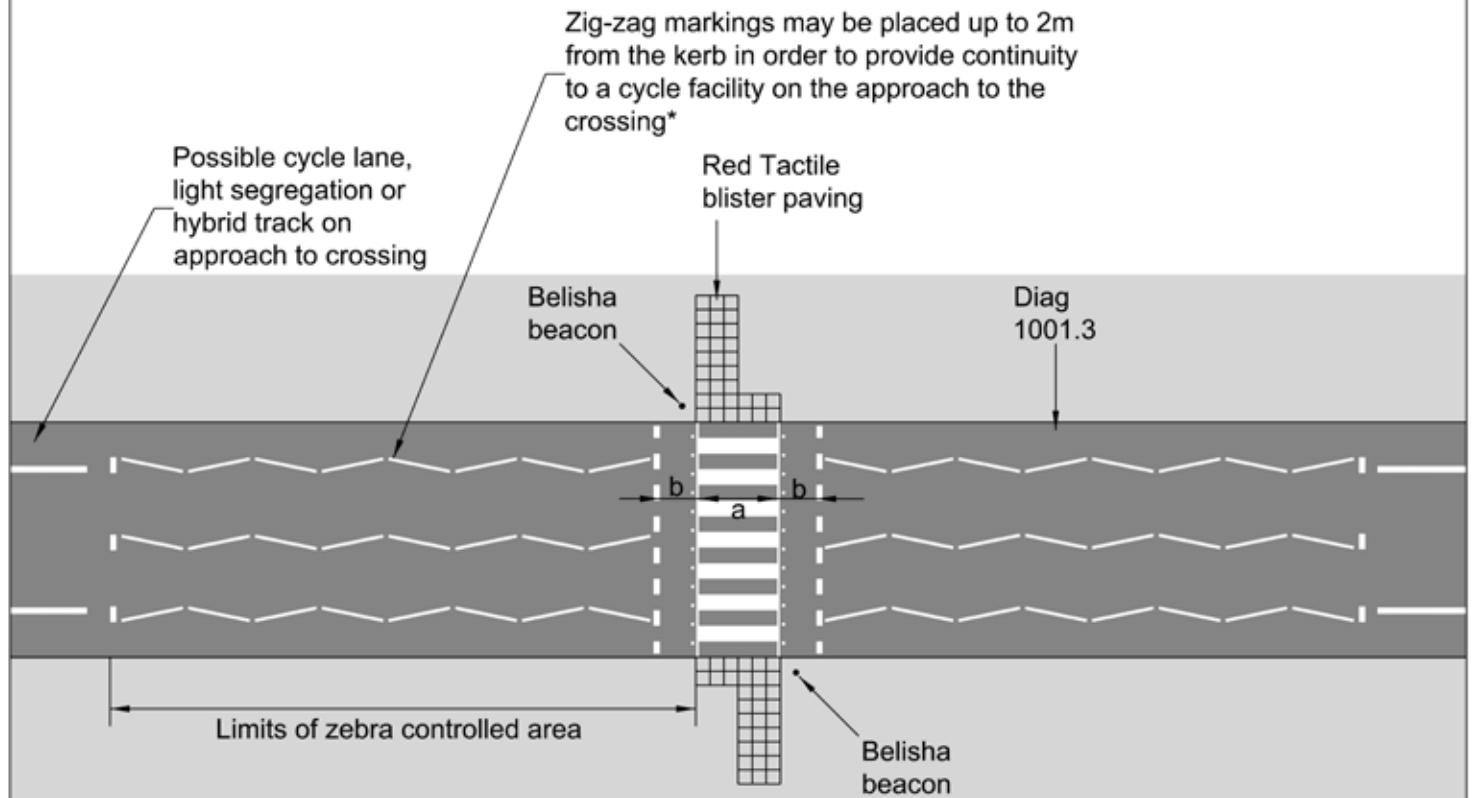
- A blind person would not start to cross until sure that vehicles have stopped and would therefore seek a pedestrian controlled signal crossing. Other groups of pedestrians, including people with learning impairments and older people may feel safer and more comfortable using signalised crossings.
- Zebra crossings are unsuitable in locations where the 85th percentile vehicle speed is greater than 35mph or where there would be regular congestion resulting from high vehicle or pedestrian flows.
- Where a zebra crossing is used on a road of two lanes or more consideration should be given to whether a vehicle stopped in the nearside lane will obstruct visibility to a crossing pedestrian from a vehicle in the off-side lane.
- Crossings may be divided by a refuge – see DE038. a – Crossing width 4m min, 10m max.

## Further References

- Department for Transport (2003) – Traffic Signs Manual
- Department for Transport (1995) Local Transport Note 1/95: The Assessment of Pedestrian Crossings
- Department for Transport (1995) – Local Transport Note 2/95: The Design of Pedestrian Crossings.

DE042

## Zebra Crossing



Llywodraeth Cymru  
Welsh Government

Last Revised

September 2014

Do Not Scale Drawing

Drawing Produced By: Arup, 4 Pierhead Street, Capital Waterside, Cardiff, CF10 4QP

Copyright: Welsh Government

# DE043 Parallel Crossing for Pedestrians and Cyclists\*

## Measure and Brief Description

A parallel crossing for pedestrians and cyclists is expected to be introduced in the forthcoming revision to TSRGD. It is un-signalised crossing marked on the carriageway with transverse black and white stripes to indicate the pedestrian crossing and Elephants Footprint/Diagram 1057 markings to indicate the cycle crossing, together with yellow flashing globes (belisha beacons) on black and white striped poles at each side of the overall crossing. A driver must stop on the approach to the crossing when a pedestrian or cyclist starts to cross.

## Benefits

- Parallel pedestrian/cycle crossings provide relatively low-cost facilities which give an immediate response to pedestrians' and cyclists' need to cross.
- They can be placed closer to junctions than signalised crossings, reducing the need to deviate from desire lines.
- Unless pedestrian or cycle flows are very high they result in lower delays to vehicles.

## Key Design Features

- There should be adequate visibility to a crossing to ensure that approaching motorists can see a pedestrian or cyclist about to cross the road.
- Crossings may either cross a full width carriageway in a single stage or comprise two crossings with a central refuge.
- Crossings can be used across minor junctions close to the give way line.
- Crossings should be at least five metres from a side road junction, measured from the driver's position in the adjacent road.
- When provided on the approach or exit from a roundabout crossings should be located between 5m and 20m from the give way line.
- 8 zig zag markings are normally provided on either side of the crossing, which prevent parking, loading or overtaking. The maximum number is 18 and the minimum number is 2.
- Zig zag markings can be placed up to 2m from the kerbline so that space for cycling can be maintained up to the crossing.\*
- Tactile paving to be provided.

## Dimensions

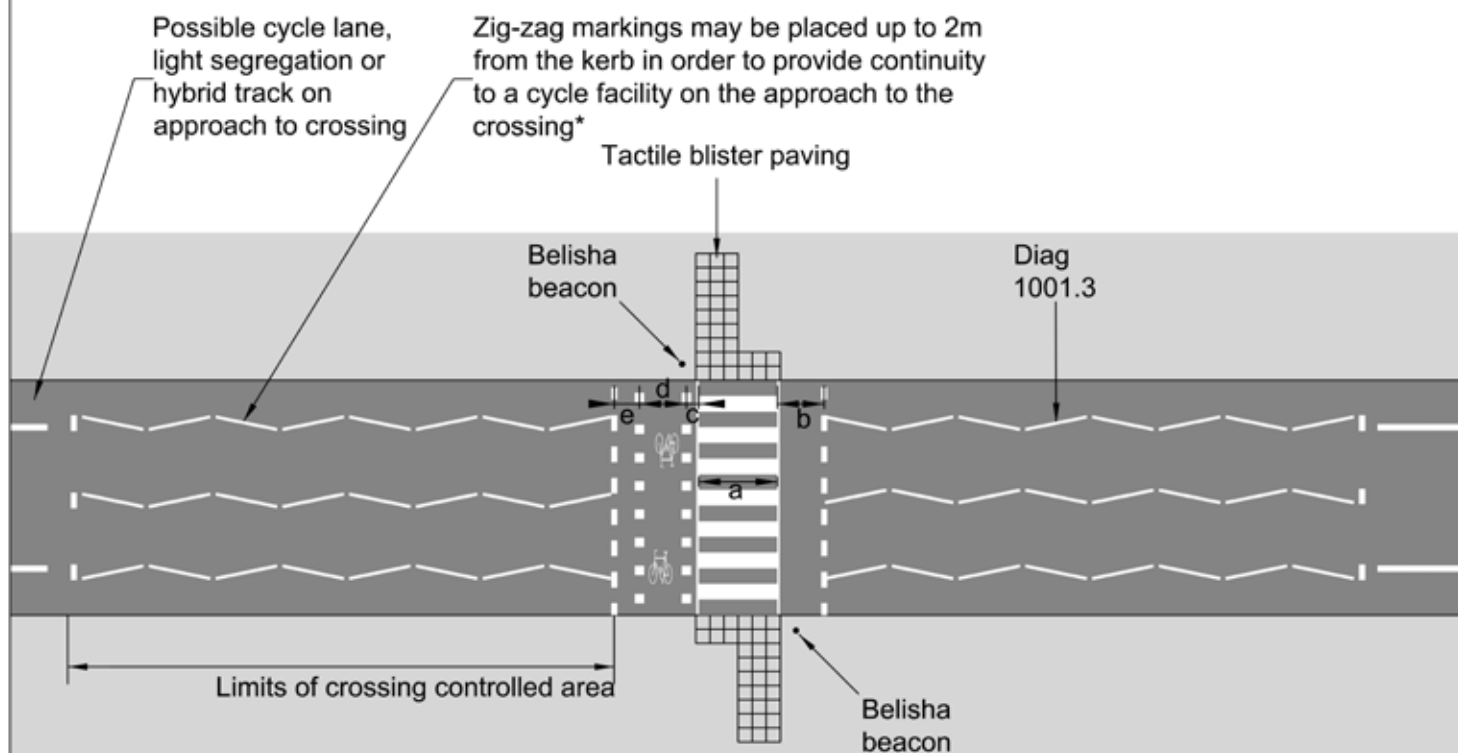
- a – Pedestrian crossing width 4m min, 10m max.
  - b – Distance of give way line to pedestrian crossing 1.1m min, 3m max.
  - c – Distance between pedestrian and cycle crossing 0.4m.
  - d – Cycle crossing width 1.5m min, 3.8m max.
  - e – Distance of give way line to cycle crossing 0.8m.
- Other Considerations

## Other considerations

- A blind person would not start to cross until sure that vehicles have stopped and would therefore seek a pedestrian controlled signal crossing. Other groups of pedestrians, including people with learning impairments and older people may feel safer and more comfortable using signalised crossings.
- Parallel crossings for pedestrians and cyclists are unsuitable in locations where the 85th percentile vehicle speed is greater than 35mph or where there would be regular congestion resulting from high vehicle or pedestrian flows.
- Where a crossing is used on a road of two lanes or more consideration should be given to whether a vehicle stopped in the nearside lane will obstruct visibility to a crossing pedestrian or cyclist from a vehicle in the off-side lane.
- Crossings may be divided by a refuge – see DE038.



# DE043 Parallel Crossing for Pedestrians & Cyclists



Llywodraeth Cymru  
Welsh Government

Last Revised

September 2014

Do Not Scale Drawing

Drawing Produced By: Arup, 4 Pierhead Street, Capital Waterside, Cardiff, CF10 4QP

Copyright: Welsh Government

# DE044 Puffin and Ped-X Crossings

## Measure and Brief Description

Puffin and Ped-X crossings are stand-alone signal-controlled pedestrian crossings. The traffic signal sequence is similar to a crossing facility at a signalised junction. Both types of crossing incorporate detection technology (usually infra-red which allows cancellation of the pedestrian demand if a pedestrian crosses after pressing the button but before the green man has activated. Additionally, the detectors are used to measure the speed at which pedestrians are crossing and automatically adjust the time allowed to cross the road. Puffin crossings have nearside pedestrian red and green aspects located as part of or above the push button unit, and located so that they can be seen at the same time as approaching traffic. A Ped-X crossing is a newer type, similar to a Puffin crossing in terms of signal sequence and detection, but with far side pedestrian signal aspects. 'Countdown' displays which show the time in seconds to the end of the crossing period, can be used with Ped-X crossings, but in this case, on-crossing detection cannot be used as the clearance period is fixed. Pelican crossings are an obsolescent type of crossing with a flashing amber for drivers and flashing green man crossing period, which must not be used for new installations.\*

## Benefits

- Signalled crossings are preferred by visually impaired people, people with learning impairments and other groups of pedestrians including older people.
- Puffin and Ped-X crossings include detector technology to extend the pedestrian crossing time so that people walking more slowly are not disadvantaged. Parallel pedestrian/cycle crossings provide relatively low-cost facilities which give an immediate response to pedestrians' and cyclists' need to cross.

## Key Design Features

- Ped-X crossings with farside pedestrian signals are preferred by some users and are more suited to busy locations where pedestrians may have difficulty seeing the nearside indicators due to crowding.
- Signal-controlled pedestrian crossings may either cross a full width carriageway in a single stage or comprise two crossings with a central refuge.
- Crossings of single carriageways should preferably be single stage crossings with rapid push button response and recall timings.
- Two stage crossings are often staggered to ensure that pedestrians treat each stage as a separate crossing, but straight-ahead divided crossings are much more convenient for pedestrians and should be used wherever possible. However, it will be important to avoid 'see-through' where pedestrians could mistake a green man on the far crossing for a green man on the near crossing.
- Two-stage straight ahead crossings can be achieved by using nearside pedestrian aspects, a wide central median or angling the crossings in preference to introducing a stagger.
- Where central waiting areas are created they should give maximum space and comfort to waiting users at peak times.
- The aim should be to minimise the time that pedestrians have to wait at a crossing. Where a crossing has two stages consideration should be given to including an advance call on the second crossing to minimise the time that a pedestrian has to wait for the second crossing.
- It is important that sufficient time is allocated to allow all pedestrians (particularly older people) to cross the road in an efficient unhurried manner.
- Crossings should reflect desire lines, using angled crossings if they are appropriate.
- Tactile paving and rotating cones for visually impaired users to be provided.
- Audible signals should be considered but can be intrusive in residential areas.
- 8 zig zag markings are normally provided on either side of the crossing, which prevent parking, loading or overtaking. The maximum number is 18 and the minimum number is 2.
- Zig zag markings can be placed up to 2m from the kerbline so that space for cycling can be maintained up to the crossing.\* There should be adequate visibility to a crossing to ensure that approaching motorists can see a pedestrian or cyclist about to cross the road.

## Dimensions

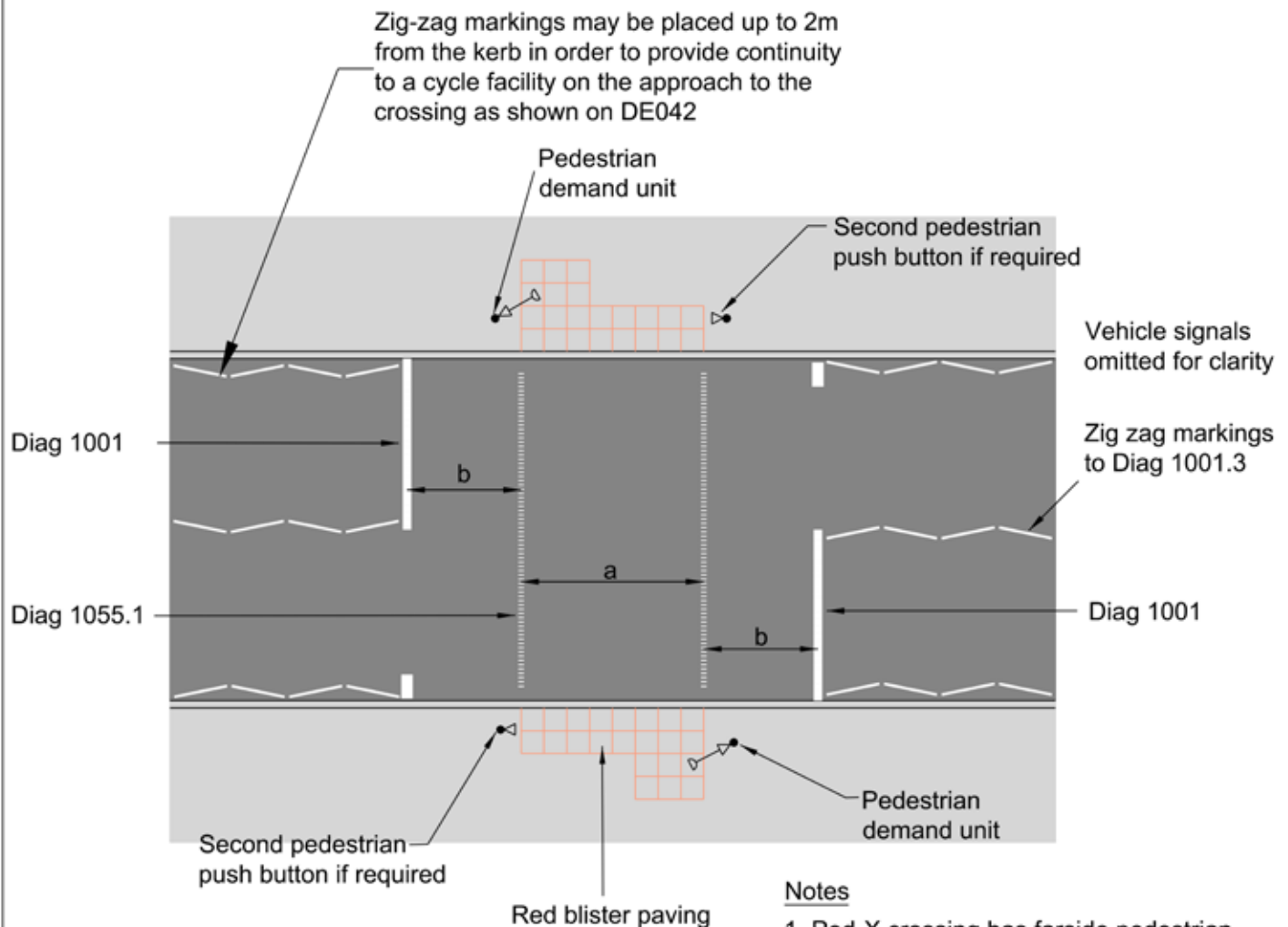
- a - Crossing width 2.4m min, 10m max.
- b - Distance of give way line to crossing studs 1.7m min, 3m max. a – Pedestrian crossing width 4m min, 10m max.

## Other considerations

- Signal controlled crossings should generally be at least 20 metres from a side road junction.
- On the approach to or exit from a roundabout a non-staggered signal-controlled crossing should be sited either at 20 metres or more than 60 metres from the give way line. If the crossing is staggered, the crossing of the entry arm may be located between 20 metres and 60 metres from the give way line.
- The topography of the site needs to be such that the pedestrian detectors will operate satisfactorily.
- Care should be taken when locating signalled pedestrian crossings in close proximity to give-way junctions, particularly roundabouts, where the presence of the vehicle signals could be misinterpreted as giving priority at the give-way junction.
- Crossing points should remain free from street furniture and other clutter.
- Signalised crossings should not be used where 85th percentile speeds exceed 50mph.

## Further References

- Department for Transport (2001) – Traffic Advisory Leaflet 1/01, Puffin Pedestrian Crossing.
- Department for Transport (2001) – Traffic Advisory Leaflet 1/02, The Installation of Puffin Pedestrian Crossings.
- Department for Transport (2005) – Traffic Advisory Leaflet 5/05, Pedestrian Facilities at Signal-Controlled Junctions.
- Department for Transport (1995) – LTN 2/95, The Design of Pedestrian Crossings.



#### Notes

1. Ped-X crossing has farside pedestrian aspects instead of nearside.

2. Ped-X with 'Countdown' crossing is as Ped-X, with countdown display next to nearside pedestrian aspects.



# DE045 Toucan Crossing

## Measure and Brief Description

A Toucan crossing is a stand-alone signal-controlled pedestrian and cycle crossing. The traffic signal sequence is similar to a crossing facility at a signalised junction. Toucan crossings incorporate detection technology (usually infra-red) which allows cancellation of the pedestrian/cycle demand if a person crosses after pressing the button but before the green man has activated. Additionally, the detectors are used to measure the speed at which people are crossing and automatically adjust the time allowed to cross the road. Toucan crossings have nearside pedestrian/cycle red and green aspects located as part of or above the push button unit and located so that they can be seen at the same time as approaching traffic; farside aspects can also be used if preferred. Toucan crossings are used where there is a significant demand for cycle crossing movements over busy and faster roads, and a priority crossing (DE037) or parallel crossing for pedestrians and cyclists (DE043)\* is not suitable.

## Benefits

- Toucans provide a compact crossing facility catering for both pedestrians and cyclists in one location
- Signalised crossings are preferred by visually impaired people, people with learning impairments and other groups of pedestrians including older people.
- Toucan crossings include detector technology to extend the pedestrian/cycle crossing time so that people travelling more slowly are not disadvantaged.

## Key Design Features

- Crossings with farside pedestrian/cycle signals are preferred by some users and are more suited to busy locations where people may have difficulty seeing the nearside indicators due to crowding.
- Toucan crossings may either cross a full width carriageway in a single stage or comprise two crossings with a central refuge.
- Crossings of single carriageways should preferably be single stage crossings with rapid push button response and recall timings.
- Where a Toucan crossing is required on a wide road, a single-stage crossing should generally be provided for widths below 15m. For widths over 15m, the option of a single-stage crossing should be fully considered in the light of existing examples.
- Staggered divided Toucan crossings very difficult for cyclists to use and should not normally be provided. Straight-ahead divided crossings are much more convenient for cyclists and should be used in preference. However, it will be important to avoid 'see-through' where users could mistake a green signal on the far crossing for a green signal on the near crossing.
- Two-stage straight ahead crossings can be achieved by using nearside pedestrian/cycle aspects, a wide central median or angling the crossings in preference to introducing a stagger.
- Where central waiting areas are created they should give maximum space and comfort to waiting users at peak times.
- The aim should be to minimise the time that pedestrians and cyclists have to wait at a crossing. Where a crossing has two stages consideration should be given to including an advance call on the second crossing to minimise the time that a pedestrian or cyclist has to wait for the second crossing.
- It is important that sufficient time is allocated to allow all pedestrians (particularly older people) to cross the road in an efficient unhurried manner.
- Designs should also take account of the demand for cyclists wishing to join or leave the carriageway at the crossing.
- Crossings should reflect desire lines, using angled crossings if they are appropriate.
- Tactile paving and rotating cones for visually impaired users to be provided.
- Audible signals should be considered but can be intrusive in residential areas.
- 8 zig zag markings are normally provided on either side of the crossing, which prevent parking, loading or overtaking. The maximum number is 18 and the minimum number is 2.
- Zig zag markings can be placed up to 2m from the kerblines so that space for cycling can be maintained up to the crossing.\*

## Dimensions

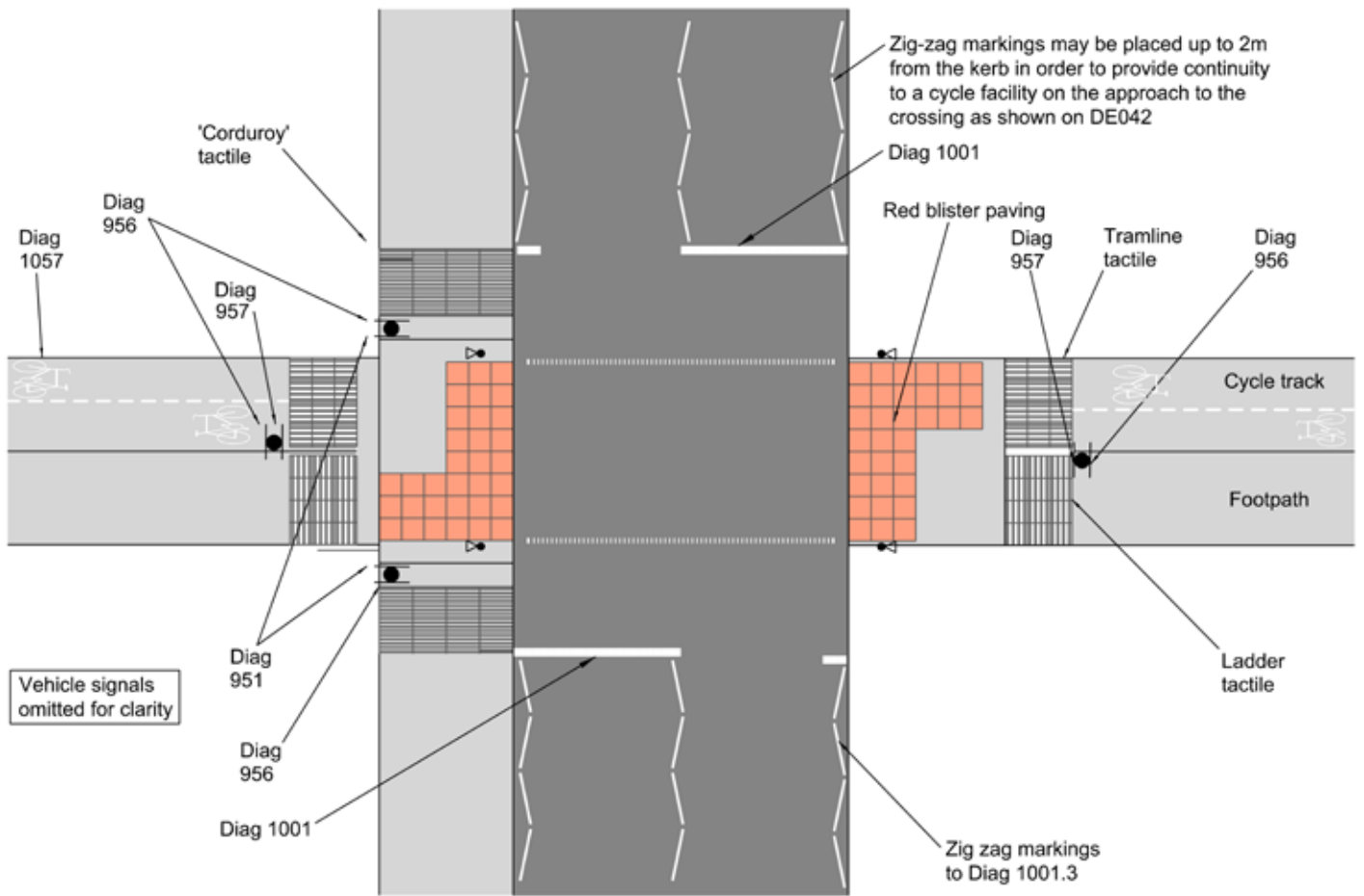
- a - Minimum recommended width of crossing is 4m, although where usage is low a 3m width is allowed. Maximum permitted width is 10m.
- b - Distance of stop line to crossing studs 1.7m min, 3m max. a - Crossing width 2.4m min, 10m max.

## Other considerations

- Signal controlled crossings should generally be at least 20 metres from a side road junction.
- On the approach to or exit from a roundabout a non-staggered signal-controlled crossing should be sited either at 20 metres or more than 60 metres from the give way line.
- When crossings are located close to a signal controlled junction, consideration should be given to linking the signals to the junction signals. The distance at which this should be considered will depend on traffic conditions but 100 metres is likely to be the minimum distance at which linking is required.
- The topography of the site needs to be such that the pedestrian detectors will operate satisfactorily.
- Toucans that have a long delay time before giving a green to cyclists cause frustration and can lead to frequent attempts to cross before the green light appears. Detection systems that identify approaching pedestrians and cyclists can speed up the countdown timer and reduce waiting times on the side of a busy or fast moving road.
- Crossing points should remain free from street furniture and other clutter.
- Signalised crossings should not be used where 85th percentile speeds exceed 50mph.

## Further References

- Department for Transport (2005) – Traffic Advisory Leaflet 5/05, Pedestrian Facilities at Signal-Controlled Junctions.
- Department for Transport (1995) – LTN 2/95, The Design of Pedestrian Crossings.



# DE046 Pedestrian/Cycle Bridge

## Measure and Brief Description

Bridges provide very useful connections for footpaths and cycle tracks, taking routes across barriers such as major roads without conflict, railways and waterways. Where the topography is favourable the need for approach ramps can be minimised. Achieving good natural surveillance is necessary to provide personal security. New bridges can be designed as features along a route and may become attractors in their own right. New bridges are generally considerably cheaper than new subways/underpasses.

## Benefits

- Provides a conflict-free crossing of a major barrier.
- A new bridge may provide an opportunity for a landmark feature.
- A bridge will often be cheaper than a subway/underpass.
- Better personal security than a subway/underpass.

## Key Design Features

- Bridges require considerable investment and should normally cater for both pedestrians and cyclists.
- Bridges can attract high numbers of pedestrians and cyclists and the aim should be to provide effective segregation between them so that each group can travel at their preferred speed.
- Bridge approaches and decks should be straight or nearly straight. Right angled turns are difficult for cyclists to negotiate.
- Gradients should be in accord with the maximum values given in Figure 4.4, depending on slope length. Steeper gradients than 7% are not recommended, except over very short distances.
- Where the topography is favourable the need for approach ramps can be minimised.
- See DE003 for Ramps, DE004 for Steps.

## Dimensions

a – Overall deck width:

- Pedestrian only: A minimum width of 2m, with additional width for busy routes – refer to Pedestrian Comfort Guidelines
- Unsegregated pedestrian/cycle bridge: the width should reflect the level and type of use forecast with a minimum of 4m width on primary cycle routes, or 3.5m on less busy secondary routes. On particularly heavily trafficked routes it should be increased to 5m.

b – Segregated pedestrian/cycle bridge, footway width:

- the width should reflect the level and type of use forecast with a minimum of 2m width, increasing to 3.5m width where there is frequent use by groups.

c – Segregated pedestrian/cycle bridge, cycle track width:

- Cycle track width should be sufficient to accommodate the forecast level of use with a minimum of:
  - » 3m where the peak hour flow is less than 50/hr;
  - » 4m on a primary cycle route (3.5m on a secondary cycle route) where it is 50-150/hr;
  - » 4.5m over 150/hr.

h - Parapet height

- Parapet height for new bridges is normally 1.15m for pedestrians, 1.4m for cyclists, 1.8m for equestrians.
- On existing structures being converted to cycle use this parapet height cannot always be achieved, but it should not necessarily preclude their use as crossings for cyclists. Further advice is given in Sustrans Technical Information Note 30 Parapet Heights on Cycle Routes.

## Other considerations

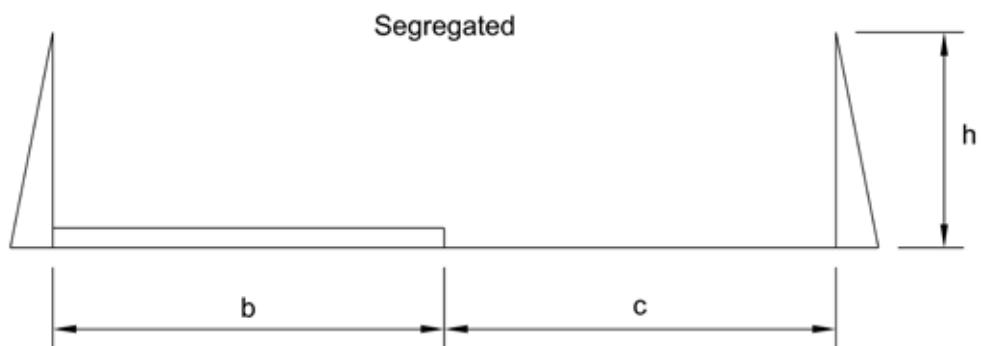
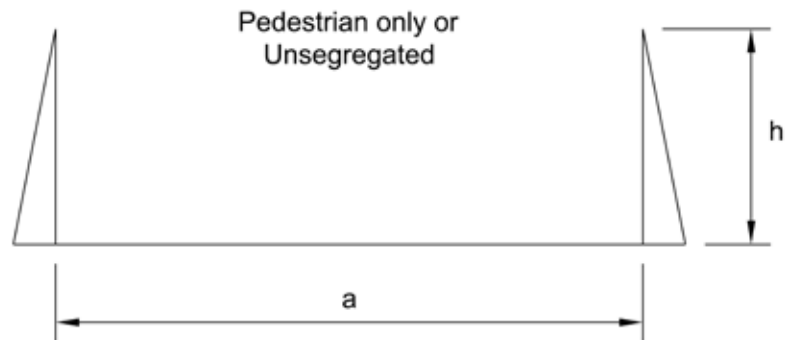
- Similar criteria apply to the conversion of footways over road bridges to shared use facilities Design widths should acknowledge suppressed demand and allow for growth in user numbers.
- Exposure of users to the weather should be considered – covered bridges will be beneficial.

## Further References

- Welsh Government (2004) - DMRB BD29/04, Design Criteria for Footbridges.

DE046

## Pedestrian/Cycle Bridge

Llywodraeth Cymru  
Welsh Government

Last Revised

September 2014

Do Not Scale Drawing

Drawing Produced By: Arup, 4 Pierhead Street, Capital Waterside, Cardiff, CF10 4QP

Copyright: Welsh Government



# DE047 Subway/Underpass

## Measure and Brief Description

Subways/underpasses can provide very useful connections for footpaths and cycle tracks, taking routes across barriers such as at major roads without conflict, railways and waterways. Where the topography is favourable the need for approach ramps can be minimised. Achieving good natural surveillance is necessary to provide personal security. This option may involve the conversion of an existing pedestrian subway or an underpass provided for private access.

## Benefits

- Provides a conflict free crossing of a major barrier.
- Avoids exposure to the weather.
- The longitudinal profile of an underpass (down then up) is more comfortable for cyclists than bridges with approach ramps.

## Key Design Features

- Subways/underpasses require considerable investment and should normally cater for both pedestrians and cyclists.
- Subways/underpasses can attract high numbers of pedestrians and cyclists and the aim should be to provide effective segregation between them so that each group can travel at their preferred speed.
- Approaches and the structures themselves should be straight or nearly straight. Right angled turns are difficult for cyclists to negotiate.
- Gradients should be in accord with the maximum values given in Figure 4.4, depending on slope length. Steeper gradients than 7% are not recommended, except over very short distances.
- Where the topography is favourable the need for approach ramps can be minimised.
- Lighting should be provided and be vandal proof.
- Corners and recesses should be avoided, with the exits being visible to users on entry.
- Natural lighting should be maximised by the use of generous widths, angled sides to the structure and light wells on longer crossings.
- See DE003 for Ramps, DE004 for Steps.

## Dimensions

- Subways for pedestrians require headroom (h1) of at least 2.3m (2.6m for lengths over 23m) and a width (w1) of 3m (2.3m for light use).
- Subways for use by cyclists require headroom (h1) of 2.4m (2.7m for lengths over 23m) and width (w1) of at least 4m (3m for light use) if unsegregated.
- Segregated: the width for pedestrians (w2) should be at least 2m, the cycle track (w3) 2.5m and the margin strip (w4) 0.5m. Headroom for cyclists (h2) and pedestrians (h3) as above.
- A headroom of 3.7m is required if the routes is to be used by mounted equestrians.

## Other considerations

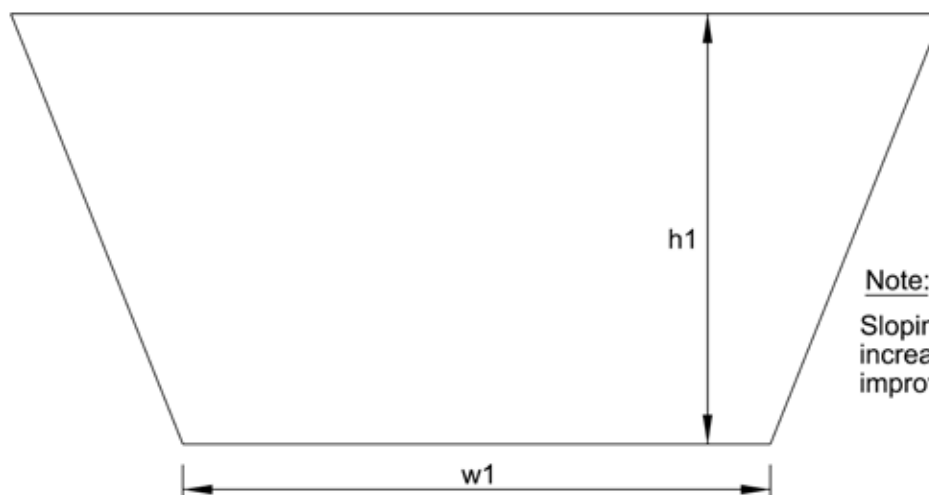
- The headroom in existing pedestrian subways is typically 2.3m; the slightly sub-standard height for cyclists should not lead to automatic rejection of a proposal to permit cycling. There are many examples of structures on public roads and on traffic free routes with headroom well below 2.4m, which operate without incident for cyclists. Any restricted headroom should be clearly signed. The 'cyclists dismount' sign should not be used.
- Exit must be visible on entering the subway.
- Generous headroom and width will be highly beneficial in terms of subjective safety, natural surveillance and personal security.
- Barriers to slow cyclists should not normally be used as these can restrict access for non-standard cycles.

## Further References

- Welsh Government (1993) - DMRB TD36/93, Subways for Pedestrians and Pedal Cyclists Layout and Dimensions.

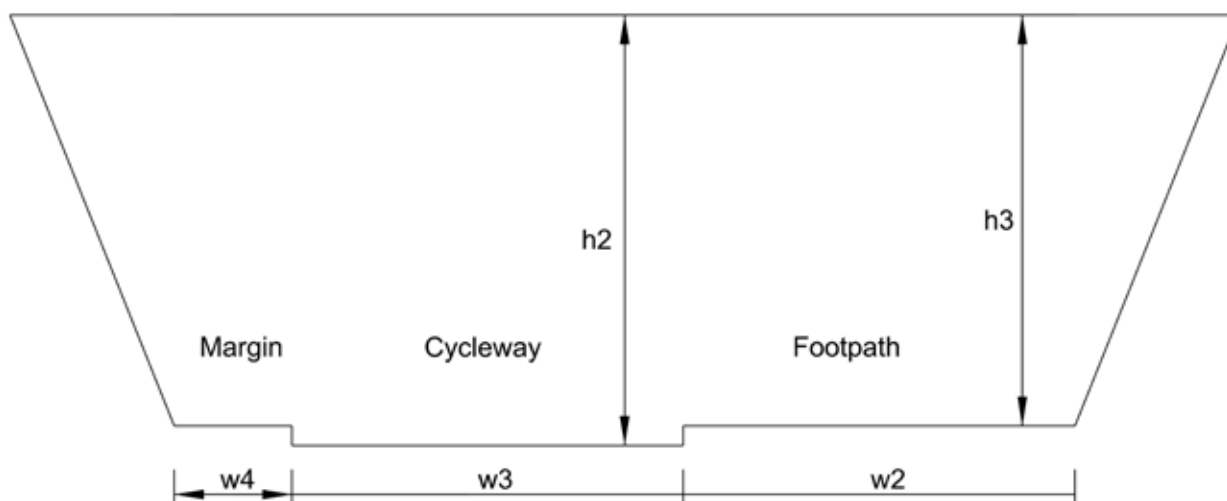
DE047

## Subway/Underpass

Note:

Sloping sides preferred to increase natural light and improve personal security

Pedestrian only or  
Unsegregated



Segregated



Llywodraeth Cymru  
Welsh Government

Last Revised

September 2014

Do Not Scale Drawing

Drawing Produced By: Arup, 4 Pierhead Street, Capital Waterside, Cardiff, CF10 4QP

Copyright: Welsh Government

# DE048 Wheeling Ramp

## Measure and Brief Description

Where cycle routes are introduced onto routes originally designed for pedestrian use only, such as canal towpaths or railway footbridges, flights of steps are sometimes unavoidable, at least in the short term. To assist cyclists, wheeling ramps should be added to the flights using steel sections or by forming them in concrete.

## Benefits

- Enables cyclists to negotiate an existing footbridge or underpass at minimal cost where a ramp is not possible.

## Key Design Features

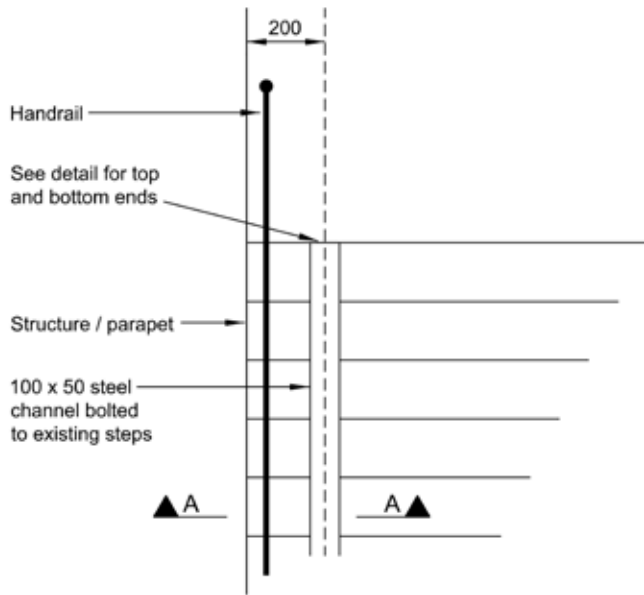
- Locating the wheeling ramp close to the wall minimises the trip hazard for pedestrians.
- The distance between the ramp and the wall should be enough to ensure that the pedals and handlebars do not clash with the wall or handrail while the bicycle is being held reasonably vertically.
- The wheeling channel needs to extend beyond the top and bottom steps to provide a smooth transition.
- Steel sections should have a nonslip surface so that the tyres grip the ramp on descent.
- In most cases the ramp is fitted to one side, usually on the right for people climbing, but on well used routes a ramp on each side may be considered.

## Dimensions

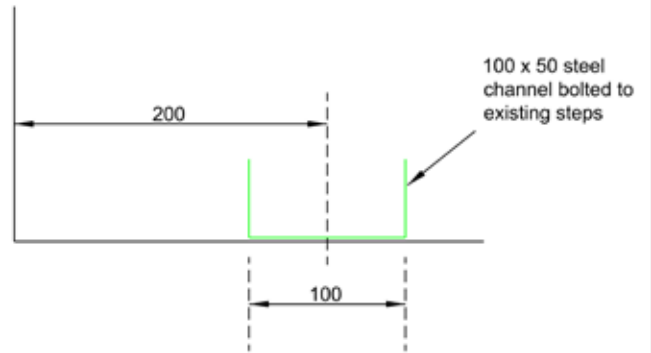
- A channel 100 mm wide and 50 mm deep is generally suitable.
- The centre of the channel should be 200mm from the side wall.

## Other considerations

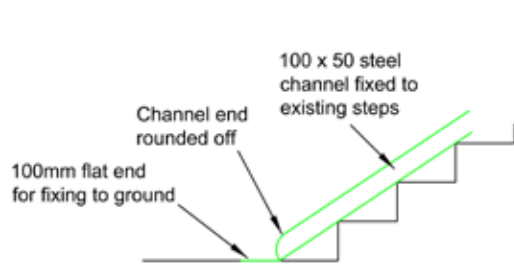
- Wheeling ramps should not obstruct convenient access to the handrail nor be located in the centre of the steps where they might form a trip hazard.
- Where a ramp is constructed in metal, a continuous piece is preferred.
- In some instances timber and stone surfaces blend better with the original construction.
- Requires considerable effort from cyclists, especially with luggage.
- Are of no benefit to many non-standard cycles such as tricycles, cargo bikes and cycles with trailers.



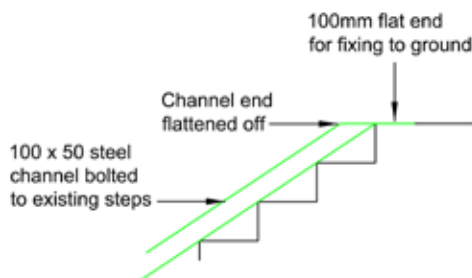
Elevation



Section A - A



Bottom end detail



Top end detail



# DE049 Unmarked Informal Junction

## Measure and Brief Description

Junctions in urban areas, even on relatively busy routes, can be designed without defined priority, requiring all road users to slow down and engage/negotiate with other road users. The application of these 'shared space' principles is becoming increasingly common and has been demonstrated to be effective in terms of traffic capacity and safety on four-arm junctions with peak period flows in excess of 2,500 vehicles per hour. Examples include junctions in the centre of Coventry, in Poynton in Cheshire and in Hackney (see photos). This type of junction can work well for pedestrians and cyclists.

## Benefits

- Reduced delays to all users, particularly during off-peak periods
- Good safety record
- Improved public realm, enhancing the attractiveness of urban centres

## Key Design Features

- Junctions of this type should be designed to suit local circumstances – standardised solutions are not appropriate.
- Motor vehicle paths should be limited to a single lane on entries and exits.
- General lane widths should be kept as narrow as possible but separate provision may be made for cyclists so that they are able to pass queuing vehicles on the junction approaches.
- Speeds on the approaches should be around 20mph.
- Traffic signal crossings should not be used on the approaches to the junction since green signals can reinforce drivers' sense of priority over pedestrians.
- Informal (or zebra/parallel pedestrian and cycle crossings) should be provided on desire lines.
- Crossings can also be made available to cyclists so that they can travel around the junction via cycle tracks or shared paths outside the carriageway.
- Crossings should be paved in a material which contrasts with the general carriageway, with tactile paving.
- Central islands or median strips at crossings help pedestrians and cyclists to cross and make it more likely that drivers will cede priority (see DE038 and DE041).
- Paving materials that are visibly different from standard bituminous surfacing will help to reinforce the distinctiveness of the place.
- A range of kerb heights can be used between crossing points. Flush or very low kerbs will require tactile paving.

## Dimensions

- Overall dimensions vary but are typically around 25m to 40m across.

## Other considerations

- This type of junction works best in urban areas with high numbers of pedestrians and general activity, particularly town and city centres.
- They can form part of a wider public realm/shared space scheme, but can also be provided in isolation.
- Visually impaired people will prefer signalised crossings to zebra and informal crossings.

DE049

## Unmarked Informal Junction



Poynton, Cheshire - Double Junction, each designed to encourage circulatory priority, with courtesy crossings, carrying circa 26,000 vehicles per day overall



Leonard Circus, London - Uncontrolled junction with no designated crossings



Coventry - Plain uncontrolled junction with crossings



Llywodraeth Cymru  
Welsh Government

Last Revised

September 2014

Do Not Scale Drawing

Drawing Produced By: Arup, 4 Pierhead Street, Capital Waterside, Cardiff, CF10 4QP

Copyright: Welsh Government

# DE050 Advanced Stop Line

## Measure and Brief Description

An Advanced Stop Line (ASL) enables cyclists to take up an appropriate position in the 'reservoir', or waiting area between the two stop lines, for their intended manoeuvre ahead of general traffic, before the signals change to green. A cycle feeder lane should normally be provided, which will enable cyclists to pass queuing motor traffic on the approach to the stop line. They are established practice in most highway authorities and some now have a presumption to install ASLs at all signalled junctions. ASLs may not resolve all problems for cyclists at traffic signals however; they are of no value when signals are on green, and so may be less suitable on junction approaches which run during most of a signal cycle. A large, complex, high speed motor vehicle-dominated junction will not be made cycle-friendly by the provision of ASLs.

## Benefits

- Feeder lanes allow cyclists to bypass waiting traffic, and get to the ASL reservoir at the head of the queue. Cyclists can position themselves where they are visible and in the correct turning lane. This is particularly helpful for cyclists making right turns and where there is a separately signalled left turn and cyclists wait to go ahead.
- ASLs can be used to a safe area for a cyclist to merge back into the carriageway from a cycle track.
- The ASL reservoir provides cyclists with an area free from exhaust fumes in which to wait.
- ASLs improve the comfort of pedestrians, by setting waiting motor traffic back from the pedestrian crossing.

## Key Design Features

- The design of ASLs must be site-specific. Consideration should be given to factors such as the turning traffic volumes and dominant cycle movements, signal staging, location and number of approach lanes, and vehicle swept paths.
- Feeder lanes should be provided wherever possible and should preferably be mandatory, although a wide advisory cycle lane, accepting that some vehicles may encroach, may be better than a narrow mandatory lane.
- ASLs can also operate without feeder lanes, with 'gate' markings to diagram 1001.2A, but the benefit of an ASL is much reduced if no lead in lane is provided, since less confident cyclists will not try to reach the reservoir.
- Feeder lanes are normally located on the nearside. Centre and offside feeder lanes can also be provided to help cyclists make specific movements. For example where there is a heavy left-turning traffic movement which conflicts with a dominant ahead or right cycle movement, the feeder lane should be positioned between the left and ahead traffic lanes.
- Feeder lanes between traffic lanes need to be wider and this is generally achievable by narrowing the traffic lanes. Continuity of cycle lanes feeding ASLs should be maintained, with traffic having to cross the cycle lane to access the left turn lane.
- On approaches to ASLs, it is important that detection loops are positioned so that they cover the approach cycle lanes as well as the general traffic lanes. Often this is not the case, resulting in approaching cyclists not being detected. Similar considerations apply to above ground detection.
- Advanced stop lines can be partial width or have staggered stop lines\*. This is useful where right turns are not permitted (for cyclists or all vehicles), there are multiple right-turning lanes or tracking of vehicle movements into the arm of the junction shows that they would encroach on the ASL reservoir if it were full-width. There is some evidence that drivers less likely to encroach into partial ASLs.
- Coloured surfacing can also be used to emphasise the reservoir, which can be full or part width.

## Dimensions

- The recommended minimum length of the reservoir for cyclists is 5.0m - TSRGD permits a minimum of 4.0m. Longer reservoirs may be considered to satisfy demand, up to a maximum of 7.5m.\*
- Nearside feeder lanes should normally be a minimum of 1.5m wide, and wider where possible. The absolute minimum width is 1.2m.
- Central and offside feeder lanes should be a minimum of 2m wide – absolute minimum 1.5m.
- General traffic lanes may be reduced to a minimum of 2.5m, which allows motor traffic not to block or encroach on the cycle lane.

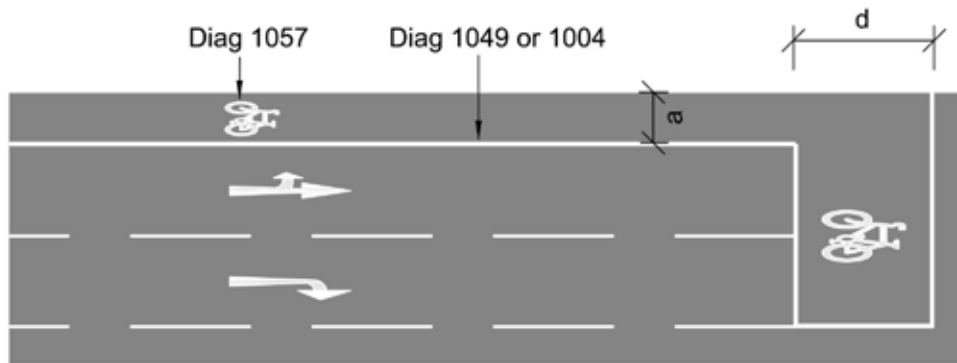
## Other considerations

- An 'early start' signal phase for cyclists can be used, using a low level cycle signal (primary) and/or a 4th aspect 'cycle filter'\* (primary or secondary). It enables cyclists waiting in the reservoir to start (typically up to 7 seconds) ahead of other traffic and to clear locations of potential conflict with traffic on the same arm (e.g. overtaking and turning left) or opposing traffic streams.
- ASLs have little or no effect on capacity if the number of all-purpose traffic lanes remains unaltered.
- Care should also be taken at signals where there are large numbers of HGVs turning left because of the potential for cyclists to move into the driver's blind spot.

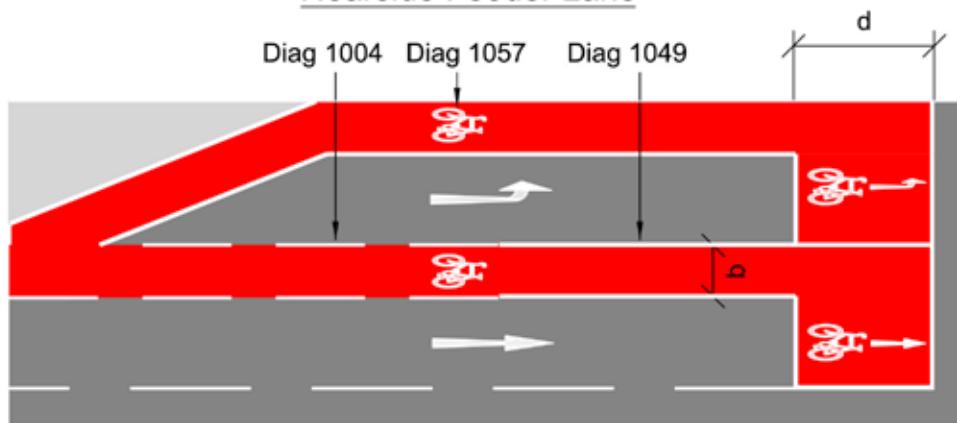
## Further References

- Department for Transport (2003) – Traffic Signs Manual

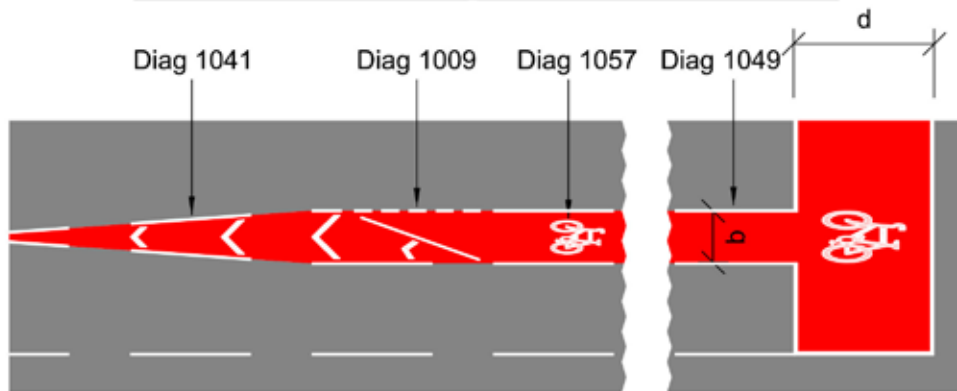




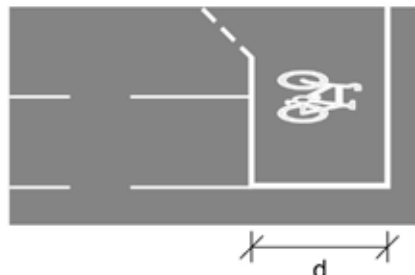
Nearside Feeder Lane



Nearside Lane Leading to Central Feeder Lane



Central Feeder Lane



Gate Feeder

Note - split ASLs and direction arrows not permitted without authorisation until revised TSRGD published



# DE051 Cycle Bypass at Traffic Signals

## Measure and Brief Description

Where space and level of pedestrian use allow, it will be beneficial to cyclists to provide a slip off in advance of a signalised junction, leading to a short section of cycle track that enables the cyclist to bypass the red signal. This may be used to assist cyclists either to turn left or to continue straight ahead at the top of a T junction. Cycle bypasses can also be used as approach routes to cycle and pedestrian crossings in order to facilitate difficult manoeuvres (e.g. right turns) or to make manoeuvres which are prohibited to other traffic.

## Benefits

- reduce delays to cyclists and offer time advantages compared to other traffic.
- formalise (and legalise) common cyclist behaviour.
- enable cyclists to maintain momentum, improving comfort.
- increases permeability where it enables cyclists to make manoeuvres that are prohibited for other modes.

## Key Design Features

- Bypasses should be built within the carriageway so as not to impede pedestrian flows, but where this is impractical the bypass can be merged into a cycle track at or close to footway level.
- The design should make it clear if the facility is to be used in one or both directions.
- Cycle bypasses may, or may not, have their own set of signals phased to give early starts, or separate cycle phases. They may simply end at a Give Way line, discharge into a lane or track, or merge into general traffic.
- Loop detection on the approaches, and infra-red technology to detect waiting cyclists will help to speed up sequencing of traffic signals ahead.
- Careful design is required at pedestrian crossing locations.

## Dimensions

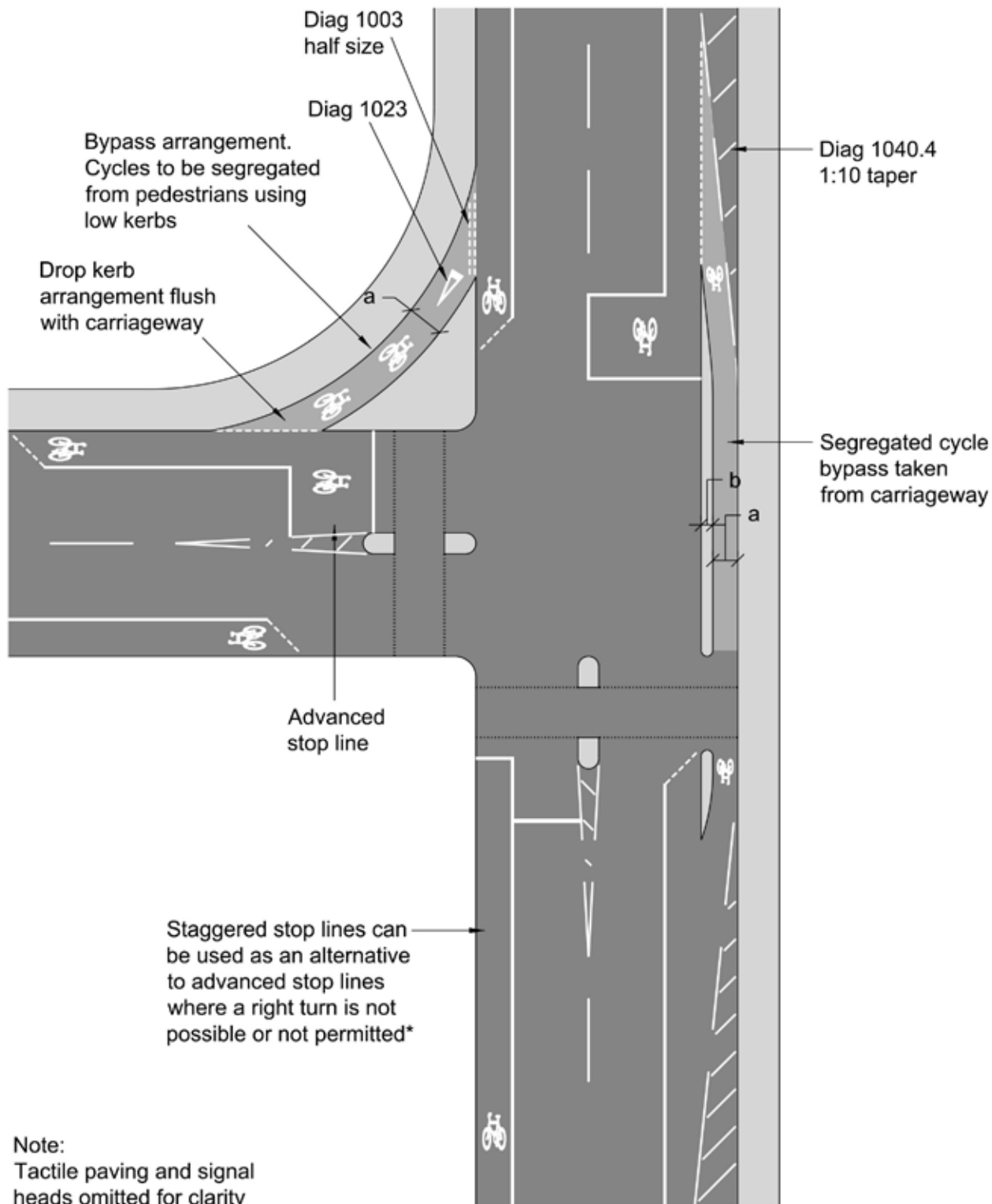
- Minimum 2.0m wide track (a), 1.5m for short lengths.
- Margin strip (b) min 0.5m.

## Other considerations

- Bypasses need to be designed to accommodate a variety of cycle types, and also be accessible to mini road sweepers. Poorly-accessible facilities will collect litter/broken glass and become unusable.
- A protected entry to the carriageway is preferred.

DE051

# Cycle Bypass at Traffic Signals



Llywodraeth Cymru  
Welsh Government

Last Revised

September 2014

Do Not Scale Drawing

Drawing Produced By: Arup, 4 Pierhead Street, Capital Waterside, Cardiff, CF10 4QP

Copyright: Welsh Government

# DE052 Cycle Lanes Through Signalised Junction

## Measure and Brief Description

A cycle lane marked through a signalised junction provides a visible indication of route continuity and increases drivers' awareness of key cycle movements. They are used to indicate route continuity and protect space for cyclist desire lines through major junctions on cycle routes.

## Benefits

- Help to guide cyclists.
- Raise the awareness of motorists that a junction forms part of a recognised cycle route.
- They are particularly beneficial for large and complex junctions.

## Key Design Features

- Route markings should comprise Diag 1010 markings\* or alternatively advisory cycle lane markings (diag 1004).
- Consider highlighting with coloured surfacing.

## Dimensions

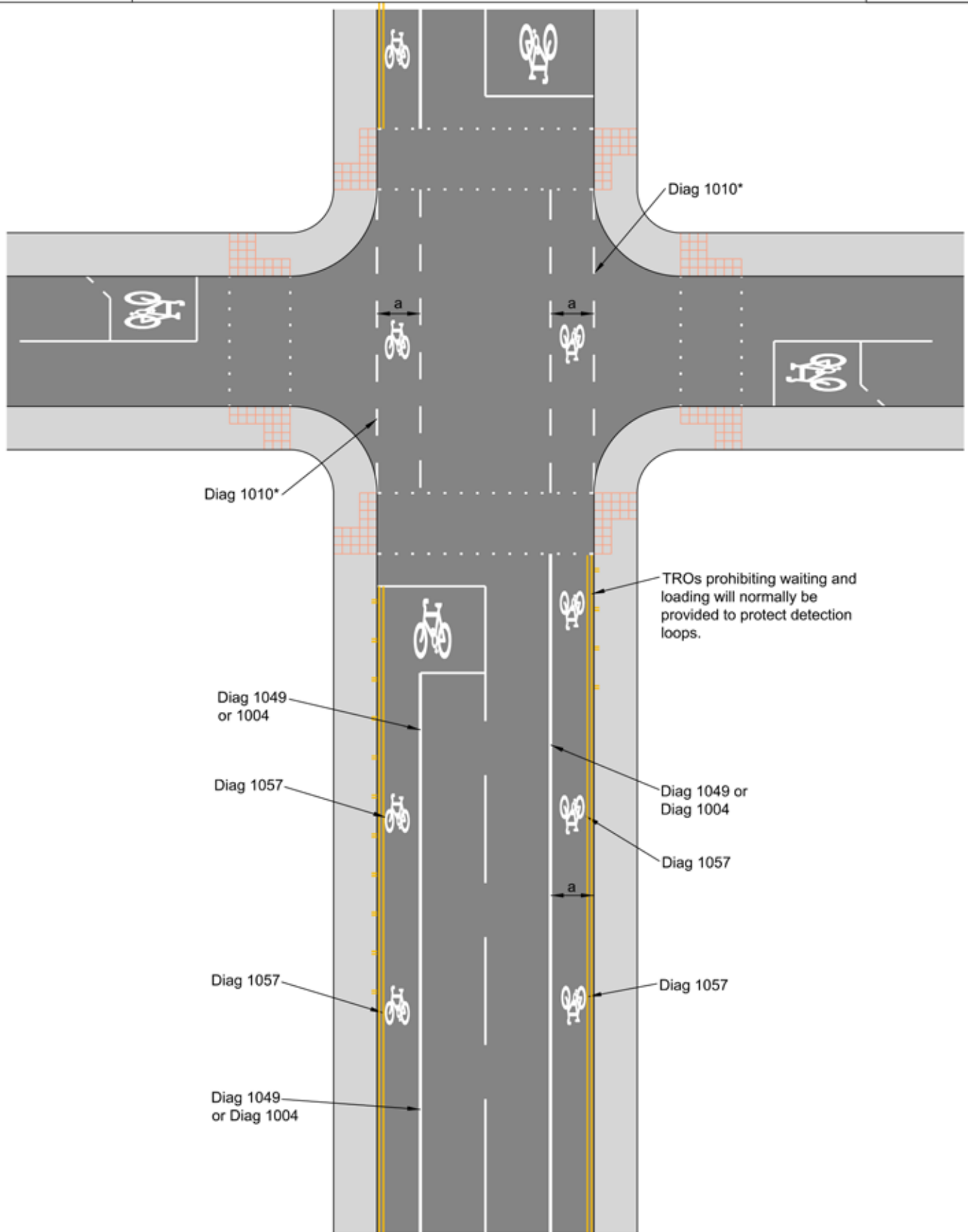
- a - Width of cycle lane on approaches refer to DE013 and DE014.
- b - Width of cycle lane through junction to be at least 0.5m wider than the approach cycle lane, min 2m is recommended where movements are generally straight ahead, and traffic passes cyclists on the riders' right.
- Minimum width lanes of 2.5m are recommended where traffic can be moving on both sides of the cyclist.

## Other considerations

- Where cyclists have several cross cutting desire lines through a junction, attempting to mark these may be confusing and counter-productive.
- Route markings through junctions will be subject to high levels of wear and will require maintenance.

DE052

# Cycle Lanes through Signalised Junction



Llywodraeth Cymru  
Welsh Government

Last Revised

September 2014

Do Not Scale Drawing

Drawing Produced By: Arup, 4 Pierhead Street, Capital Waterside, Cardiff, CF10 4QP

Copyright: Welsh Government

# DE053 Two Stage Right Turn at Traffic Signals

## Measure and Brief Description

Based on a standard feature at junctions in Denmark and other countries, this design provides for cyclists turning right at a multi-lane approach to a signalised junction, where the speed and volume of motor traffic makes the execution of a conventional right turn hazardous and unpleasant, even when an ASL is provided. Provision is made for cyclists to pull in to the side road on their left and wait there until the side road has a green light, at which point cyclists can make a straight across movement to complete their right turn.

## Benefits

- Cyclists able to make a safe right turn off a busy road, without having to weave across traffic lanes.

## Key Design Features

- The waiting area can be marked with a cycle symbol (Diag 1057) and right turn arrow (Diag 1059), backed with coloured surfacing if needed.
- The waiting area must be clear of any pedestrian crossing on the side road and sufficiently far back from ahead traffic on the main road for cyclists waiting there to feel safe. It should be clear of any cycle lane across the junction.
- Waiting area should be of sufficient size for the number of cyclists waiting to turn.
- Cyclists rely on the secondary signal on the side road to know when they can make the second stage of the turn, so this must be located where cyclists can see it.

## Dimensions

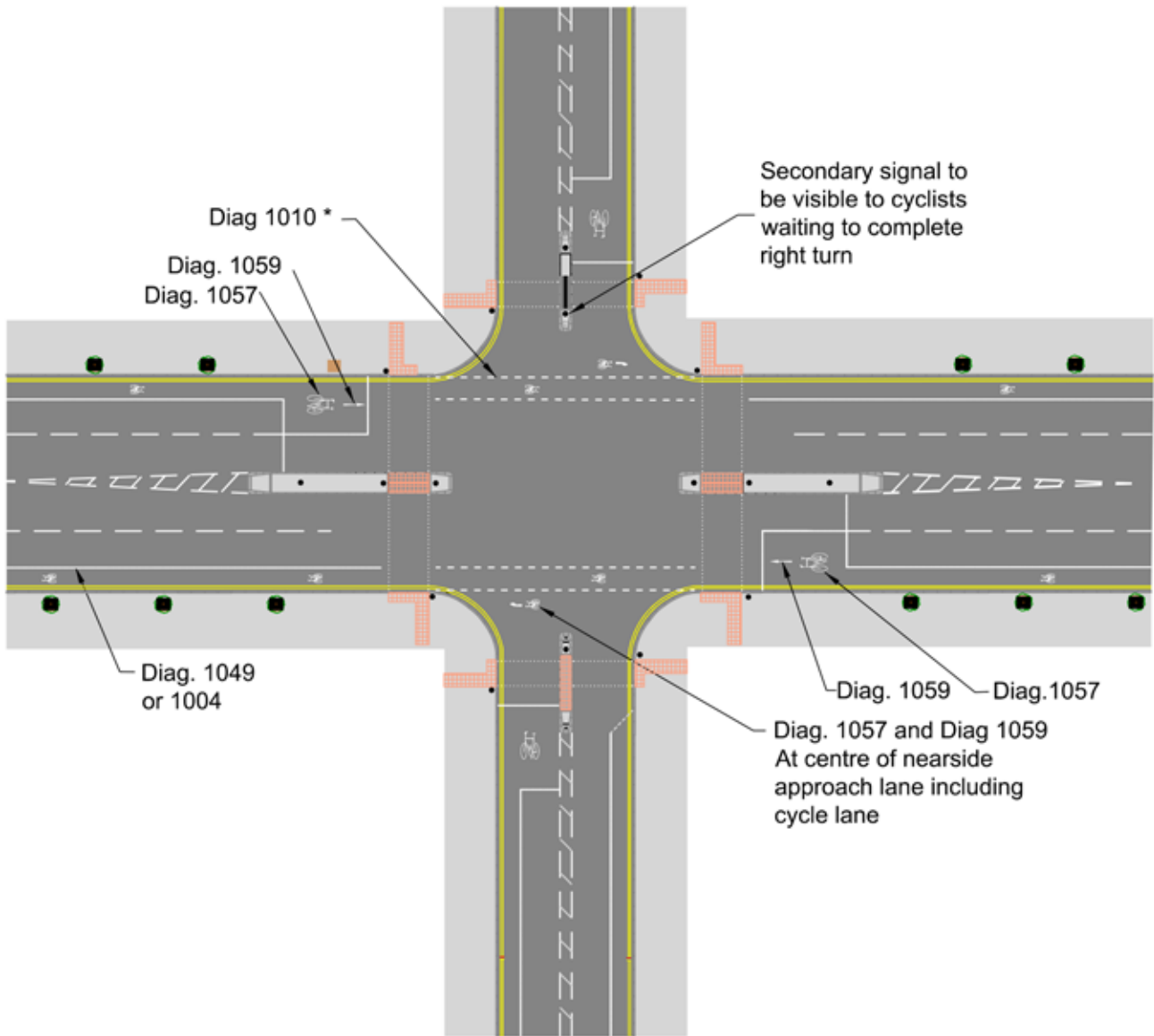
- Waiting area to be marked at centre of nearside approach lane.

## Other considerations

- Detection of waiting cycles will be necessary if the side road flow is insufficient to call the stage.
- Cyclists can choose to make a two stage right turn at junctions where such provision is not marked.
- An 'early start' signal phase for cyclists using low level signals/4th aspect cycle filter can be used to reduce conflict with left turning traffic – see DE050\*.
- This is an unfamiliar manoeuvre to most UK cyclists and a public information programme should be considered.
- Surface markings at junctions will be subject to high levels of wear and will require maintenance.

DE053

Two Stage Right Turn at Traffic Signals



Llywodraeth Cymru  
Welsh Government

Last Revised

September 2014

Do Not Scale Drawing

Drawing Produced By: Arup, 4 Pierhead Street, Capital Waterside, Cardiff, CF10 4QP

Copyright: Welsh Government



# DE054 Mini Roundabout

## Measure and Brief Description

Mini roundabouts with an inscribed circle diameter not greater than 15m, can be good alternatives to retaining priority junctions when traffic volumes are relatively low and speeds are slow. By providing tighter radii they contribute to achieving slower vehicle speeds, and can be included in traffic calming schemes. Single lane approaches mean that cyclists and motor vehicles pass through the roundabout in a single stream. They can be a compact and low cost solution to improving junction capacity where traffic signals are not preferred.

## Benefits

- Single circulatory carriageway puts cyclists in drivers' line of sight.
- Traffic calming effect, especially where they are installed on raised tables.
- Slower speeds which aids cyclists' comfort and safety, especially those wanting to turn right.
- Potential reduction in traffic delay compared to priority junctions.

## Key Design Features

- Single lane entries and exits.
- Domed central roundel.
- Deflection of traffic.
- Any cycle lanes on approaches should end 20-30m in advance of the give way line so that cyclists mix with traffic on the junction approach.

## Dimensions

- Outer radius (R1) 5m-7.5m.
- Radius of central roundel (R2) 0.5m -2m.

## Other considerations

- Consider incorporating a raised table.
- Consider incorporating deflector islands.
- Busier four arm and combinations of double roundabouts can be uncomfortable and less safe from a cyclist's perspective.
- The impact upon and the ability of pedestrians to cross the carriageway.
- Impact on long vehicles and buses may be an issue.

## Further References


- Welsh Government (1993) - DMRB TD 54/07, Design of Mini-Roundabouts

DE054


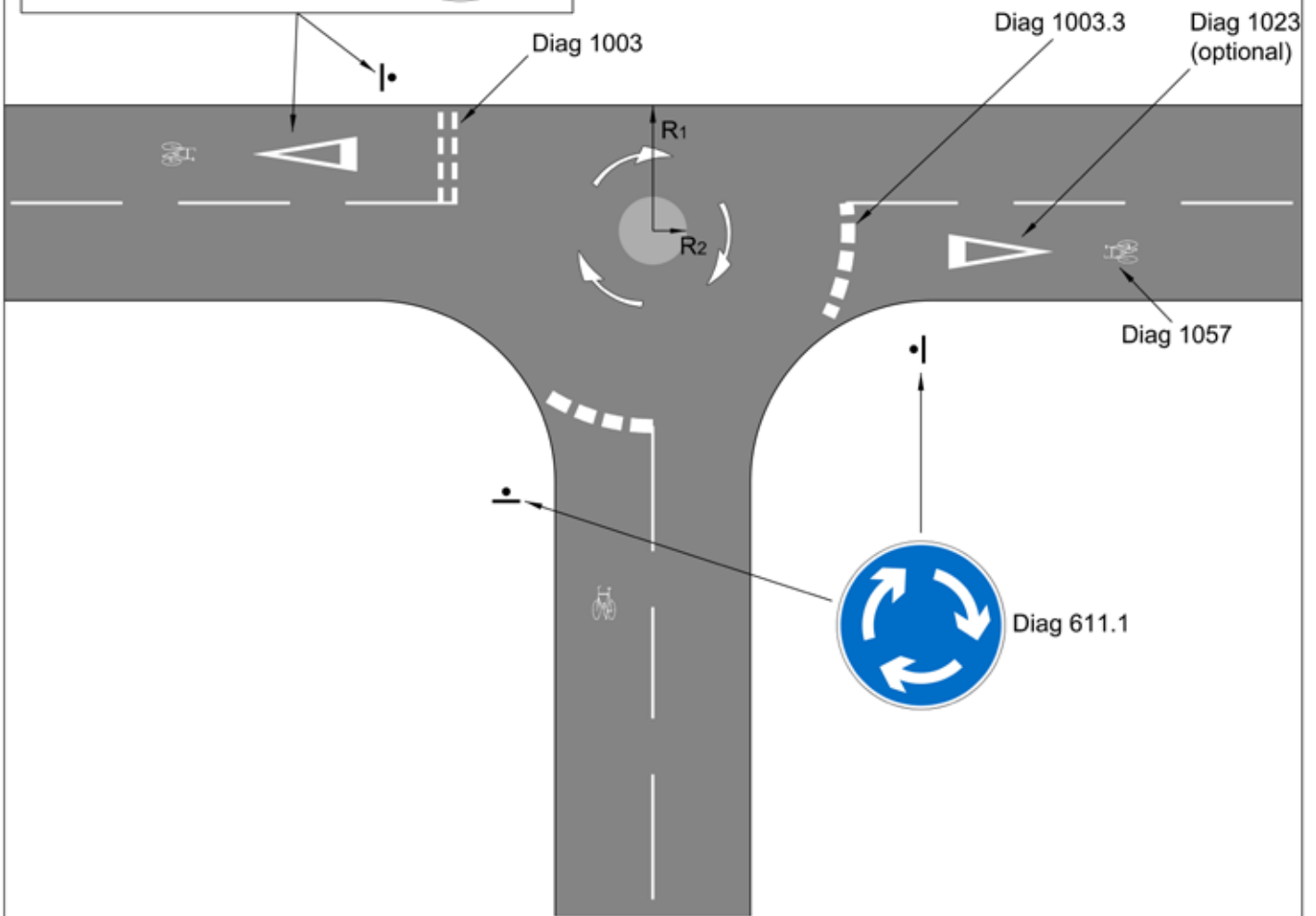
Mini Roundabout



Diag 602 and optional 1023 where deflection on approach is limited, with Diag 1003 give way marking



Diag 611.1

Last Revised	September 2014
Do Not Scale Drawing	
Drawing Produced By: Arup, 4 Pierhead Street, Capital Waterside, Cardiff, CF10 4QP	
Copyright: Welsh Government	

# DE055 Compact (“Continental”) Roundabout

## Measure and Brief Description

Compact roundabouts (also known as “continental” roundabouts) have tighter geometry that is more cycle friendly than typical UK roundabouts, which often have wide entries and exits. As the geometry encourages lower speeds, cyclists can pass through the roundabout in the same stream as other traffic. Drivers are unlikely to attempt to overtake cyclists on the circulatory carriageway because of its limited width. These roundabouts have arms that are aligned in a radial pattern, with unflared, single lane entries and exits, and a single lane circulatory carriageway. Deflection is therefore greater than normal UK practice, and the layout operates as a speed reducing feature. This design of roundabout is more common in mainland Europe, but the design principles can also be applied in the UK.

## Benefits

- Single circulatory carriageway puts cyclists in drivers’ line of sight.
- Tighter geometry at entry, circulatory carriageway and exit results in slower vehicle speeds.
- Slower speeds which aids cyclists’ comfort and safety, especially those wanting to turn right.

## Key Design Features

- Perpendicular entry and exit arms.
- Single lane entries, circulatory carriageway and exit.
- Any cycle lanes on approaches should end 20-30m in advance of the give way line so that cyclists mix with other traffic on the junction approach.

## Dimensions

- R1 - Outer radius of Inscribed Circle 10m-20m.
- R2 - Radius of over-run area 6.5m-15m.
- B1 - Width of over-run area 1m-1.5m.
- B2 - Width of circulatory carriageway 4.5m-6m.
- E1 - Entry radius 12m max.
- E2 - Exit radius 15m max.

## Other considerations

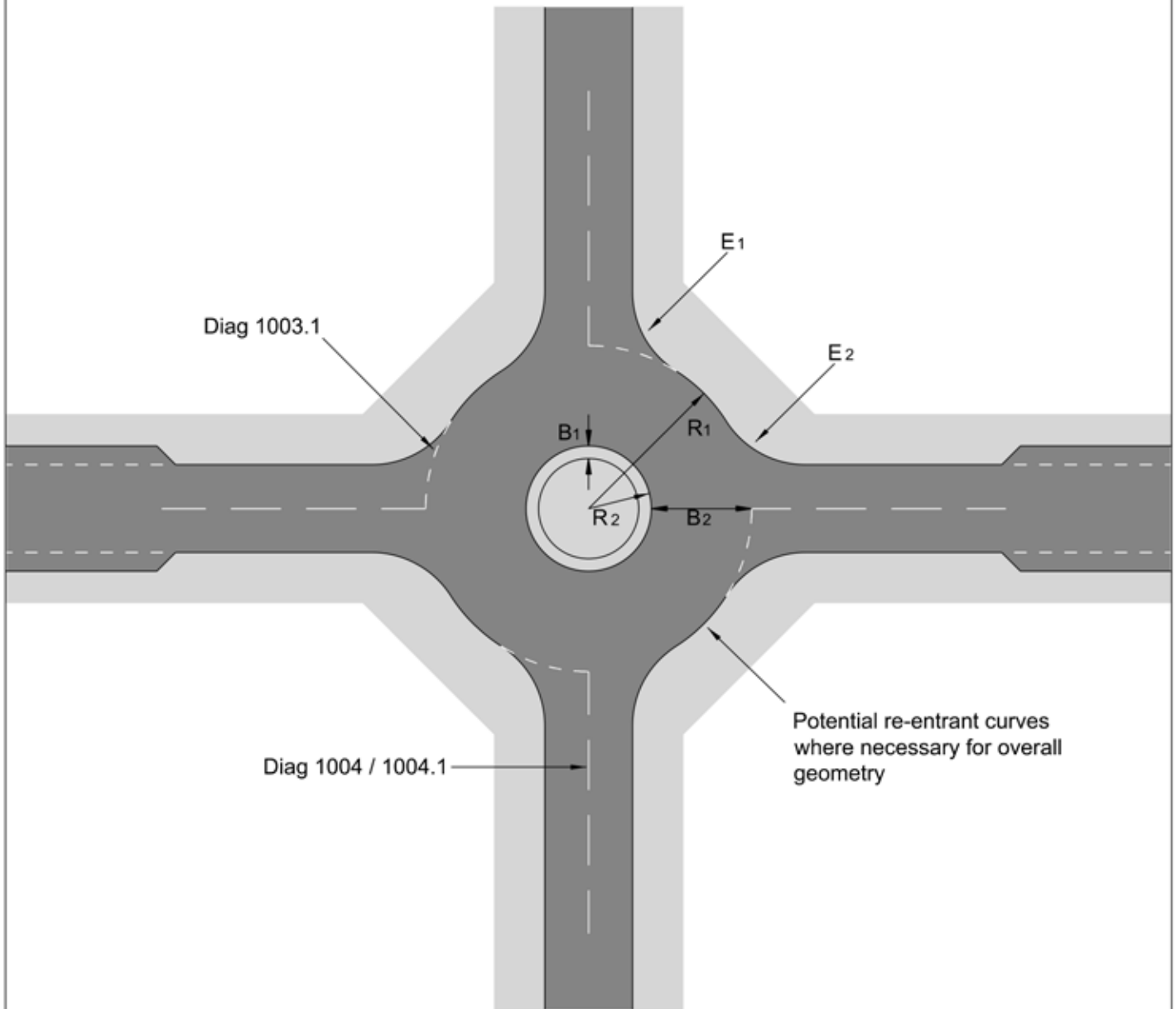
- Suitable for speed limits up to 40mph
- Roundabout capacity is typically approx. 25,000 AADT, but Dutch guidance is that above 6,000 AADT a separate cycle track should be provided. This guidance recommends that where the roundabout carries over 8,000 AADT consideration should be given to providing off-carriageway tracks for cyclists.
- Depending on layout, overall junction size and swept path requirements, it may be necessary for the roundabout to have ‘re-entrant’ kerblines on the outside edge of the circulatory carriageway to maintain tight entries and exits.
- Where a peripheral cycle track is appropriate, the aim should be to include cycle priority on each arm.
- Clutter-free (eg guardrailing) median islands on the junction arms will act as refuges for pedestrian and cyclist crossing movements and improve visibility and the streetscene.
- Zebra, parallel pedestrian/cycle\* or informal crossings can be placed close to the give way lines on direct desire lines.
- Street lighting must be provided.

## Further References

- Department for Transport (1997) – Traffic Advisory Leaflet 9/97, Cyclists at Roundabouts – Continental Design Geometry.
- Welsh Government (2007) - DMRB TD16/07, Geometric Design of Roundabouts.

DE055

## Compact ("Continental") Roundabout



Llywodraeth Cymru  
Welsh Government

Last Revised

September 2014

Do Not Scale Drawing

Drawing Produced By: Arup, 4 Pierhead Street, Capital Waterside, Cardiff, CF10 4QP

Copyright: Welsh Government





Llywodraeth Cymru  
Welsh Government

# Appendix B

## Walking Route Audit Tool



# Walking Route Audit Tool – Guidance notes

This tool has been developed to assist local authorities in the auditing of walking routes.

The tool can be used for both existing and proposed routes.

- On existing routes the current conditions should be audited.
- On proposed routes the proposed schemes should be audited.

## Scoring

The tool as shown in the table on p.384, requires the auditor to score the route against each of the factors using the following scale:

- 0 for poor provision,
- 1 for provision which is adequate but should be improved if possible
- 2 for good quality provision

Any route which scores less than 28 (out of a potential 40 points, ie a score of 70%) will require further improvement before it is included in the Existing or Integrated Network Maps. This threshold will be kept under review in the light of experience.

## Comments

As the scoring is sometimes qualitative the tool also allows the auditor to add comments explaining their score allocation.

For example where a route has scored 1 for Gradient, it may be useful to explain that although there is a steep uphill chapter there is a path which climbs the side of the valley in gentle steps, thereby allowing the cyclist to comfortably use the route.

The addition of text allows the audit scoring to be better understood when reviewed by other stakeholders.

## Actions

There is an additional column for Actions. This allows auditors to record any solutions to any of the issues identified on the route e.g. narrowing a junction mouth to reduce speeds or removing redundant street clutter along a chapter of the route to improve its attractiveness.

The assessment relies on an understanding of the route type (ie primary route, secondary route or local route) to be provided for as well as a



full understanding of the existing traffic conditions (i.e. urban or rural, distributor or residential street).

If the route is assessed as suitable in its current condition according to the network requirements and design standards it can be included in the Existing Routes Map.

## Table Appendix B - Walking Route Audit Tool

Audit Categories	2 (Green)	1 (Amber)	0 (Red)	Comments
1. ATTRACTIVENESS - maintenance	Footways well maintained, with no significant issues noted.	Minor littering. Overgrown vegetation. Street furniture falling into mi-nor disrepair (for example, peeling paint).	Littering and/or dog mess prevalent. Seriously overgrown vegetation, including low branches. Street furniture falling into major disrepair.	
2. ATTRACTIVENESS - fear of crime	No evidence of vandalism with appropriate natural surveillance.	Minor vandalism. Lack of active frontage and natural surveillance (e.g. houses set back or back onto street).	Major or prevalent vandalism. Evidence of criminal/antisocial activity. Route is isolated, not subject to natural surveillance (including where sight lines are inadequate).	
3. ATTRACTIVENESS - traffic noise and pollution	Traffic noise and pollution do not affect the attractiveness	Levels of traffic noise and/or pollution could be improved	Severe traffic pollution and/or severe traffic noise	
4. ATTRACTIVENESS - other	Examples of 'other' attractiveness issues include: - Evidence that lighting is not present, or is deficient; - Temporary features affecting the attractiveness of routes (e.g. refuse sacks). - Excessive use of guardrail or bollards  Score 0-2 as appropriate			

Audit Categories	2 (Green)	1 (Amber)	0 (Red)	Comments
5. COMFORT - condition	Footways level and in good condition, with no trip hazards.	Some defects noted, typically isolated (such as trenching or patching) or minor (such as cracked, but level pavers). Defects unlikely to result in trips or difficulty for wheelchairs, prams etc. Some footway crossovers resulting in uneven surface.	- subsided or fretted pavement; or - significant uneven patching or trenching. Large number of footway crossovers resulting in uneven surface.	
6. COMFORT - footway width	Able to accommodate all users without 'give and take' between users or walking on roads. Footway widths generally in excess of 2m.	Footway widths of between approximately 1.5m and 2m. Occasional need for 'give and take' between users and walking on roads.	Footway widths of less than 1.5m (i.e. standard wheelchair width). Limited footway width requires users to 'give and take' frequently, walk on roads and/or results in crowding/delay.	
7. COMFORT - width on staggered crossings/ pedestrian islands/refuges	Able to accommodate all users without 'give and take' between users or walking on roads. Widths generally in excess of 2m to accommodate wheel-chair users.	Widths of between approximately 1.5m and 2m. Occasional need for 'give and take' between users and walking on roads.	Widths of less than 1.5m (i.e. standard wheelchair width). Limited width requires users to 'give and take' frequently, walk on roads and/or results in crowding/delay.	
8. COMFORT - footway parking	No instances of vehicles parking on footways noted. Clearance widths generally in excess of 2m between permanent obstructions.	Clearance widths between approximately 1.5m and 2m. Occasional need for 'give and take' between users and walking on roads due to footway parking. Footway parking causes some deviation from desire lines.	Clearance widths less than 1.5m. Footway parking requires users to 'give and take' frequently, walk on roads and/or results in crowding/delay. Footway parking causes significant deviation from desire lines.	

Audit Categories	2 (Green)	1 (Amber)	0 (Red)	Comments
9. COMFORT - gradient	There are no slopes on footway.	Slopes exist but gradients do not exceed 8 per cent (1 in 12).	Gradients exceed 8 per cent (1 in 12).	
10. COMFORT - other	<p>Examples of 'other' comfort issues include:</p> <ul style="list-style-type: none"> <li>- Temporary obstructions restricting clearance width for pedestrians (e.g. driveway gates opened into footway);</li> <li>- Barriers/gates restricting access; and</li> <li>- Bus shelters restricting clearance width.</li> <li>- Poorly drained footways resulting in noticeable ponding issues/slippery surfaces</li> </ul> <p>Score 0-2 as appropriate</p>			
11. DIRECTNESS - footway provision	Footways are provided to cater for pedestrian desire lines (e.g. adjacent to road).	Footway provision could be improved to better cater for pedestrian desire lines.	Footways are not provided to cater for pedestrian desire lines.	
12. DIRECTNESS - location of crossings in relation to desire lines	Crossings follow desire lines.	Crossings partially diverting pedestrians away from desire lines.	Crossings deviate significantly from desire lines.	
13. DIRECTNESS - gaps in traffic (where no controlled crossings present or if likely to cross outside of con-trolled crossing)	Crossing of road easy, direct, and comfortable and without delay (< 5s average).	Crossing of road direct, but associated with some delay (up to 15s average).	Crossing of road associated indirect, or associated with significant delay (>15s average).	

Audit Categories	2 (Green)	1 (Amber)	0 (Red)	Comments
14. DIRECTNESS - impact of controlled crossings on journey time	Crossings are single phase pelican/puffin or zebra crossings.	Crossings are staggered but do not add significantly to journey time. Unlikely to wait >5s in pedestrian island.	Staggered crossings add significantly to journey time. Likely to wait >10s in pedestrian is-land.	
15. DIRECTNESS - green man time	Green man time is of sufficient length to cross comfortably.	Pedestrians would benefit from extended green man time but current time unlikely to deter users.	Green man time would not give vulnerable users sufficient time to cross comfortably.	
16. DIRECTNESS - other	Examples of 'other' directness issues include: - Routes to/from bus stops not accommodated; - Steps restricting access for all users; - Confusing layout for pedestrians creating severance issues for users.  Score 0-2 as appropriate			
17. SAFETY - traffic volume	Traffic volume low, or pedestrians can keep distance from moderate traffic volumes.	Traffic volume moderate and pedestrians in close proximity.	High traffic volume, with pedestrians unable to keep their distance from traffic.	
18. SAFETY - traffic speed	Traffic speeds low, or pedestrians can keep distance from moderate traffic speeds.	Traffic speeds moderate and pedestrians in close proximity.	High traffic speeds, with pedestrians unable to keep their distance from traffic.	

Audit Categories	2 (Green)	1 (Amber)	0 (Red)	Comments
19. SAFETY - visibility	Good visibility for all users.	Visibility could be somewhat improved but unlikely to result in collisions.	Poor visibility, likely to result in collisions.	
20. COHERENCE - dropped kerbs and tactile paving	Adequate dropped kerb and tactile paving provision.	Dropped kerbs and tactile paving provided, albeit not to current standards.	Dropped kerbs and tactile paving absent or incorrect.	
COHERENCE	Signage - Note the presence and quality of route signage (no score is required for this factor)			



Llywodraeth Cymru  
Welsh Government

# Appendix C

## Cycle Route Audit Tool



# Cycle Route Audit Tool – Guidance notes

This tool has been developed to assist local authorities in the auditing of routes.

The tool can be used for both existing and proposed routes.

- On existing routes the current conditions should be audited.
- On proposed routes the proposed schemes should be audited.

## Scoring

The tool as shown in the table on p.394, requires the auditor to score the route against each of the factors using the following scale:

- 0 for poor provision,
- 1 for provision which is adequate but should be improved if possible
- 2 for good quality provision

Any route which scores less than 35 (out of a potential 50 points, ie a score of 70%) will require further improvement before it is included in the Existing or Integrated Network Maps. This threshold will be kept under review in the light of experience.

## Critical factors

Some of the criteria have been given a 'critical' rating.

Routes which fail to pass any of the critical factors require further development and should not be included on the Existing or Integrated Network Maps.

## Comments

As the scoring is sometimes qualitative the tool also allows the auditor to add comments explaining their score allocation.

For example where a route has scored 1 for Gradient, it may be useful to explain that although there is a steep uphill chapter there is a path which climbs the side of the valley in gentle steps, thereby allowing the cyclist to comfortably use the route.

The addition of text allows the audit scoring to be better understood when reviewed by other stakeholders.



## Actions

There is an additional column for Actions. This allows auditors to record any solutions to any of the issues identified on the route e.g. narrowing a junction mouth to reduce speeds or removing redundant street clutter along a chapter of the route to improve its attractiveness.

The assessment relies on an understanding of the route type (ie primary route, secondary route or local route) to be provided for as well as a full understanding of the existing traffic conditions (i.e. urban or rural, distributor or residential street).

If the route is assessed as suitable in its current condition according to the network requirements and design standards it can be included in the Existing Routes Map.

## Table Appendix C - Cycling Route Audit Tool

Key Requirement	Factor	Design Principle	Indicators	Critical	0 (Red)	1 (Amber)	2 (Green)	Score	Comments
Cohesion	Connections	Cyclists should be able to easily and safely join and navigate along different sections of the same route and between different routes in the network.	1. Ability to join/leave route safely and easily: consider left and right turns		Cyclists cannot connect to other routes without dismounting	Cyclists can connect to other routes with minimal disruption to their journey	Cyclists have dedicated connections to other routes provided, with no interruption to their journey		
	Continuity and Wayfinding	Routes should be complete with no gaps in provision. 'End of route' signs should not be installed - cyclists should be shown how the route continues. Cyclists should not be 'abandoned', particularly at junctions where provision may be required to ensure safe crossing movements.	2. Provision for cyclists throughout the whole length of the route		Cyclists are 'abandoned' at points along the route with no clear indication of how to continue their journey.	The route is made up of discrete sections, but cyclists can clearly understand how to navigate between them, including through junctions.	Cyclists are provided with a continuous route, including through junctions		
	Density of network	Cycle networks should provide a mesh (or grid) of routes across the town or city. The density of the network is the distance between the routes which make up the grid pattern. The ultimate aim should be a network with a mesh width of 250m.	3. Density of routes based on mesh width ie distances between primary and secondary routes within the network		Route contributes to a network density mesh width >1000	Route contributes to a network density mesh width 250 - 1000m	Route contributes to a network density mesh width <250m		

Key Requirement	Factor	Design Principle	Indicators	Critical	0 (Red)	1 (Amber)	2 (Green)	Score	Comments
Directness	Distance	Routes should follow the shortest option available and be as near to the 'as-the-crow-flies' distance as possible.	4. Deviation of route Deviation Factor is calculated by dividing the actual distance along the route by the straight line (crow-fly) distance, or shortest road alternative.		Deviation factor against straight line or shortest road alternative >1.4	Deviation factor against straight line or shortest road alternative 1.2 – 1.4	Deviation factor against straight line or shortest road alternative <1.2		
	Time: Frequency of required stops or give ways	The number of times a cyclist has to stop or loses right of way on a route should be minimised. This includes stopping and give ways at junctions or crossings, motorcycle barriers, pedestrian-only zones etc.	5. Stopping and give way frequency		The number of stops or give ways on the route is more than 4 per km	The number of stops or give ways on the route is between 2 and 4 per km	The number of stops or give ways on the route is less than 2 per km		
	Time: Delay at junctions	The length of delay caused by junctions should be minimised. This includes assessing impact of multiple or single stage crossings, signal timings, toucan crossings etc.	6. Delay at junctions		Delay for cyclists at junctions is greater than for motor vehicles	Delay for cyclists at junctions is similar to delay for motor vehicles	Delay is shorter than for motor vehicles or cyclists are not required to stop at junctions (eg bypass at signals)		

Key Requirement	Factor	Design Principle	Indicators	Critical	0 (Red)	1 (Amber)	2 (Green)	Score	Comments
Safety	Time: Delay on links	The length of delay caused by not being able to bypass slow moving traffic.	7. Ability to maintain own speed on links		Cyclists travel at speed of slowest vehicle (including a cycle) ahead	Cyclists can usually pass slow traffic and other cyclists	Cyclists can always choose an appropriate speed.		
	Gradients	Routes should avoid steep gradients where possible. Uphill sections increase time, effort and discomfort. Where these are encountered, routes should be planned to minimise climbing gradient and allow users to retain momentum gained on the descent.	8. Gradient		Route includes sections steeper than the gradients recommended in Figure 4.4	There are no sections of route steeper than the gradients recommended in Figure 4.4	There are no sections of route which steeper than 2%		
	Reduce/remove speed differences where cyclists are sharing the carriageway	Where cyclists and motor vehicles are sharing the carriageway, the key to reducing severity of collisions is reducing the speeds of motor vehicles so that they more closely match that of cyclists. This is particularly important at points where risk of collision is greater, such as at junctions.	9. Motor traffic speed on approach and through junctions where cyclists are sharing the carriageway through the junction	85th percentile > 37mph (60kph)	85th percentile >30mph	85th percentile 20mph-30mph	85th percentile <20mph		
			10. Motor traffic speed on sections of shared carriageway	85th percentile > 37mph (60kph)	85th percentile >30mph	85th percentile 20mph-30mph	85th percentile <20mph		

Key Requirement	Factor	Design Principle	Indicators	Critical	0 (Red)	1 (Amber)	2 (Green)	Score	Comments
	Avoid high motor traffic volumes where cyclists are sharing the carriageway	Cyclists should not be required to share the carriageway with high volumes of motor vehicles. This is particularly important at points where risk of collision is greater, such as at junctions.	11. Motor traffic volume on sections of shared carriageway, expressed as vehicles per peak hour	>10000 AADT, or >5% HGV	5000-10000 AADT and <2-5%HGV	2500-5000 and <2% HGV	0-2500 AADT		
	Risk of collision	Where speed differences and high motor vehicle flows cannot be reduced cyclists should be separated from traffic – see Table 6.2. This separation can be achieved at varying degrees through on-road cycle lanes, hybrid tracks and off-road provision. Such segregation should reduce the risk of collision from beside or behind the cyclist.	12. Segregation to reduce risk of collision alongside or from behind	Cyclists sharing carriageway - nearside lane in critical range between 3.2m and 3.9m wide and traffic volumes prevent motor vehicles moving easily into opposite lane to pass cyclists.	Cyclists in unrestricted traffic lanes outside critical range (3.2m to 3.9m) or in cycle lanes less than 1.8m wide.	Cyclists in cycle lanes at least 1.8m wide on carriageway; 85th percentile motor traffic speed max 30mph.	Cyclists on route away from motor traffic (off road provision) or in off-carriageway cycle track. Cyclists in hybrid/light segregated track: 85th percentile motor traffic speed max 30mph.		

Key Requirement	Factor	Design Principle	Indicators	Critical	0 (Red)	1 (Amber)	2 (Green)	Score	Comments
		A high proportion of collisions involving cyclists occur at junctions. Junctions there-fore need particular attention to reduce the risk of collision. Junction treatments include: Minor/side roads - cyclist priority and/or speed reduction across side roads Major roads - separation of cyclists from motor traffic through junctions.	13. Conflicting movements at junctions		Side road junctions frequent and/ or untreated. Major junctions, conflicting cycle/ motor traffic movements not separated	Side road junctions infrequent and with effective entry treatments. Major junctions, principal conflicting cycle/ motor traffic movements separated.	Side roads closed or treated to blend in with footway. Major junctions, all conflicting cycle/motor traffic streams separated.		
	Avoid complex design	Avoid complex designs which require users to process large amounts of information. Good network design should be self-explanatory and self-evident to all road users. All users should understand where they and other road users should be and what movements they might make.	14. Legible road markings and road layout		Faded, old, unclear, complex road markings/ unclear or unfamiliar road layout	Generally legible road markings and road layout but some elements could be improved	Clear, understandable, simple road markings and road layout		

Key Requirement	Factor	Design Principle	Indicators	Critical	0 (Red)	1 (Amber)	2 (Green)	Score	Comments
	Consider and reduce risk from kerbside activity	Routes should be assessed in terms of all multi-functional uses of a street including car parking, bus stops, parking, including collision with opened door.	15. Conflict with kerbside activity	Narrow cycle lanes <1.5m or less (including any buffer) alongside parking/loading	Significant conflict with kerbside activity (eg nearside cycle lane < 2m (including buffer) wide alongside kerbside parking)	Some conflict with kerbside activity - eg less frequent activity on nearside of cyclists, min 2m cycle lanes including buffer.	No/very limited conflict with kerbside activity or width of cycle lane including buffer exceeds 3m.		
	Reduce severity of collisions where they do occur	Wherever possible routes should include "evasion room" (such as grass verges) and avoid any unnecessary physical hazards such as guardrail, build outs, etc. to reduce the severity of a collision should it occur.	16. Evasion room and unnecessary hazards		Cyclists at risk of being trapped by physical hazards along more than half of the route.	The number of physical hazards could be further reduced	The route includes evasion room and avoids any physical hazards.		
Comfort	Surface quality	Density of defects including non cycle friendly ironworks, raised/sunken covers/gullies, potholes, poor quality carriageway paint (eg from previous cycle lane)	17. Major and minor defects		Numerous minor defects or any number of major defects	Minor and occasional defects	Smooth high grip surface		

Key Requirement	Factor	Design Principle	Indicators	Critical	0 (Red)	1 (Amber)	2 (Green)	Score	Comments
		Pavement or carriageway construction providing smooth and level surface	18. Surface type		Any bumpy, unbound, slippery, and potentially hazardous surface.	Hand-laid materials, concrete pavements with frequent joints.	Machine laid smooth and non-slip surface - eg Thin Surfacing, or firm and closely-jointed blocks undisturbed by turning heavy vehicles.		
	Effective width without conflict	Cyclists should be able to comfortably cycle without risk of conflict with other users both on and off road.	19. Desirable minimum widths according to volume of cyclists and route type (where cyclists are separated from motor vehicles).		More than 25% of the route includes cycle provision with widths which are no more than 25% below desirable minimum values.	No more than 25% of the route includes cycle provision with widths which are no more than 25% below desirable minimum	Recommended widths are maintained throughout whole route		
	Wayfinding	Non-local cyclists should be able to navigate the routes without the need to refer to maps.	20. Signing		Route signing is poor with signs missing at key decision points.	Gaps identified in route signing which could be improved	Route is well signed with signs located at all decision points and junctions		



Key Requirement	Factor	Design Principle	Indicators	Critical	0 (Red)	1 (Amber)	2 (Green)	Score	Comments
Attractiveness	Social safety and perceived vulnerability of user	Routes should be appealing and be perceived as safe and usable. Well used, well maintained, lit, overlooked routes are more attractive and therefore more likely to be used.	21. Lighting		Most or all of route is unlit	Short and infrequent unlit/poorly lit sections	Route is lit to highway standards throughout		
			22. Isolation		Route is generally away from activity	Route is mainly overlooked and is not far from activity throughout its length	Route is overlooked throughout its length		
	Impact on pedestrians, including people with disabilities	Introduction of dedicated on-road cycle provision can enable people to cycle on-road rather than using footways which are not suitable for shared use. Introducing cycling onto well-used footpaths may reduce the quality of provision for both users, particularly if the shared use path does not meet recommended widths.	23. Impact on pedestrians, Pedestrian Comfort Level based on Pedestrian Comfort guide for London (Section 4.7)		Route impacts negatively on pedestrian provision, Pedestrian Comfort is at Level C or below.	No impact on pedestrian provision or Pedestrian Comfort Level remains at B or above.	Pedestrian provision enhanced by cycling provision, or Pedestrian Comfort Level remains at A		

Key Requirement	Factor	Design Principle	Indicators	Critical	0 (Red)	1 (Amber)	2 (Green)	Score	Comments
	Minimise street clutter	Signage required to support scheme layout	24. Signs informative and consistent but not overbearing or of inappropriate size		Large number of signs needed, difficult to follow and/or leading to clutter	Moderate amount of signage particularly around junctions.	Signage for wayfinding purposes only and not causing additional obstruction.		
	Secure cycle parking	Ease of access to secure cycle parking within businesses and on street	25. Evidence of bicycles parked to street furniture or cycle stands		No additional cycle parking provided or inadequate provision in insecure non-overlooked areas	Some secure cycle parking provided but not enough to meet demand	Secure cycle parking provided, sufficient to meet demand		
								Audit Score Total	



Llywodraeth Cymru  
Welsh Government

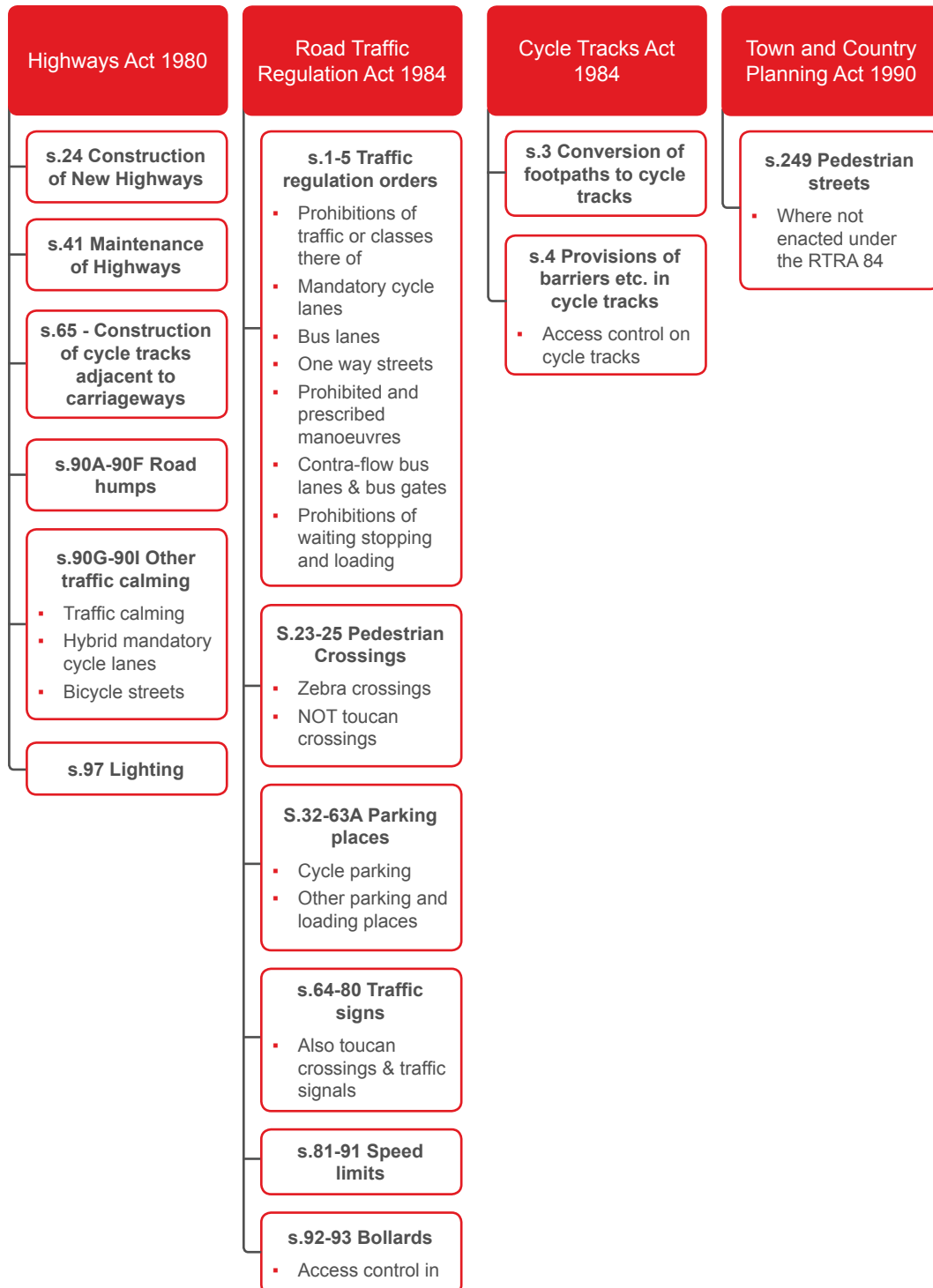
# Appendix D

## Legal Procedures



## Introduction

The diagram below sets out the main legal frameworks for the construction and maintenance of active travel routes and facilities. This appendix sets these out in more detail.



## Highways Act 1980

### Section 65 (Construction of cycle tracks adjacent to carriageways)

empowers highway authorities to provide cycle tracks within or next to highways including a carriageway (i.e. a street). This is not suitable for footpaths (i.e. where the only right of way across the entire width of the highway is by foot). There are no statutory requirements regarding the exercise of this power, although there needs to be evidence that the Highway Authority has exercised this power, particularly given such schemes may be contentious. The erection of the appropriate traffic signing will perform this role to an extent, though it is recommended that any conversion is formally made by a resolution of the relevant council committee, following consultation and engagement with stakeholders (Section 2.3).

Where a cycle track is proposed adjacent to a highway, but outside its adopted limits, this can be achieved by constructing a cycle track under section 65(1) of the Highways Act as a permitted development under Part 13 of Schedule 2 of the Town and Country Planning (General Permitted Development) Order 1995 (HMSO, 1995).

**Sections 90A-90F (Road humps)** allows Highway Authorities to construct road humps. Their design and installation is regulated by the Highways (Road Humps) Regulations 1999 (HMSO, 1999b). Advice relating to good practice and legal requirements with respect to de-sign can be found in Section 4 of LTN 1/07 Traffic Calming (Department for Transport, 2007a).

Section 90C (1) of the Highways Act 1980 requires that the Chief Officer of Police is consulted before road humps are installed. Sections 90C (2)&(5) of the same Act require authorities carry out the following procedure before installing road humps:

- Notices should be placed in local press and on-street, detailing each individual road hump proposed and inviting objections before a stated deadline not less than 21 days after the publication of proposals
- Any objections received should be considered by the Highway Authority. Typically objections will be considered by the relevant committee of the Council



Regulation 3 of the Highways (Road Humps) Regulations 1999 requires that the following bodies are consulted in addition to those above:

- The Chief Officer of the fire brigade
- The Chief Officer of any body providing ambulance services
- Any organisations appearing to the authority to represent persons who use the highway to which the proposal relates, or to represent persons who are otherwise likely to be affected by the road hump

**Sections 90G-90I (Other traffic calming)** allows highway authorities to construct other traffic calming measures. These measures are regulated by the Highways (Traffic Calming) Regulations 1999 (HMSO, 1999a), which permit the following measures:

- Build-outs
- Chicanes
- Gateways
- Islands
- Over-run areas
- Pinch points
- Rumble devices
- Combinations of the above

The regulations impose limits on the design of over-run areas and rumble devices. Section 5 of LTN 1/07 Traffic Calming (Department for Transport, 2007a) offers design advice – additional care should be taken to ensure such features do not pose a hazard to cyclists.

**Sections 97 (Lighting)** empowers highway authorities to provide lighting on highways, including cycle tracks. There is no prescribed procedure for providing such lighting.

### **Road Traffic Regulation Act 1984**

**Sections 1-5 (Traffic regulation orders)** empower highway authorities to make Traffic Regulation Orders (TROs) to regulate road traffic. TROs are usually required where any road traffic activity in any part of the highway is to be prohibited or restricted for any user, over and above what is prohibited by other legislation.



In terms of cycling infrastructure, the following will require the implementation or amendment of TROs:

- Pedestrianised streets
- Bus lanes (with-flow and contraflow)
- One way streets (including with contra-flow cycling)
- Mandatory cycle lanes
- Prohibited & prescribed manoeuvres
- Exemptions from existing restrictions

TROs will also be required for other traffic restrictions introduced to facilitate cycling, including road closures and prohibitions of waiting and/or loading.

TROs can be made for a variety of reasons, prescribed under Section 1 of the 1984 Act. With regard to cycling infrastructure, it will typically be appropriate to state that the order is made for the purposes of facilitating the passage of pedal cycles along the affected street(s).

Where the cycling infrastructure is simply an exemption from a TRO applying to other traffic, the exemption for cycles **must** be written into the TRO. This means a new TRO will be required where it is proposed to exempt cycles from an existing restriction. Section 2 of the Act allows for such exemptions.

Care needs to be taken in the drafting of TROs to ensure the provisions match the definitions and signing and lining used. For example, the provisions for a contra-flow cycle lane will need to be more detailed than for where cycles are simply exempted from a one way street as, for instance, motor vehicles need prohibiting from entering a mandatory contra-flow cycle lane.

There are restrictions on TROs, although these will not generally be relevant to cycling infra-structure. One exception concerns pedestrianised streets. Where it is required to deny access to adjacent streets for any class of vehicle (cycles included) to adjacent premises for greater than 8 hours in any 24, it will be necessary to either seek the consent of the Welsh Government (this is only possible in certain circumstances), or make an order under the Town and Country Planning Act .

Speed limits, parking places and cycle tracks should not be made by Traffic Regulation Order (i.e. Orders made under Section 1 of the Road Traffic Regulation Act). These are made using different mechanisms:

- Speed limit orders are made under sections 81-91 of the Road Traffic Regulation Act
- Parking places are designated under sections 32-63A of the Road Traffic Regulation Act
- Cycle tracks in highways incorporating a carriageway are constructed under section 65 of the Highways Act 1980
- Conversion of footpaths away from highways incorporating a carriageway is made under Section 3 of the Cycle Tracks Act 1984; and,
- New cycle tracks outside of the highway are made under the Highways Act and planning legislation – advice of a planning officer should be sought in this instance.

**Procedure for TROs** is governed by the Local Authorities (Traffic Orders) (England and Wales) (Procedure) Regulations 1996 (HMSO, 1996). This is summarised in the document Traffic Regulation Orders – Your Questions Answered (Department for Transport, 2007c), and described in greater detail in Annex F of Operational Guidance to Local Authorities: Parking Policy and Enforcement (Department for Transport, 2008e).

**Sections 23-25 (Pedestrian crossings)** empower highway authorities to provide pedestrian crossings. These are prescribed by the Zebra, Pelican and Puffin Pedestrian Crossings Regulations 1997 (HMSO, 1997). Where it is proposed to install, alter or remove a pedestrian crossing, the traffic authority is required to:

- Consult the Chief Officer of Police
- Give notice to the public of the proposals
- Inform the Secretary of State in writing

There is no requirement in legislation for the Council to consider objections to pedestrian crossings.

Toucan crossings and signal-controlled crossings at junctions are not prescribed under this Section of the Act, but under Sections 64 to 80 (traffic signs).



**Sections 32-63A (Parking places)** empower traffic authorities to designate parking places. Orders are made under Sections 32 (off-street parking) or 45 (on-street parking) of the Act where a parking place is to be designated, including cycle parking places. Section 63 allows for the provision of stands or other devices to be provided for the safe keeping of cycles at designated parking places.

Parking place orders are made for the relief or prevention of traffic congestion – in the case of cycling parking places, this will be by encouraging modal shift onto pedal cycles. Cycle parking places can also relieve congestion on footways where cycles may be left haphazardly in the absence of proper facilities.

These powers are also used to provide limited waiting, permit parking and pay and display parking. The procedure is as for traffic regulation orders.

**Sections 64-80 (Traffic signs)** empower traffic authorities to provide traffic signs and road markings. Traffic signals are also prescribed under this mechanism. No specific procedure is prescribed for the erection of signs generally.

All traffic signs must conform to regulations or special authorisations issued by the Secretary of State or the Welsh Ministers – usually these will be the Traffic Signs Regulations and General Directions (HMSO). The requirement for signs to be prescribed in this way applies to ‘any length of highway or any other road to which the public has access, including bridges over which a road passes’ (HMSO, 1984a). It should be noted that ‘highway’ includes foot-paths, bridleways and cycle tracks

In Wales, the Traffic Signs (Welsh and English Language Provisions) Regulations and General Directions 1985 also apply (HMSO, 1985). These give requirements and provide the necessary diagrams regarding bilingual English and Welsh traffic signs.

The Regulations require TROs or other enactments to be in place where certain signs or markings are provided.

**Sections 81-91 (Speed limits)** concern speed limits. Guidance can be found in Setting Local Speed Limits in Wales (Welsh Government, 2009) Section 4 deals with the legislative framework. Procedure is as for traffic regulation orders.

**Sections 92 & 93 (Bollards)** authorise highway authorities to provide bollards or other obstructions to enforce a traffic regulation order. No additional process is required above and beyond that necessary for a traffic regulation order.

## **Cycle Tracks Act 1984**

**Section 3 (conversion of footpaths to cycle tracks)** allows highway authorities to convert footpaths (i.e. highways with right of way by foot only) to cycle tracks. The powers under this Act are rarely used, however, because when objections are made the process can become very extended.

Where the footpath crosses agricultural land, Section 3(2) requires the written consent of anyone with a legal interest in the land is obtained before the cycle track order can be made.

The procedure for making a cycle track order is governed by the Cycle Tracks Regulations 1984 (HMSO, 1984c). Before making a cycle track order, the authority must consult:

- One or more organisations representing persons using the footpath, or are likely to be affected by the proposed order, unless it appears to the authority that no such organisations exist
- Any community council within whose area the footpath lies
- Those statutory undertakers whose operational land is crossed by the footpath
- The Chief Officer of Police

Upon making the Order, notices should be placed in local press, at each end of the affected footpath and on any public notice boards in their locality, detailing the proposals and inviting objections before a stated deadline not less than 28 days after the publication of proposals, and send this notice to all consultees.

If no objections are received, the authority can confirm the Order itself. If objections are received, application must be made to the Welsh Ministers to confirm the Order. A public inquiry will be conducted, and following that the Welsh Ministers will decide whether to confirm the Order (as made or amended), or to reject the application.

Legal and physical works to accommodate the cycle track are a permitted development under Section 3 (Part 10) of the Cycle Track Act 1984, so planning consent is not required. This also applies when providing a metalled way for cyclists where none exists presently.

Conversion of a footpath to restricted by-way can be a less onerous means of permitting cycling than that provided by the Cycle Tracks Act.

**Section 4 (provision of barriers in cycle tracks etc.)** allows the highway authority to provide barriers or other features to safeguard users of the cycle track (whether adjacent to a carriageway or otherwise), and to segregate foot and cycle traffic. There are no procedural requirements for the installation of such features.

### **Town and Country Planning Act 1990**

Provisions within the Town and Country Planning Act 1990 (HMSO, 1990) and the Highways Act 1980 (HMSO, 1980) will apply where it is proposed to provide a cycle route where no right-of-way or physical path exists at present. In these instances, legal and planning advice should be sought.

**Section 249** of the Town and Country Planning Act provides a means of providing pedestrianised streets by extinguishing vehicular rights over highways. This can be a useful mechanism where the provisions of the Road Traffic Regulation Act are not robust enough for the desired level of restriction. Such Orders can only be made, altered or revoked by the Secretary of State – this includes any amendments to existing Orders that may be necessary to permit cycling at any time of the day.

Where S.249 Orders are proposed, or are existing, and are proposed to be amended to accommodate cycling, planning and legal advice should be sought.

### **Bridleways and Restricted Byways**

The legislative measures outlined above do not allow for the use of horses on cycle routes away from roads, or for the use of cycles on existing bridleways.

Section 30 of the Countryside Act 1968 (HMSO, 1968) permits cyclists to use bridleways, so it is not necessary to change the status of a bridleway to allow cycling. However, there are a number of issues where cycle routes are to follow bridleways:

- Section 30(3) of the Countryside Act 1968 specifically does not obligate the highway authority or any other responsible party to maintain bridleways to a standard able to accommodate cycling, or to do anything to facilitate cycling along the route. This risks bridleway sections of cycle route not being maintained sufficiently for cycling
- Cycle route signs are unlikely to be appropriate on bridleways and regulatory signs indicating a cycle track cannot be lawfully erected on bridleways. Providing route continuity along a bridleway section may therefore be difficult

On key cycle routes, it may be appropriate to give cyclists a greater claim to the facility than can be provided with bridleway status, in which case the bridleway can be converted to a restricted byway under section 26 of the Highways Act 1980 (HMSO, 1980).

The procedure for the conversion of a footpath or bridleway to restricted byway under Section 26 of the Highways Act 1980 is governed by the Public Path Orders Regulations 1993 (HMSO, 1993) and is described in A Guide to Definitive Maps and Changes to Public Rights of Way (Countryside Council for Wales, 2008).

Where the use of bridleways or restricted byways is proposed, care should be taken to ensure that facilities for equestrians are maintained and where possible extended into the countryside.

### **Experimental Schemes**

Where traffic regulation orders, speed limit orders or parking place orders are proposed, but prove to be controversial, it is possible to install the scheme experimentally before considering objections, so as to evaluate it.

This power is provided by Sections 9-11 of the Road Traffic Regulation Act 1984 (HMSO, 1984a). The procedure is described in Annex F of Operational Guidance to Local Authorities: Parking Policy and Enforcement (Department for Transport, 2008e), and can be summarised as follows:

- Notices should be placed in local press and on street, detailing the proposals, as for an ordinary TRO, at least 7 days before the Order is made
- The experimental order can be left in place for up to 18 months, during which people may lodge objections
- After a maximum of 18 months, any objections received should be considered by the Highway Authority, after which the Council may (subject to consideration of those objections) make the Order permanent, or let the Order lapse

This procedure can be used to alleviate public concerns by demonstrating the actual impact of the scheme, rather than simply relying upon expectation and speculation. However, it may also be interpreted as forcing proposals through without regard for public concerns, so this procedure should be used carefully. Experimental schemes should be carefully monitored so that their real impact can be reported on and amendments can be considered to mitigate for any issues observed.

## Equality Act 2010 - Equality Impact Assessments

All public bodies under Section 149 of the Equalities Act 2010 have a duty to promote and advance equality with specific reference in this case to highways functions; and record their actions within an Equality Impact Assessment (EqIA) to illustrate due considerations and mitigations.

An Equality Impact Assessment (EqIA) provides a key part of the process required when developing, reviewing or changing any initiative (i.e. service, policy, strategy, function, procedure, project etc). The resulting assessment is part of the work required on any initiative and provides some of the evidence base for what is being undertaken and the outcomes to be achieved.

They are a legal requirement under equalities legislation, and have been in place since 2000; reinforcing all public bodies' legislative duty to:

- Eliminate discrimination, harassment and victimisation
- Advance equality of opportunity between different groups
- Foster good relations between different groups

As well as being a legal requirement, Equality Impact Assessment (EqIA) are an effective way of identifying the needs of the community.

The potential impact on all groups and individuals covered by the Equality Act 2010 must be considered when authorities are planning, revising or considering reducing / terminating service, policy, function, strategy or project.

The trigger points for screening for an EqIA are:

- planning a new initiative (i.e. service, policy, strategy, function, procedure, project)
- making any moderate or significant changes to an initiative (including relocation)

**Carrying out and EqIA:** The Equality Impact Assessment should be taken into account in the early planning stages in order to ensure that any potential risks or issues relating to equality are identified as soon as possible.

Failing to pay due regard to equality and diversity when planning, amending or terminating an initiative can lead to a great deal of wasted time, effort and resources, not to mention prosecution if the outcome is proven to be unlawful.

When implementing an Equality Impact Assessment, some of the following questions should be considered. This list is not exhaustive but is intended to assist authorities when considering how the policy, strategy, project or function could impact on any particular group.

- What are you trying to achieve through the policy, strategy, project, procedure, service or function, and why?
- Who is intended to benefit from the policy, strategy, project, procedure, service or function, and how?
- Who will have responsibility for implementing the policy, strategy, project, procedure, service or function and how will this be done?
- Have you considered the appropriate terminology of the policy, strategy, project, procedure, service or function? Is reference to equalities explicitly?
- Does the policy, strategy, project, procedure, service or function comply with the Welsh Language Act 1993 and local authorities' Welsh Language Schemes?
- Will the policy, strategy, project, procedure, service or function be applicable to people of all ages, including younger and older people?
- Have you considered the diverse needs of disabled people with physical, sensory and mental impairments?
- Have you considered the diverse needs of those with other protected characteristics?





Llywodraeth Cymru  
Welsh Government

# Design Guidance

## Active Travel (Wales) Act 2013

December 2014